

FORCE®

AUTO & SPECIAL TOOLS *V. four*

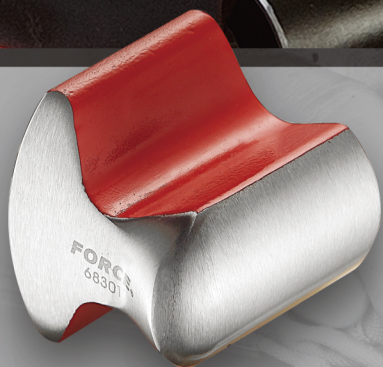

Power you on

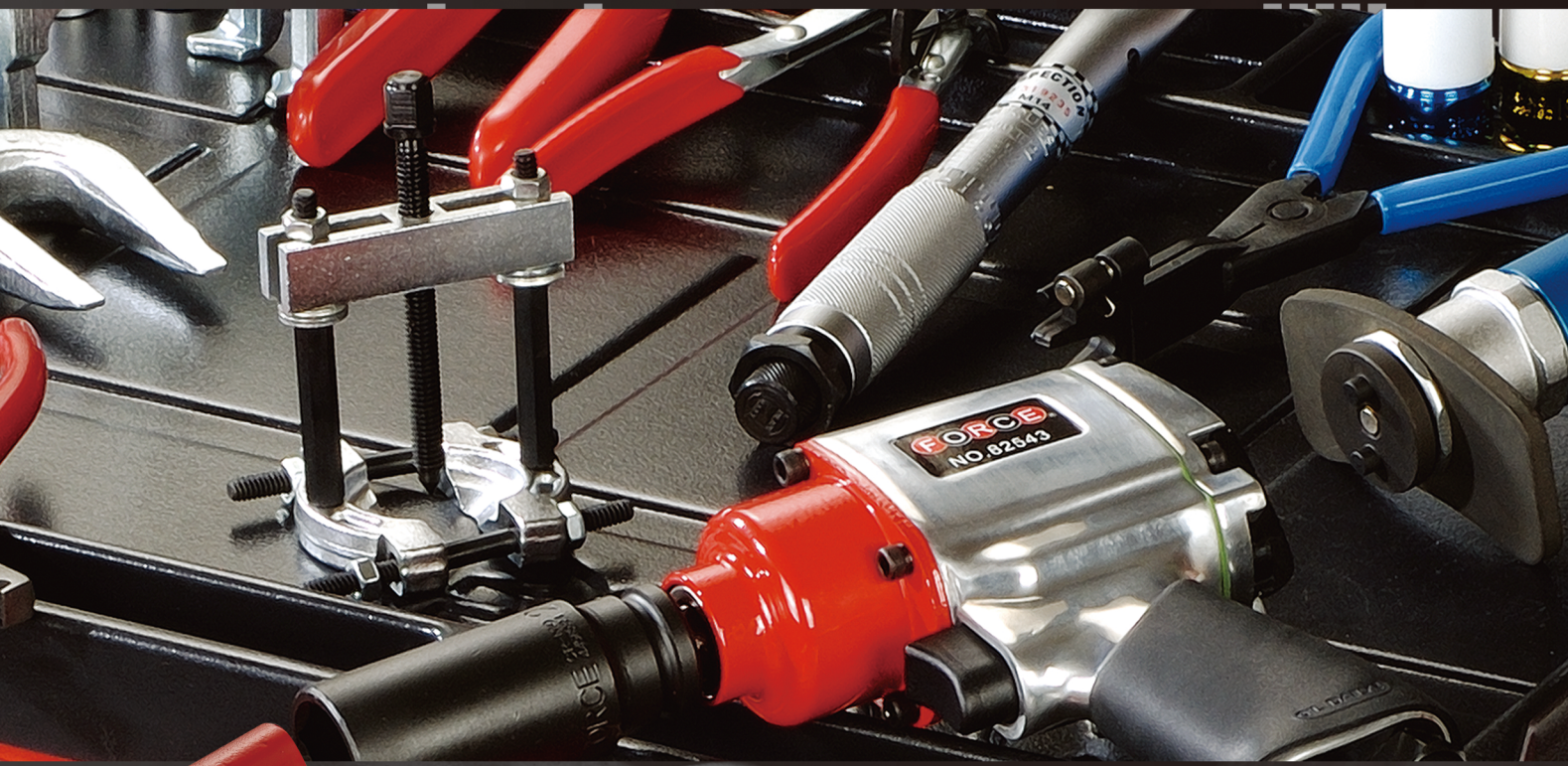

CERTIFICATE

**Management system as per
ISO 9001: 2008**

In accordance with TÜV NORD CERT procedures, it is hereby certified that
SHYANG YUN TOOLS CO., LTD.

No. 161, Sitou Rd., Shengang District,
Taichung City 42953, Taiwan, Republic of China



applies a management system in line with the above standard for the following scope

**Design, Development and Manufacturing of Hand Tools, Auto
Tools and Pneumatic Tools**

Certificate Registration No. 44 100 072011
Audit Report No. TW-1760/2016

Valid until 2018-09-14
Issue Date 2016-01-19
Initial Certification 2007-01-15



Certification Body
at TÜV ASIA PACIFIC LIMITED Taiwan Branch

TÜV ASIA PACIFIC LIMITED
Taiwan Branch
Room A1, 9F, No.333, Sec.2,
Tun Hua S. Rd.,
Taipei 10669 Taiwan, R.O.C.

This certification was conducted in accordance with the TÜV ASIA PACIFIC LIMITED Taiwan Branch auditing and certification procedures based on TÜV NORD CERT auditing and certification procedures and is subject to regular surveillance audits.

www.tuvnord.com.tw



RDC, TW1760, RC

General Information

This catalogue replaces all previous editions. All rights reserved in all countries. Reprinting and excerpts require a prior permission in writing by Shyang Yun Tools Co., Ltd.

The photographs and the technical details are of the articles at present offered.

Since we are constantly updating and improving our products to meet user needs and technological developments, we reserve the right to make modifications and changes with regard to photographs, specifications, sizes, packing, weights and performance without notice.

There is no liability for printing errors and correction or replacement supplies with regard to products already delivered.

Cancellations of all models and sets may be made at any time without there being any grounds for legal claim.

FORCE is a registered trademark.

All other trademarks mentioned in this document or website are the property of their respective owners.

The use of the word partner does not imply a partnership relationship between Shyang Yun Tools Co., Ltd. and any other company.

© Copyright by Shyang Yun Tools Co., Ltd.
All rights reserved.

FORCE[®] INDEX

Anything you need for tools.

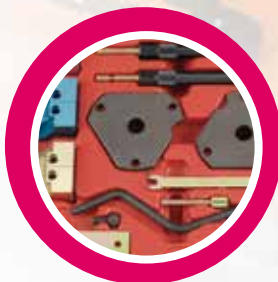

P. 1-1~1-133

ENGINE



P. 5-1~5-31

AUTO BODY



P. 2-1~2-26

**ELECTRICAL/
CABLE**



P. 6-1~6-18

MOTORCYCLE

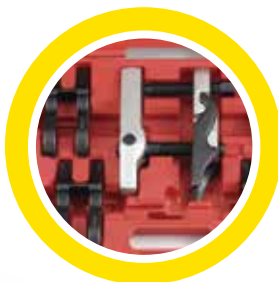

P. 3-1~3-69

**BRAKE/
TRANSMISSION**



P. 7-1~7-34

**PULLER/
TORQUE WRENCH**



P. 4-1~4-28

TRUCK



P. 8-1~8-70

GENERAL

1. ENGINE



Ignition system tool
Page 1-1 ~ 1-9



Clutch alignment tool
Page 1-49 ~ 1-50



Tester tool
Page 1-65 ~ 1-74



Oil filter / Drain plug / Funnel
Page 1-97 ~ 1-112



Engine support / Crane tool
Page 1-127 ~ 128



Timing tool
Page 1-9 ~ 1-41



Engine belt tool
Page 1-51 ~ 1-55



Diesel engine tool
Page 1-74 ~ 1-84



Fuel tool
Page 1-113 ~ 1-121



A/C tool
Page 1-129 ~ 1-133



Pulley hold tool
Page 1-41 ~ 1-45



Hose tool
Page 1-55 ~ 1-61



Engine valve tool
Page 1-84 ~ 1-91



Oxygen sensor / Air bag tool
Page 1-122 ~ 1-123



Pulley puller tool
Page 1-46 ~ 1-48



Cooling system tool
Page 1-61 ~ 1-65

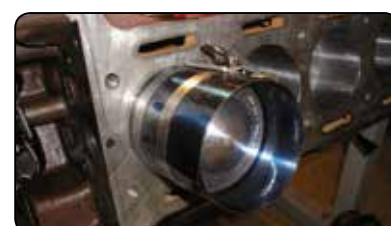

Cylinder / Piston tool
Page 1-91 ~ 1-97



Seal tool
Page 1-124 ~ 1-126



13pc Spark plug maintenance kit

K913G5



Content: 3/8"DR.

- 8323 18...24 2-Torque adapter
18Nm; 24Nm
- 802318 1-Flexible ratchet handle
- 807316M...20.6M 2-Magnetic spark plug socket
16; 20.6 mm
- 8043150 1-Extension 150mm-6"
- 61802 1-26 sizes Feeler gauges (SAE & Metric)
- 63001 1-Spark plug hole thread chaser
- 63004 1-14mm Spark plug hole rethreader
- 9U3001 1-Brass & Nylon scrape brushes
- 9G3101 1-Calibrated ignition tester (HEI system)
- 9G3102 1-Calibrated ignition tester (Standard system)
- 9G0107 1-Spark plug boot pliers

6/16.3/17.3/1.5' 2720g

10pc 3/8"DR. Spark plug socket set

T31010



NEW

Part no.	Contents: 3/8"DR.
80531E	1-Universal joint (extension type)
832 318...324	2-Torque adapter 18Nm; 24Nm
8073 14M...20.6M	4-Magnetic spark plug socket 14; 16; 18; 20.6mm
8073250 14M...20.6M	3-Magnetic spark plug socket (250mmL) 14; 16; 20.6mm

6/13.7/14.7/0.65' 2278g

2pc Torque adapter (spark plug special)

K3021



Content: 3/8"DR.

- 832 318...324 2-Torque adapter 18Nm; 24Nm

24/12.0/13.0/0.8' 500g

3/8" DR. Preset torques wrench

647...P



Part no.	Capacity Nm	l mm	g
647318P	18	245	1500
647324P	24	245	1500

56pc Spark plug rethread kit

956G1



- Completed set for repairing spark plug thread - M10, M12, and M14
- Contents: Screw-coil: 15PC M10-1.0 X 3/8
15PC M12-1.25 X 3/4
15PC M14-1.25 X 7/16
- Tap: M10-1.0, M12-1.25, M14-1.25
- Coil installation shank (length: 90mm): M10-1.0, M12-1.25, M14-1.25
- Coil shielding collar (internal thread): M10-1.0, M12-1.25, M14-1.25
- 1PC Main tool
- 1PC Hex key

10/12.8/13.8/2.3' 1234.5g

Spark plug hole rethreader

63001 / 63002 / 63003

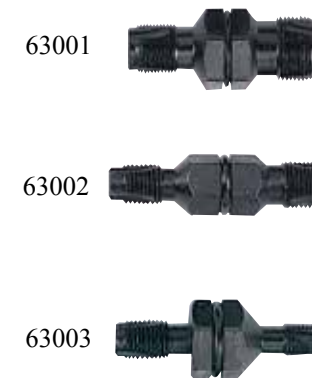

- Applying company with 13/16" standard deep socket.



Part no.	Thread mm	packing	g
63001	14&18	100/15.0/16.0/1.5'	150
63002	12&14	100/13.5/14.5/1.5'	135
63003	10&12	100/10.0/11.0/1'	100

14mm Spark plug hole rethreader

63004



- Use it to clean and restore the threads on 14mm spark plug hole prior to installation of spark plug.
- Features extra-long neck for access to recessed spark plug cavities.
- Apply it accompanied with 3/8" drive or 5/8" standard socket.

144/9/10/1.2' 58g

■ 5pc Spark plug rethreader set

64101



- Repairing stripped or damaged threads in aluminum cylinder heads.
- Solid steel inserts replace damaged threads.

Content:

1pc 14mm Spark plug rethreader
4pc inserts 3/8"; 7/16"; 1/2"; 3/4" long

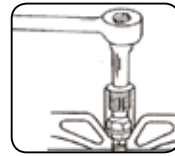
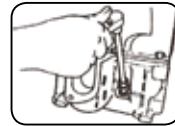

72/10.4/11.4/0.9' 144g

■ 3/8" DR. Universal spark plug socket (ball type)

8073...B



Part no.	Socket	l mm	g	pc/box
807316B	16mm	95	114	10
807320.6B	20.6mm	95	150	10

■ 3/8" DR. Universal magnetic spark plug socket (ball type)

8073...BM



Part no.	Socket	l mm	g	pc/box
807314BM	14mm	95	90	10
807316BM	16mm	95	118	10
807320.6BM	20.6mm	95	154	10

■ 3/8" DR. Universal spark plug socket (joint type)

8073...U



Part no.	Socket	l mm	g	pc/box
807316U	16mm	95	114	10
807320.6U	20.6mm	95	150	10

■ 1/2" DR. Universal spark plug socket (joint type)

8074...U



Part no.	Socket	l mm	g	pc/box
807416U	16mm	95	102	10
807420.6U	20.6mm	95	164	10

■ 3/8" DR. Universal magnetic spark plug socket (joint type)

8073...UM



Part no.	Socket	l mm	g	pc/box
807314UM	14mm	95	88	10
807316UM	16mm	95	114	10
807320.6UM	20.6mm	95	150	10

■ 1/2" DR. Universal magnetic spark plug socket (joint type)

8074...UM



Part no.	Socket	l mm	g	pc/box
807416UM	16mm	100	102	10
807420.6UM	20.6mm	100	164	10

■ 3/8" DR. Universal spark T wrench(ball type)

8073...B



Part no.	Socket	l mm	g	pc/box
807330016B	16mm	300	354	40
807330020.6B	20.6mm	300	392	40
807350016B	16mm	500	552	40
807350020.6B	20.6mm	500	590	40

■ 3/8" DR. Universal magnetic spark T wrench (ball type)

8073...BM



Part no.	Socket	l mm	g	pc/box
807330016BM	16mm	300	354	40
807330020.6BM	20.6mm	300	392	40
807350016BM	16mm	500	554	40
807350020.6BM	20.6mm	500	592	40

■ 3/8" DR. Universal spark T wrench (joint type)

8073...U



Part no.	Socket	l mm	g	pc/box
807330016U	16mm	300	354	40
807330020.6U	20.6mm	300	392	40
807350016U	16mm	500	552	40
807350020.6U	20.6mm	500	590	40
807380016U	16mm	800	850	15
807380020.6U	20.6mm	800	888	15

■ 1/2" DR. Universal spark T wrench (joint type)

8074...U



Part no.	Socket	l mm	g	pc/box
807430016U	16mm	300	646	30
807430020.6U	20.6mm	300	684	30
807450016U	16mm	500	936	30
807450020.6U	20.6mm	500	974	30
807480016U	16mm	800	1150	15
807480020.6U	20.6mm	800	1188	15

■ 3/8" DR. Universal magnetic spark T wrench (joint type)

8073...UM



Part no.	Socket	l mm	g	pc/box
807330016UM	16mm	300	356	40
807330020.6UM	20.6mm	300	394	40
807350016UM	16mm	500	554	40
807350020.6UM	20.6mm	500	592	40
807380016UM	16mm	800	852	15
807380020.6UM	20.6mm	800	890	15

■ 1/2" DR. Universal magnetic spark T wrench (joint type)

8074...UM



Part no.	Socket	l mm	g	pc/box
807430016UM	16mm	300	356	30
807430020.6UM	20.6mm	300	394	30
807450016UM	16mm	500	554	20
807450020.6UM	20.6mm	500	592	20
807480016UM	16mm	800	852	15
807480020.6UM	20.6mm	800	890	15

■ 3/8" DR. Magnetic long spark plug socket

8073250...M



Part no.	Socket	l mm	g	pc/box
807325014M	14mm	250	316	10
807325016M	16mm	250	344	10
807325020.6M	20.6mm	250	440	10

■ 3/8"DR. Spark plug socket

8073



Part no.	Socket	l mm	g	pc/box
807314	14mm	65	65	10
807316	16mm	63	96	10
807318	18mm	63	125	10
807320.6	20.6mm	63	150	10

■ 1/2" DR. Spark plug socket

8074



Part no.	Socket	l mm	g	pc/box
807414	14mm	65	65	10
807416	16mm	65	92	10
807418	18mm	65	133	10
807420.6	20.6mm	65	156	10

■ **3/8" DR. Magnetic spark plug socket**

8073...M



Part no.	Socket	l	g	pc/box
807314M	14mm	70	74	10
807316M	16mm	70	80	10
807318M	18mm	70	122	10
807320.6M	20.6mm	70	151	10

■ **1/2" DR. Magnetic spark plug socket**

8074...M



Part no.	Socket	l	g	pc/box
807414M	14mm	70	72	10
807416M	16mm	70	86	10
807418M	18mm	70	146	10
807420.6M	20.6mm	70	148	10

■ **3/8" DR. Magnetic spark plug socket (Thin wall)**

8073...MTH



Part no.	Size	Length	Diameter	Weight	pc/box
	mm	mm	mm	g	
807314MTH	14	70	18	74	10
807316MTH	16	70	19.9	80	10
807318MTH	18	70	23	122	10
807320.6MTH	20.6	70	26	151	10

■ **Spark plug gauge**

63008



- This popular solid steel spark plug gauge is designed with a tapered edge for gauging spark plugs and with a flanged hole to adjust the side wire of plugs without pressuring center electrode. Marked in standard and metric sizes.
- Size range: 0.020" to 0.100" (0.5mm to 2.53mm)



288/5.5/6.5/0.5' 26g

■ **Spark plug terminal pliers**

9G0101



- Safely remove spark plug cables and prevent cable damage.
- Handles and jaws of the pliers are coated with a heavy-duty plastic for a sure grip.



96/28.8/29.8/2.2' 300g

■ **4pc VW, AUDI Ignition coils puller set**

904T5

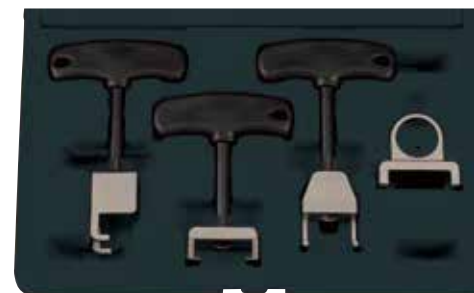

- Use for VW BORA, GOLF, NEW BEETLE, PASSAT, POLO, TOURAN 1.4/1.6L, LUPU 4-ZYL. FSI, PHAETON AND T4, BBY. BKY1.4.
- Use for VW BORA, GOLF, PASSAT, SHARAN, TOUAREG, R32, PHAETON AND T5, V5 2.3, V6 3.2.
- Use for VW 8- and 12 cylinder engines e.g. PHAETON, B5 1.8T, GTI. FSI 2.0.
- This tool can use for most of VW-AUDI injection engines.



10/9.5/10.5/1.1' 950g

■ **Ignition coil puller for VAG**

9G3103

NEW



- Used for removing "pencil-type" ignition coil on 4-cyl.
- Application: VW - Golf 2013 ~ / Jetta 2011 ~ Audi - A3 2013 ~ Skoda - Octavia 2013 ~ Seat - Ibiza 2008 ~ / Mii 2011 ~ / Leon 2013 ~ Porsche - Macan 2014 ~



116g

■ **Calibrated ignition tester**

9G3101 / 9G3102

- **9G3101** is for HEI system
- **9G3102** is for standard system



100/6/7/2' 60g

In-line spark plug tester

88409

- Handy pocket screwdriver type.
- Checks dead spark plugs in automotive.
- CE approved.



100/9.0/10.0/1.8' Δ 65g



Top dead center (TDC) indicator set

912G9

- Application: Diesel and Petrol Engines for cars and Vans.
- A pneumatic indicator for finding top dead center (TDC) position on Petrol and Diesel engines.
- The TDC Indicator is located into the spark plug/glow plug hole, and as the engine is rotating, clearly shows when the piston has achieved TDC by visible movement of the indicator float.
- Adaptors for 8mm to 18mm spark plug and glow plug holes.
- Magnetic Attachment for hand free use.



40/7.7/8.7/1.2' Δ 195g

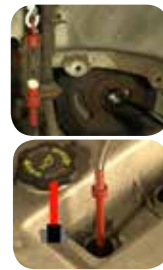

Diesel fuel pump timing set

911G9

NEW

- This precision measuring instrument is designed for resetting the timing position on diesel engines with the following fuel pumps: Bosch, EP/VE Rotory, Kikki, Nippon Denso, Cav Roto Diesel, Top Entry fuel pumps.
- Applicable diesel engines: Alfa Romeo, Audi, BMW, Daihatsu, Fiat, Ford, Isuzu, Iveco, Lancia, Land Rover, Mazda, Mitsubishi, Nissan, Renault, Rover, Vauxhall and VW etc.
- Reading of gauge: 0.01mm



12/11.4/12.4/1.3' Δ 959g

13pc Diesel and petrol engine timing kit

913G3

- For use on Audi, Citroen, Peugeot, Volkswagen and Volvo diesel and petrol engined cars and light commercial vehicles.
- After use, remove all setting pins & locking plates. Turn the engine over twice by hand to complete a full cycle. Regain T.D.C. (top dead center) & insert setting tools to re-check the alignment is correct. Remove setting tools and check there is no obstruction by turning the engine over twice by hand again to complete a full cycle.



20/22.1/23.5/1.4' Δ 1.1Kg

Camshaft locking tool

9G1201

ECOTEC suitable for 16V 1.8/2.0 liter engines.



36/3.24/4.24/2.6' Δ 90g



Camshaft locking tool

9G1202

ECOTEC suitable for 16V 1.4/1.6L engines



72/9.36/10.36/1.5' Δ 130g



Camshaft locking tool

9G1203

- For use on SAAB & VAUXHALL OPEL
- VAUXHALL CAVALIER 2.5I, CALIBRA 2.5I
- VECTRA 2.50, MEGA 2.5/3LIT, SINTRA 3LIT
- SAAB 900 2.5, 9000 3.0 V6



36/2.52/3.52/2.8' Δ 70g



Camshaft locking tool

9G1204



- For use on SAAB & OPEL
- VAUXHALL CAVALIER 2.5I, CALIBRA 2.5I
- VECTRA 2.5/3, OLIT, SINTRA 3LIT
- SAAB 900 2.5, 9000 3.0 V6

48/3.36/4.36/4.36/1' 70g

Camshaft locking tool

9G1205



- For rover K16 DOHC engines. Locks camshaft during servicing etc.
- Before use refer to the vehicle manufacturers workshop manual.



60/3.75/4.75/3.3' 63g

Flywheel holding tool

9G0605



For use on CITROEN, FIAT LDV & PEUGEOT.



120/9.0/10.0/1.5' 75g

Universal twin/4 cam lock (gas and diesel engines)

9G2401



- It's designed to lock twin camshafts to timing marks during timing belt replacement. Fit onto sprockets and extend to lock in to sprocket teeth adjustable arms.
- To fit various diameters and tooth pitch. Also suitable for locking between cam and diesel injection. pump sprockets.
- One man operation.



32/11.8/12.8/4.2' 370g

Engine timing tools set for Vauxhall/Opel diesel 1.9 CDTI

905G16



- Suitable for timing belt replacement on Vauxhall/ Opel and Saab vehicles fitted with 1.9CDTi/TiD engines.
- Kit contains camshaft alignment screws, crankshaft pulley alignment tool and tensioner pin.



20/13.4/14.0/0.9' 670g

Engine timing Tool set for Vauxhall/Opel

920G2

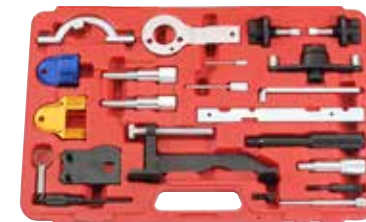

- Changing the timing belt Suitable for identical engines in e.g: Saab, Renault, etc.
- Locking the camshaft and crankshaft.
- Diesel engine 1.3CDTi 16V , 1.9CDTi , 2.0DTi , 2.2DTi
- Application for Agila, Combo-C, Corsa, Frontera , Omega, Sintra , Tigra Petrol engine 1.0 12V / 1.2 16V(since 97) 1.4 / 1.6 / 1.8 / 2.0 / 2.2 16V (since 95) Application for Agila , Astra , Corsa , Frontera , Omega , Sintra , Speedster, Tigra , Vectra , Zafira

5/19.0/21.5/1.7' 3800g

Engine timing tool set for Vauxhall/Opel

907G17



- For checking and adjusting of engine timing.
- Applications:Adam, Ampera, Astra-J, Aveo, Corsa-D, Insignia, Meriva-B, Mokka, Zafira-C Tourer (1.0, 1.2 and 1.4 petrol engines).



5/10.5/11.5/0.8' 2100g

Engine timing tool set for Vauxhall/Opel

907G18



- For checking and adjusting of engine timing.
- Application:Adam, Agila - B, Astra - J, Cascada, Combo, Corsa - D, Meriva - B, Mokka, Zafira Tourer (1.0, 1.2 and 1.4 petrol engines).



5/7.9/8.9/0.8' 1580g

■ Timing tool kit (for GM 1.3 CDTI diesel engine)

904G5



- This set use for GM 1.3 CDTI diesel engine.
- The kit include flywheel locking pin, camshaft setting tools, tension locking pin.

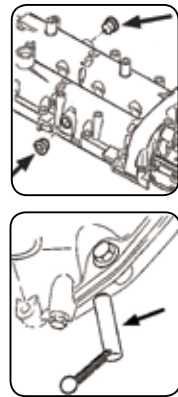

48/22.0/23.0/2.7' 280g

■ Diesel engine locking tool set for Opel / Renault / Nissan

911G5



- Prevent the belt tensioner of engine camshaft from turning when changing a timing belt or during other engine repairs.
- Applicable:
Renault: Clic, Megane, Scenic, Kangoo, Trafic, Master (99-04).
Nissan: Micra, Kubistar, Primastar.
Opel: Vivaro, Movano engine:1.5, 1.9, 2.2, 2.5 DCI. (K9K G9U).

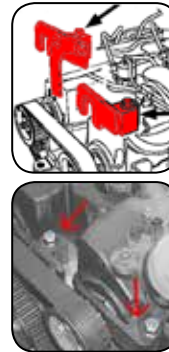

10/20.4/21.0/1.4' 2040g

■ Engine timing tool set - Renault

917G1



- This comprehensive timing tool set can correct engine timing when replacing the timing belt.
- Applicable : Renault

5/26.1/27.1/3.5' 5.2Kg

■ Engine timing tool set for Renault

905G20



- This new camshaft pulley setting tool holds two pulleys in place whilst changing the cam belt and correct engine. timing to be performed when changing the timing belt.

- Applicable:Renault, 16V & K4J, K4M & F4P, F4R.
1.4 16V K4J.
1.6 16V K4M.
1.8 16V F4P & F4R (lagunaII).

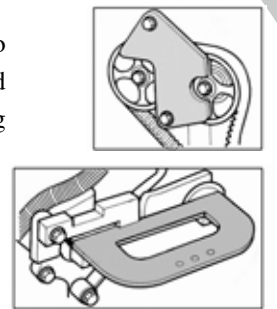

10/22.7/23.7/2.6' 2270Kg

■ Diesel engine timing tool set for RENAULT, NISSAN, OPEL

908G12



- This engine timing tool set includes important tools for Chain driven dCi diesel engines.
- This is a Chain driven engine and not considered a service time.
- The Chain will only need replacement or checking if the sprockets or tensioners are dismantled.
- Applicable:RENAULT 2.0 dCi M9R engine
OPEL 2.0 CDTi M9R engine
NISSAN 2.0 dCi



10/22.0/23.0/1.6' 2200g

■ Timing locking tools - Renault

902G5



- Can be used for RENAULT LAGUNA 2.0 IDE (2001-2005) F5R engine.

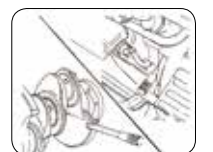

30/16.0/17.0/1.6' 530g

Renault timing kit (DCI engines)

903G5



- LAGUNA, KANGOO and CLIO-DIESEL
- Crankshaft timing PIN-MOT 1489 1.5 DCI
- Camshaft timing PIN-MOT 1430 1.5 DCI
- Crankshaft timing PIN-MOT 1054 1.9 DCI

60/14.4/15.4/1.1' 2.45Kg

Engine timing tool set for RENAULT 1.8 / 2.0 16V

907G15



- Specially designed to lock the camshaft sprockets on Renault 1.8/2.0 16v petrol engines.
- Required for releasing the camshaft sprocket bolts when timing engines, after belt replacement.
- Applicable: RENAULT 1.8 16V-



F4P 770/722/770/771/772/773/774/775
 RENAULT 2.0 16V -
 F4R 700/701/712/713/714/715/720/730/732/736/738/740/741/744/746/747/760/761/762/763/764/765/766/767/770/771/774/776/784/786/787/790/792/794/795/797/830

15/15.0/16.0/0.86' 1000g

Timing locking tools for FORD

905G8



- This set is essential for replacing the cam belt on FORD FOCUS/CMAX 1.6 TI-VCT with engine code HXDA (2003-2007) and 2.0 TDCI with engine codes G6DA, G6DB & G6DC 2003-2007.
- Also required flywheel locking tool and adaptors.

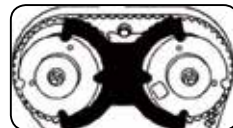

10/8.4/9.4/0.8' 830g

Engine timing tool set - Ford, Mazda

922G2



- This comprehensive timing tool set can correct engine timing when replacing the timing belt.
- Applicable : Ford, Mazda



5/16.5/17.5/2' 3.3Kg

Engine timing tool set for FORD

911G6

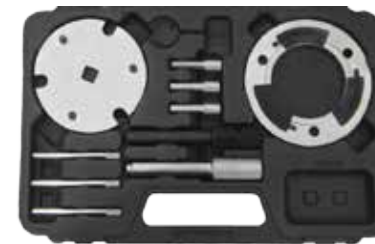

- This tool set comes with retention tools and injection pump removal / installation tools for Ford 2.0 and 2.4 Duratorqu diesel engines.



- Application: Ford Mondeo 2.0 / 2.2 TDDi / TDCi(01 -07); Ford Transit 2.0 / 2.2 / 2.4 TDDi / TDCi (00 - 08); Jaguar X-Type 2.0 / 2.2 D (03 - 08); LDV Convoy 2.4 TD / Tdi (02 - 06)

- Engine Codes: ABFA, D5BA, D6BA, F3FA, FIFA, FMBA, FMBB, D2FA, D3FA, D4FA, D0FA, F4FA, FXFA, H9FA, HJBA, HJBB, HJBC, HJBE, N7BA, N7BB, QJBA, QJBB, QJBC, SDBA

10/16.0/17.0/1.2' 1864g

Engine timing tool set for FORD

916G5



- Combination kit of setting and locking tools suitable for a wide range of Ford petrol & diesel engines.
- Also suitable for these engines fitted in Land Rover, Mazda, PSA, Suzuki and Volvo vehicles.
- Kit consists of camshaft, crankshaft/flywheel and tensioner locking tools, plus camshaft sprocket remover.

- Application: Petrol: fiesta 1.25/1.4/1.6 (95-08), focus 1.4/1.6/1.8/2.0 (98-08) 1.6 VCT-Ti (04-09), C-Max 1.8/2.0 (02-08) 1.6 VCT-Ti (04-09), fusion 1.25/1.4/1.6 (02-08), Mondeo 1.8/2.0 (98-08), Puma 1.7 (97-02), Tourneo Connect 1.8 (02-06), Transit Connect 1.8 (02-06)
- Diesel: Courier 1.4/1.6/1.8 (00-02), fiesta 1.4/1.6/1.8 (02-09), focus 1.6/1.8/2.0 (98-00), C-Max 1.6/2.0 (03-08), fusion 1.4 (02-08), galaxy 2.0 (06-08), Mondeo 2.0 (07-08), S-Max 2.0 (06-08), Tourneo Connect 1.8 (02-08), Transit Connect 1.8 (02-08)

5/12.3/13.5/1.28 2460g

Engine timing tool set for Ford 1.0 Ecoboost

916G6

NEW

- Contains tools vital for setting and locking the engine and for setting the position of the variable cam timing units.
- Applicable: Focus (12-), Fiesta (13-), B-Max (12-), C-Max (12-), TransitConnect (13-), Mondeo (14-), Ecosport (13-), Grand C-Max (12-), Tourneo Connect (14-), Transit Courier (14-)



5/20.25/20.95/1.8' Δ 4292g

Engine timing tool set for Ford 2.0 Ecoboost

905G22

NEW

- The set includes cam & crankshaft alignment tool and tensioner locking pin.
- Suitable for Ford fitted with SCTi Ecoboost / Ti-VCT 2.0lt direct injection engines.
- Camshaft tool use for vehicles manufactured May 2011 and after May 2011.
- Application: Galaxy(2010-) / Mondeo(2010-) / S Max(2010-) / Focus(2011-)

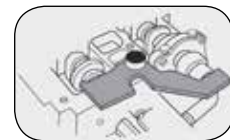
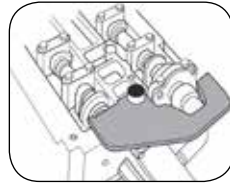

FORD Flywheel locking tool

903G11

- Flywheel locking tool with 2 adaptors
- For FORD diesel and PETROL engines.

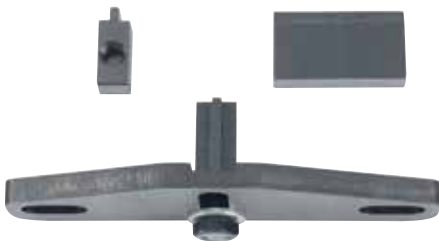

36/14.5/15.5/2.1' Δ 410g

Camshaft setting bar & TDC timing pins (Ford / Mazda)

9G1211

- Camshaft setting and locking plate.
- Updated set now covers ZETEC engines found in FOCUS, MONDEO and COUGAR from 98 on. Also covers FORD 1.6, 1.8 and twin cam 16V petrol engines.
- Crankshaft TDC location for FORD 1.25 and 1.4 engines plus the puma 1.7 engine.
- TDC pin also suitable for MAZDA 121 1.25LTR petrol engines.
- Supplied with warning tags.



100/25.8/26.8/1.7' Δ 260g

FORD Timing tool set

904G6

- Applicable : Fiesta / Puma, Fiesta / XR2i, Fiesta / Fusion, RS1800, Mondeo, Cougar, Escort / Orion, Focus, 121, Focus / Cmax Ti-VCT, Focus



48/14.0/15.0/0.8' Δ 270g



BMW (M52, M54, M56) Timing tool kit

905G1

- BENZ double vanes setup bracket.
- Application: BMW M52, M54, and M56.



5/10.9/11.9/1.35' Δ 2.18kg



Timing tool kit (BMW MINI)

907G6



- This tool kit can use for BMW MINI 2001~2006, MINI COOPER S 2002~2006 and MINI COOPER 2001~2006.

- Contents:

- Ipc - Camshaft sprocket holding tool
- Iset - Engines support bracket
- Ipc - Tensioner assembly tool



5/9.9/10.9/1'

2kg

Engine timing tool set for BMW M41, M51, M47, M57

913G6



- Installation and removal of the camshaft / hydraulic chain tensioner.
- Checking and adjustment of camshaft timing.
- Easily accessible operating instructions including cross references to original part numbers.
- Spare parts optionally available.
- Clear arrangement of tools in high-quality plastic case.
- Application: BMW M41, M51, M47, M57.

5/19.0/20.0/1.4'

3800g

Engine timing tool set for BMW M47

905G17



- Special design for correcting timing to the marking when servicing BMW M47 2.0 16V Engines.
- Applicable: BMW M47 Engines.

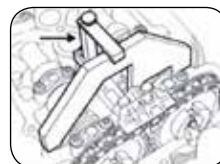

12/15.4/16.0/1.3'

1283g

Diesel engine timing tool set for BMW N47/N47S

904G11



- Installing and removal of camshaft & variable camshaft timing unit.
- Applications: BMW N47/N47S 2.0 twin camshaft diesel chain drive engines.

- BMW N47 / N47S 2.0d Diesel Engine in:

- 1Series: 118d(E81/E87)
- 120d(E81/E82/E87)
- 123d(E81/E82/E87)
- 3Series: 318d (E90/E91)
- 320d(E90/E91/E92)
- 5Series: 520d(E60/E61)
- X3 2.0d: (E83)

10/9.5/10.5/0.8'

950g



Engine timing tool set for BMW N42, N46, N46T

908G9



- Installing and removal of camshaft/variable camshaft timing unit.

- Checking and adjustment of timing.

- Applicable: E87: 118i/120i-N46

- E46: 316i/316ti/318i-N42

- E90/E91: 318i/320i-N46

- E85: Z4, 2.0L-N46

10/23.8/24.8/1.5'

2400g



Engine timing tool set for BMW N42/N46

918G3



- Suitable for the following applications: Camshaft installation and removal as well as removal and installation of the inlet camshaft and carrier assembly / Valvetronic System.

- Easily accessible operating instructions including cross references to original part numbers

- Spare parts optionally available

- Clear arrangement of tools in high-quality plastic case with soft foam insert

- Applicable: E87: 118i / 120i ; N46 engine

- E46: 316i / 316ti / 318i / 318ti ; N42 engine

- E90 / E91: 318i / 320i ; N46 engine

- E85: Z4 , 2.0L ; N46 engine

5/19.0/20.0/0.8'

3700g



Engine timing tool set for BMW N40/N45/N45T

906G5



- Applications: BMW N40 and N45(T) Twin Camshaft Petrol engine in BMW.
1 series 116. E81/E87.
3 series 316i E46/E90.
316Ci E46.
316ti. E46.



- Contents: VANOS Alignment Plate.
Camshaft Setting Plate (Inlet).
Camshaft Setting Plate (Exhaust).
Timing Chain Tensioner Pre-Load Tool.
Flywheel Locking Pin.
Camshaft Setting Plate Securing Screw.

10/20.0/21.0/1.3' 2000g

Engine timing tool set for BMW N51/N52/N53/N54

912G5



- Special design to locate camshaft in TDC position.
- Applicable: BMW N51/N52/N53/N54 engines
- Applicable models:
135iS.E82(07-08), 323i.E90/91/92/93(04-08),
325i/xi.E90/91/92/93 (04-08), 330i/xi.E90/91/92/93(04-08),
335i/xi.E90/91/92/93(04-08),
523i/Li.E60/61(04-08),X3 2.5/3.0.E83(06-08),
525i/Li/xi.E60/61(06-08), 528i/Li/xi.E60/61(06-08),
530i/Li/xi.E60/61(05-08), 535i/xi.E63/64(04-08),
630i. E60/61(04-08), 730i/Li.E65/66(04-08),X5 3.0.E70(06-08),
Z4 2.5/3.0.E85/86(05-08).E90/91/92/93(04-08)



4/24.0/25.0/2.0' 6000g

Engine timing tool set for BMW N62 / N73

905G19



- Suitable for setting and adjusting the timing on BMW 3.6, 4.0, 4.4, 4.8 N62/N62TU V8 and 6.0 N73 V12 engines.
- Kit includes camshaft setting plates, flywheel locking pin and chain pre-tensioning tool.
- Application: 540i E60/61 (05-10), 545i E60/61 (03-06), 550i E60/61 (05-10), 645i E63/64 (03-06), 650i E63/64 (05-11), 735i E65/66 (02-05), 740i E65/66 (05-08), 745i E65/66 (02-05), 750i E65/66 (05-08), 760i E65/66 (02-08), X5 4.4 E53 (03-07), X5 4.8 E53/E70 (04-10)



5/14/15/1.3' 2800g

Engine timing tool set for BMW M60, M62 (VANOS)

912G12



NEW

- For fixing the camshaft chain tensioner.
- Applicable : BMW M60, M62 (VANOS)

3/22/23/2' 7360g

Engine timing tool set for BMW N63

906G8



NEW

- Special design for locating and turning the camshaft in correct TDC position.
- Applicable: BMW N63 engine.



5/14.8/16/1.28' 2987g

Engine timing tool set for BMW N20

908G15



NEW

- Designed for fixing the camshaft in TDC position.
- The tool is used to dismantle and assemble intake and exhaust camshaft.
- Applicable: BMW N20, N26 engine



2/10.5/11.5/0.74' 5250g

Engine timing tool set for BMW N13/N18

908G16

NEW



- The tool is used to dismantle and assemble intake and exhaust camshaft and fix them at TDC position.
- Applicable: BMW N13, N18 engine

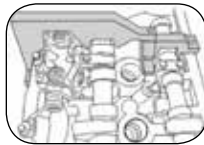

10/21/22/1.6'

2102g

Petrol engine twin camshaft setting tool kit For BMW MINI / CITROEN / PEUGEOT

910G8

NEW

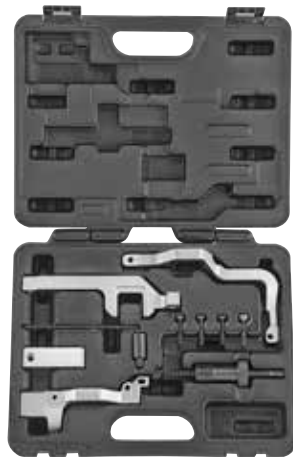

- Suitable for timing 1.4 & 1.6 16V Valvetronic direct injection petrol, chain drive engines, fitted in BMW Mini, Citroen and Peugeot vehicles.
- Application: BMW MINI:
Mini One R56 (07-09), Cooper R55/R56 (06-09), Cooper S R55/R56 (06-09)
CITROEN: C4 (08-09), C4 Picasso (08-09)
PEUGEOT: 207 (06-10), 207CC (07-10), 308 (07-10), 3008 (09-12), 5008 (09-12)



5/11.5/12.5/1.28'

2300g

Engine timing tool set for BMW, Mini, Citroen, Peugeot

905G12



- Required for removal/installation of the timing chain assembly.
- Relevant setting/locking tools for particular vehicles/engines will also be required.
- Set contains balance shaft alignment, crankshaft holding and chain tensioner tools.
- Applications: BMW N40/N45/N45T B16, N42/N46 B18, B18A, B20, B20A, B20B, N51/N52/N52K/N53/N54 Valvetronic, N53/N54 Direct Injection Non-Valvetronic, BMW Mini; N12/N14, Citroen/Peugeot; EPS(8FS)/EPS.



12/11.4/12.0/1.3'

950g

Fly wheel holder tool for BMW

905G15



- When replacing timing chain, this tool can block fly wheel.
- It helps to release and tighten down central bolts on vibration damper.
- Application: BMW (M47T2/M47TU/M57T2/M57TU/M67/N45 /N45T/N46/N46T/N51/N52/N53/N54/W17)

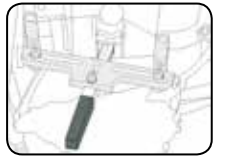

20/18.0/19.0/1.2'

900g

Engine timing tool set for BENZ M271

904G18



- This retaining device makes it possible to position the camshafts into the installation position.
- Includes a Retainer to draw in the timing chain and to retain timing chain with camshaft sprockets in mesh.
- Applicable: CLK 200K (W209), C 180K, C200K, C 230K (W203), C Sportcoupe C 160K, C 180K, C 200K, C 230K, E 200K (W211), SLK 200K (R171), C 180K (W204), CLC 180K, CLC 200K, C 180 CGI, C 200CGI, C 250CGI (W204), E 200CGI, E 250CGI (W212, C207)
- Engine Codes: E18ML (02-), DE18ML (03-05), E16ML (08-), DE18LA (09-)



6/17.1/18.1/2.6'

2850g

Engine timing tool set for BENZ

9G1218



- The use of the mounting device allows a single mechanic to replace a timing chain quickly and without any trouble.
- Application: for the 4-cylinder Mercedes petrol engine M111 - C 180/200/220/230; E 200/230; CLK 200/230; SLK 200/230; ML 230

24/11.5/12.5/2.8'

480g

Engine timing tool set for BENZ

906G7



- A timing tool set which covers a large number of models in the Mercedes range including Petrol and Diesel engines.
- Set includes Flywheel Plate Locking Tools and Camshaft Locking Pin Set.
- Application: Benz engine model 102, 103, 104, 111, 112, 113, 119, 137, 155, 156, 272/979, 273, 601, 602, 603, 604, 605, 606, 611, 612, 613, 628, 629, 640, 642.
- Also suitable for Chrysler PT Cruiser 2.2 CRD and Jeep Grand Cherokee 2.7CRD.



20/22.5/23.5/1.6' 1125g

BENZ flywheel locking tool

9G1215



- Use for BENZ M101, M102, M103, M104, M111, M601, M602.
- Used to fix the flywheel gear to remove & install crankshaft pulley center bolt.



60/13.3/14.3/0.83' 200g

Engine timing tool set for BENZ M133, M270, M274

915G6

NEW



- Special design for positioning the camshaft in TDC position.
- Applicable: 1.6L, V4 engine, A class and B class.

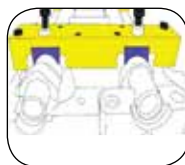

6/27.6/28.6/1.4' 4600g

Engine timing tool set for BENZ M651

903G21

NEW



- The retaining device makes it possible to position the camshafts in the installed position.
- Also for turning, installing, and removing the crankshaft pulley.
- Applicable: BENZ M651 VOLUME 2.0D / 2.2D / 2.5D engine (07~)



10/14.8/15.8/1.4' 1406g

Engine timing tool set for BENZ M156

904G19

NEW



- Used to fix and align the camshaft in correct timing angle when replacing the timing belt.
- Applicable: BENZ AMG 156.ML 63, S63L, S63, R63, E63, CLS63, and CLK63



5/8.7/9.7/0.8' 1725g

Engine timing tool set for VW, Audi

908G5

- A dedicated set of setting / locking, support and tensioner adjusting tools for VAG V6 TDI petrol engine.
- Applicable: VW 2.5 V6 diesel engines and AUDI A4, A6, A8, A11 road(97~08)

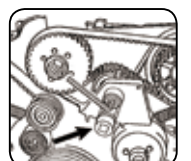
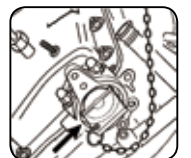

12/12.5/13.5/1.3' 1030g

Engine timing tool set - VW, Audi, Seat and Skoda

928G1

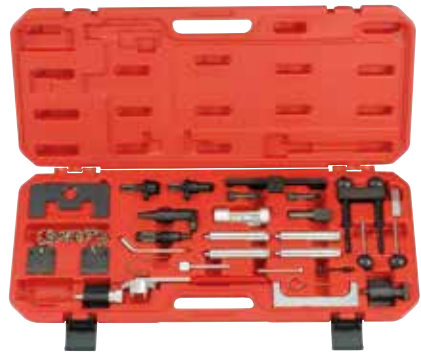

- This comprehensive timing tool set can correct engine timing when replacing the timing belt.
- Applicable : VW, Audi, Seat and Skoda

5/21.5/22.5/1.9' 4.3Kg

Timing setting tool set - VW, Audi, Seat and Skoda

929G1



- Use for AUDI, SEAT, SKODA, VW.
- AUDI: A2(01-06), A3(01-07), A4(99-07), A6(98-07)
SEAT: AROSA(99-05), IBIZA/CORDOBA(02-07), ALTEA(04-07), LEON(00-07), TOLEDO(04-07), ALHAMBRA(99-07)
SKODA: FABIA(00-07), ROOMSTER(07), OCTAVIA(00-07), SUPERB(02-07)
V W : LUPO(99-05), POLO(99-07), FOX(05-07), GOLF/BORA(98-07), JETTA(05-07), BEETLE(00-07), PASSAT(98-07), TOURAN(03-07), SHARAN(99-07), CADDY(03-07), TRANSPORTER(03-07)

5/21.5/22.5/2' 4230g

Engine timing tool set for AUDI

910G5



- Special designed set of tools for alignment camshaft lock and adjusting.
- Applications: VAG A4/A6/A8 3.2 FSI with engine AUK , A6/Quattro 2.4 with engine BDW.



5/14.0/15.0/1.2' 2800g

Engine timing tool set for VW / AUDI

913G7



- A complete set for alignment, adjustment of the camshaft, replacement of the timing chain and etc...
- To improve your working speed with this complete set.
- Applicable: AUDI Q5 2.0, A6L 2.8, 3.0T



6/20.0/21.0/2.6' 3330g

Camshaft clamp for VW / AUDI

902G18



- Special designed to align camshafts when adjusting timing.
- Applicable: AUDI A6 2005~, Q5 2.0T, A6L 3.0T
- Engine model: 6-cyl. Petrol direct injection 2.8L 4V engine

20/17.5/18.5/0.26' 875g

Engine timing tool set for VW

904G15



- Installing and removal of camshaft / variable camshaft timing unit;
- Checking and adjustment of timing;
- Application: VW: Polo (02-07), Fox (05-08)
Seat: Ibiza (02-08), Cordoba (02-08).
Skoda: Fabia (02-07).
- Engine Codes: VW: AWY, BMD, AZQ, BME
Seat: AWY, BMD
Skoda: AWY, BMD, AZQ, BME

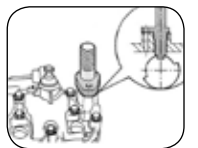

24/17.0/18.0/1.5' 708g

Engine timing tool set for VW / AUDI

907G13



- Kit includes camshaft tools, chain tensioner retainer, locking pins and tensioner bolt.
- For 2.0 FSI petrol engines since 2003.
- Application: AUDI: A3 2.0 FSI and FSI SOHC
VW: GOLF 2.0 FSI and 2.0 FSI SOHC and Touran 2.0 FSI SOHC
- Engine Codes: AUDI: AWA, BHD, BMB
VW: AWA, AXW

20/22.0/23.0/1.7' 1100g

Engine timing tool set for VW

906G6



- Special designed set of tools for camshaft locking, and adjusting.
- Applicable: VW-Transporter, LT, Crafter 2.4D, 2.5SDI, 2.5TDI, 2.5TDI Common Rail

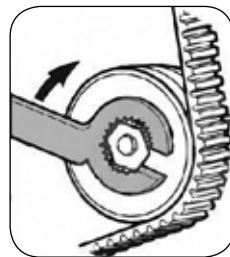

10/15.0/16.0/1.31' 1500g

Engine timing tool set for VW / AUDI

904G16



- For checking and adjusting camshaft timing when replacing timing belts or timing chains, or during repairs.
- Includes TDC adjusting tool, Locking bolt, and Setting gauge for camshaft
- Applicable: VW-AUDI 1.4L and 1.6L FSI petrol engines:



Audi - A3 (03-10)
Skoda - Octavia (04-09), Fabia (07-09), Roomster (06-09), Superb (09-10)
VW - Polo (02-08), Golf (03-09), Golf Plus (05-09), Jetta (06-09), Passat (05-09), Touran (03-09).

10/12.0/13.0/1.2' 1200g

Engine timing tool set for VW / AUDI

914G5



- Comprehensive kit required for service work on timing chain, cylinder head and HP pump, and engine timing applications on VAG 2.7 - 3.0 TDi V6 and 4.0 - 4.2 TDi V8 common rail diesel engines.
- Applications: Audi - A4, A5, A6, A6 Allroad, A8, Q5, Q7,
VW - Phaeton, Touareg

10/20.0/21.0/1.6' 2000g

Engine timing tool set for VW

908G13



- For removing and installing camshaft drive gear and eliminating play in gear train - for locking of both camshafts and crankshaft.
- Applicable: VW T5 Touareg and Transporter 2.5 TDI PD and 4.9D / TDI models.
- Engine codes: BAC, BLK, BPD, AXD, AXE, BLJ, BPC, and AYH

2/15.5/16.5/0.8' 7750g

Engine timing tool set for VW, AUDI, SKODA

908G18

NEW



- Designed to allow removal and replacement of the timing chain and camshaft sprockets on the 1.8/2.0 TFSi and TSi petrol engines
- Applicable: VW-Tiguan, CC, Golf VI, Passat, Beetle/Maggiolino, Eos, Scirocco.
AUDI-A4, A4 quattro, A5 Coupe/Cabriolet, A5 Sportback, Q5, TT
SKODA-Octavia II, Superb, Yeti



10/12.5/13.5/1.3' 1250g

Engine timing tool set for VW, AUDI

904G20

NEW



- For check and adjustment of engine timing.
- Applicable: 1.0L 3-cyl. petrol engines VW up, SKODA Citigo, SEAT Mii since 2011

10/11.5/12.5/1.4' 1125g

Engine timing tool for VW/Skoda/Seat

906G10

NEW



- For checking and setting the engine timing suitable for following VAG engines:
1.2 / 1.4 L 4-cylinder direct injection with turbocharger, built in Audi A3/ VW Golf from 2013
1.0 L 3-cylinder, built in Seat Mii / Skoda Citigo / VW Up from 2011.



10/16.5/17.5/1.9' 1638g

Engine timing tool set for VAG 1.6 / 2.0TDI

910G9

NEW

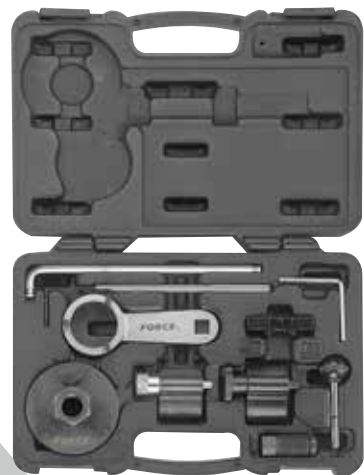

- Designed to fit the newest Common Rail diesel engines which are significantly different from the older PD engines.
- These Common Rail engines combine belt and gear drives by using a toothed belt to transfer the drive from the crankshaft to one of the cam shafts then using gears to transfer the drive from one cam to the other.
- Applicable:
Volkswagen: Golf, Golf Plus 1.6 TDI (since 2009)
Tiguan, Passat, Eos, Golf, Golf Plus 2.0 TDI (since 2008)
Audi: A3 1.6 TDI (since 2009)
A3, A4, A6, Q5 2.0 TDI (since 2007)
Seat: Exeo 2.0 TDI (since 2009)

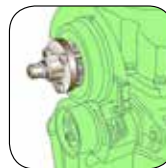

10/18.5/19.5/1.6' 1850g

Engine timing tool set for VW, AUDI, SKODA, SEAT

909G10

NEW



- Includes essential tooling required to remove the camshaft adjuster valves and a useful crankshaft pulley holding tool.
- Fits a wide range of VAG group 1.8 & 2.0 petrol engines.
- Applicable: Audi - A3, A4, A5, A6, Q3, Q5, TT
VW - Golf, Beetle, Jetta, Scirocco, Eos, Passat, Passat CC, Tiguan, Sharan, Amorok
Skoda - Yeti, Octavia II, Octavia III, Superb
Seat - Leon, Toledo, Altea, Altea XL, Exeo, Alhambra



Timing chain test tool for VW, Audi, Seat, Skoda

904G21

NEW



- Application: Checking elongation of timing chain.
- Engine: petrol 1.2L TSI - / 1.4L TFSI



3-in-1 Bosch timing tool for VW

904G17



- Suitable for timing Bosch VE injection pumps.
- Includes M8, M10, and M12 adapters.
- Use in conjunction with Dial gauge
- Applicable: Bosch VE fuel pump, Diesel Kiki, and Nippondenso pumps.

72/8.0/9.0/1.2' 111g

■ Crankshaft seal installer tool for VW / AUDI

9G0129

NEW



- Special design tool to renew crankshaft sealing flange.
- Applicable: 16v,1.4,1.6 engine of VW, AUDI,SKODA,SEAT.

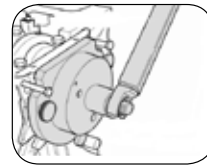
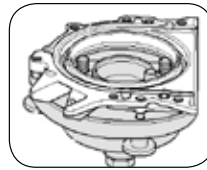

6/11.5/12/0.9' 1621g

■ Camshaft central valve tool for VW / AUDI

902G13



- Assembly Tool for installation and removal 4/3-way central valve for camshaft adjustment.
- These tools have offset pins.
- Applicable:Audi A3 (2003up).A4.A5.Q5 , VW Passat (2006 up).Passat CC (2006 up)



50/13.0/14.0/1.2' 250g

■ Camshaft adjusting socket for AUDI

9G1210



- Special groove nut socket to turn the camshaft adjuster into position.
- Camshaft adjusting socket used to adjust variable valve timing on the exhaust side camshaft to basic position.
- Applicable:Audi A4 , A6 (3.0L V6 5V)



100/9.1/10.1/2' 91g

■ Camshaft alignment tool

9G1216



- This tool is used for holding both camshafts at the TDC position when replacing the timing belt.
- Used AUDI & VW models with V8 motors with 5 valves per cylinder (except S4)



10/21.0/22.0/0.46' 2050g

■ Camshaft alignment tool

903G14



- This tool is used to hold both camshafts at the TDC position while replacing the timing belt.
- Used AUDI models with V6 engine, 2 valves per cylinder.



10/23.2/24.2/1.9' 2220g

■ Camshaft alignment plate for VW, AUDI

9G1209



- Specially designed to align the camshafts to proper position when adjusting and assembling.
- Applicable: VW-PASSAT, VR-6



Part no.	Material	packing	g
9G1209	PVC	60/5.0/6.0/0.6'	50

■ Camshaft alignment tool

902G6



- For Audi 3.0L, VG SV used in 2002 ~ 2005
- For Audi A4 and 2002 ~ 2004 Audi A6



5/12.5/13.5/0.5' 2.1kg



Camshaft locking tool for VW

9G1206



- For locking the camshaft pulleys when changing the toothed belt.
- Engine repairs on 4-valve, 4-cylinder injection engines VW LUPO since 1999, POLO since 1995, CADDY since 1996, POLO CLASSIC, VARIANT since 1996, NEW BEETLE 1.4L since 1999 GOLF 1.4L, 1.6L since 1998, BORA 1.4L, 1.6L since 1999.



60/22.5/23.5/1' 375g

Camshaft locking tool

903G10



- VW: POLO/CLASSIC, GOLF / BORA, BETTLE, CADDY (97-06).
- Enable replacing the timing belt without removing the cylinder head cover.



60/22.8/23.8/0.65' 380g

Engine timing tool set for VW / AUDI

902G15



- Specially designed to hold and align the camshaft.
- Applicable: VW - Golf 1998~, Bora 1999~, Passat 1997~, Sharan 1996~, Touareg 2003~, Phaeton 2003~, Transporter 1991~ Audi - A8 1994~, Audi TT 1999~
- Engine model: 6-cyl. injection engine (4-valve), 8-cyl. injection engine (W8), 12-cyl. injection engine (W12)



24/22/23/1.2' 861g

Engine timing tool set for VW / AUDI

902G16



- Specially designed to install Hall sender screens into crankshaft adjuster when setting the crankshaft timing.
- Applicable: Audi A6L, A8L 4.2 engine.
- Engine model: V8 BAT 4.2 engines

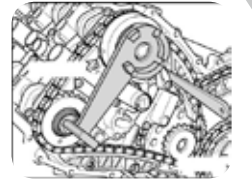

20/21.6/22.6/1.1' 1025g

Engine timing tool set for VW / AUDI

902G17



- For locking camshafts when checking valve timing
- Applicable: Audi A6L, A8L 4.2 engine.
- Engine model: V8 BAT 4.2 engines

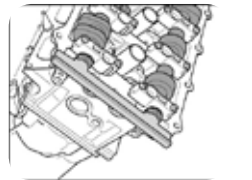

24/13.7/14.7/0.65' 521g

Engine timing tool set for AUDI

902G19



- This comprehensive set of tools enables the correct engine timing to be made when replacing the timing belt.
- Applicable: PORSCHE cayenne 4.5L, 4.8L AUDI Q7.

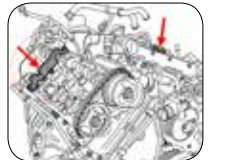

10/19/20/0.6' 1842g

Engine timing tool for VAG

9G0807



- Special design to hold the chain and tensioner in position during assembly and disassembly.
- Applications: Audi - A3, S3, A4, A6, TT, VW - Beetle, Bora, Golf, Passat, Seat - Ibiza, Cordoba, Leon, Toledo, Alhambra, Skoda - Octavia.

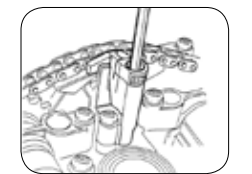

100/5.5/6.5/1.6' 55g



AUDI Crank locking pin

9G1302



- This pin is used to lock the crankshaft at the TDC position while replacing the timing belt.
- Applicable: AUDI 3.0L V6 5 valve.
- Size: M12x1.5



144/15.0/16.0/1.5' 95g

VW/AUDI Crank locking pin

9G1303



- This pin is used to lock the crankshaft at the TDC position while replacing the timing belt or removing the crankshaft bolt.
- Applicable: VW/AUDI models with 2.7 & 2.8 liter V6 engines.
- Size: M18 x 1.5



144/18.0/19.0/1.5' 120g

Crank locking pin for AUDI

9G1305



- This pin is used to lock the crankshaft at the TDC position while replacing the timing belt or removing the crankshaft bolt.
- Size: M14 x 1.5
- Application: AUDI A6 2005 6 cylinder engine 2.4 liter & 3.2 liter FSI



100/8.5/9.5/1.1' 78g

Crank locking pin for VAG

9G1306

NEW



- This pin is used to lock the crankshaft at the TDC position while replacing the timing belt or removing the crankshaft bolt.
- Applicable: VAG FSI and TFSI 1.4L and 1.6L engines
- Size: M14 x 1.5

82g

Timing tool set for VAG 2.0 TDI PD

906G4



- Timing tool set for VAG 2.0 litre TDI PD DOHC engines fitted to AUDI A4, A6 SKODA OCTAVIAII and VOLKSWAGEN GOLF, GOLF PLUS, JETTA and TOURAN models.



40/19.0/20.0/2.1' 415g

Crankshaft locking tool

9G1208



- For VOLKSWAGEN, AUDI, SEAT, SKODA, 2.0 TDI engines.



100/20.0/21.0/1.7' 190g

Crankshaft locking tool for VW

9G1301



- For use on VOLKSWAGEN BORA, GOLF, LUPO & POLO TDi's.



100/19.0/20.0/1.7' 1.9Kg

Locking tool set for VW, Audi

902G2



- For use on AUDI, VOLKSWAGEN, SEAT, SKODA with TDI PD and V6 engines.



Contents:
Injection pump locking pin
tensioner locking tool
crankshaft locking tool.

6/14/15/1.6' 234g

Engine timing tool set for PORSCHE Boxster, 911

908G17

NEW



- Comprehensive 8-piece tool kit to establish proper engine timing when performing major engine / valve train service.
- Applicable: Porsche Boxster 2.5, 2.7, 3.2(engine type 986, 987), Porsche 911 Carrera 4S 3.6, 3.4(engine type 996, 997)

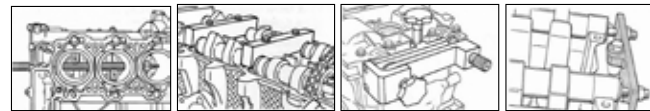

3/17.2/18.2/2.2' 5730g

Engine timing tool set for PORSCHE

903G22

NEW



- Special design to align the engine timing on PORSCHE.
- Applicable: PORSCHE 997 series.



10/10/11/10.8' 962g

Engine timing tool set - Peugeot, Citroen

935G1

- This comprehensive timing tool set can correct engine timing when replacing the timing belt.
- Applicable : Peugeot, Citroen

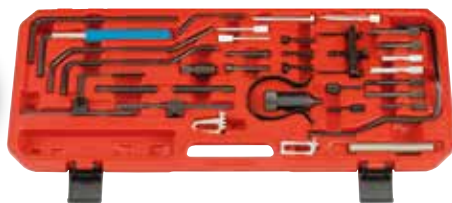

5/18.0/19.0/2' 3.6Kg

Engine timing tool set for CITROEN / PEUGEOT

911G7



- This comprehensive set of tools enables the correct engine timing to be made when replacing the timing belt.
- Suitable for use on most of the recent cars with either HPI (petrol) or HDI (diesel) engines.
- Applicable : Citroen and Peugeot twin cam 16V
Citroen: Xsara / Picasso C4, C5 , Evasion / Synergie , C8 , Jumpy / Dispatch
Peugeot: 206, 307, 406/Coupe, 607, 806, 807, Expert.
- Engine Codes: EW7J4 , EW10J4 , EW10J4S , EW10D-Hpi , EW12J4

10/15.0/16.0/1.6' 1500g

Engine timing tool set for FIAT

934G1



- Petrol Engines:
FIAT Brava, Bravo, Barchetta, Cargo, Coupe, Marea, Palio, Weekend, Punto, Multipla, Stilo, Idea Doble, Twin Cam Engines 1.2 1.4 1.6 1.8 16V.
- Diesel Engines:
FIAT Brava, Bravo, Marea/ Weekend, Palio, Punto, Multipla, Doblo, Ulysse, Ducato, Stili JTD Diesel Engines 1.9D/TD 1.9JTD 2.4TD/JTD.



5/23.4/24.4/1.7' 4680g

Engine timing tool set for FIAT

907G16



- Kit includes all the diesel timing tools for Fiat Punto , Ducato, Tempra, Tipo and models with an adjustable camshaft timing belt pulley.
- Applicable: FIAT : Punto 1.7D/TD/CAT/EGR (96-97) , Ducato 1.9D/ TD (94-02) , Tempra 1.9D/TD (94-02) , Tipo 1.9D/ TD (94-02)

10/14.0/15.0/0.9' 1400g

Engine timing tool set for Fiat 1.2 8V & 1.4 16V

910G7



- Kit consists of crankshaft locking tool, camshaft setting plate and belt tensioner adjuster for the 1.2 engine, and additional sprocket locking tool and alignment fixture for the camshaft on the 1.4 WT engine.
- Applicable:New 500(07-08) / Idea(04-08) / Linda(07-08) / Grande Punto(07-08) / Doblo(05-08) / Panda EV02(05-08)
- Engines:1.2 8V / 169A4.000, 199A4.000 / 1.2 8V / 188A4.000 (EVO2) /1.4 16V /350A1.000



10/10.0/11.0/0.8' 1000g

Engine timing tool set for FIAT

903G23



NEW

- Includes camshaft setting tools and flywheel/crankshaft locking pin.
- Applicable: Fiat: 500 (07-08), Doblo/Cargo (04-06), Grande Punto (05-08), Idea (04-08), Linea (07-08), Panda (03-08), Punto (03-08)

50/13/14.5/1.3' 226g

Engine timing tool for VOLVO

912G10

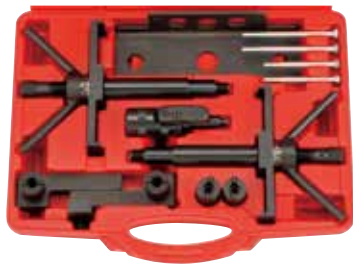

- For alignment of the cam and crankshafts.
- Also enables correct installation of the camshafts with the cam cover.
- Applicable: VOLVO models 850, 960, S40, S70 and S90.



4/22.0/23.0/1.6' 5500g

Crankshaft harmonic balancer holder tool for BMW

9G1220

NEW



- Holds vibration damper when loosening and tightening center crankshaft bolt.
- Application:BMW E39/E46/E60/E61/E81/E83/E90/E91



10/18/19/1' 1674g

Crankshaft pulley holder tool for BENZ M272/M273

9G1219



NEW

- For removal and replacement of the crankshaft bolt.
- Application: BENZ M272, M273 .



10/20/21/1' 1936g

11pc Universal pulley holder & fan clutch set

911G1



- This set is designed to remove and install fan latches & to hold the camshaft pulley.
- Used for most of the cars.
- Contains different taps to fit any cars and pin width can adjust.
- Can adjust different width from 40m/m to 220m/m.
- Size available: 6mm~10mm, 8mm~11mm, 10mm~12mm, 11mm~16mm



6/19.1/20.1/3.5' 3180g

Camshaft & injection pump sprocket holding turning tool

9G0606



- Can be used for universal.
- Essential tool called for on many timing belt/engine timing application.
- Used to counter-hold camshaft or injection pump sprockets to allow release of retaining bolt.

24/24/25/2.5' 990g

TOYOTA Cam wrench tool kit

915G1



- Universal design fits many different types of pulleys having slots or holes, including camshaft pulleys and crankshaft pulleys.
- Wrench is adjustable from 1-1/4 inch to 5 inches; works with 1/2" ratchet or breaker bar.

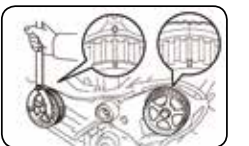

16/18.3/20.5/2.2' 1140g

■ Universal timing gear holder

9G0617



- Used to hold cam gear while removing cam shaft bolt.
- Allows adjustment of cam gear once installation is completed
- Single sliding design makes it quick and easy to adjust.
- Three positions for wider application range.
- Range: 50 ~ 150 mm.



20/21/23/2.2' 143g

■ Counter hold tool for VW / AUDI

9G0616

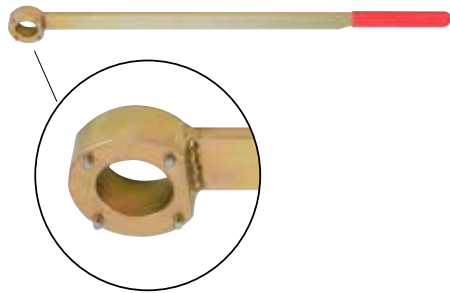

- This tool is used for stopping the engine crankshaft pulley/vibration damper when center bolt for crankshaft is under installation or disassembly.
- 810mm (32" inches) long, with 4 pins, size 5mm with 42mm pin spacing.
- Application:Mainly used for car Audi A3 (2004 -up), engine 1.8 liter TFSI (chain drive), also fits Audi A4 / A5 / Q5 (2009 -up), engine 2.0 liter TFSI (chain drive).



6/15.0/16.0/1.1' 2290g

■ VW, AUDI belt pulley holder

9G0607

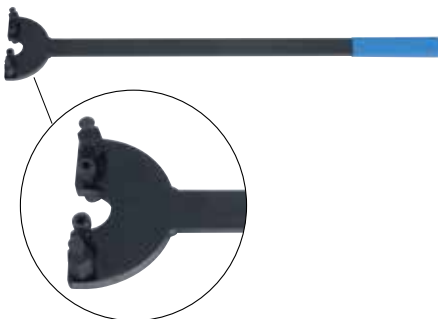

- Special design to hold the belt pulley on VW, AUDI.
- Applicable:
VW:LUPO, POLO/CLASSIC, GOLF, BORA & CADDY.
AUDI:A2

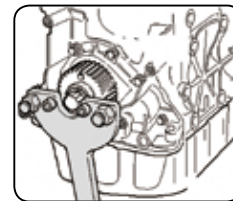

6/12.3/13.3/1.1' 2050g

■ VW, SEAT Belt pulley holder

9G0608



- Special design to hold the belt pulley on VW.
- Applicable:
VW: LUPO, POLO/CLASSIC, BEETLE, GOLF, BORA & CADDY.
SEAT: IBIZA/CORDOBA

6/12.9/13.9/1.1' 2150g

■ Pulley holder tool (teeth type belt)

9G0708



- Ideal for removing and assembling any type of grooved pulley. This modern tool keeps the grooved pulley firmly locked.
- Enables to tighten or to untighten without any difficulty, the pulley locking screw.
- Has more functions than a standard strap or chain wrench, and will not damage components. Ideal for alternator and water pump pulleys, but also essential for electric motors of compressors, washing machines, tool machines etc. Also suitable to rotate the camshaft when timing the engine and to remove oil and gasoline filters.



36/21/22/2' 586g

■ Pulley holder tool (groove type belt)

9G0709



- Ideal for removing and assembling any type of grooved pulley. This modern tool keeps the grooved pulley firmly locked.
- Enables to tighten or to untighten without any difficulty, the pulley locking screw.
- Has more functions than a standard strap or chain wrench, and will not damage components. Ideal for alternator and water pump pulleys, but also essential for electric motors of compressors, washing machines, tool machines etc. Also suitable to rotate the camshaft when timing the engine and to remove oil and gasoline camshaft filters.

36/21/22/2' 586g

■ 1/2"Dr. Hand impact wrench

9G0712



- Special design to replace the harmonic balancer pulley.
- It will turn when you try to remove the center nut.
- Applicable: flywheels, pulleys, flanges and etc.

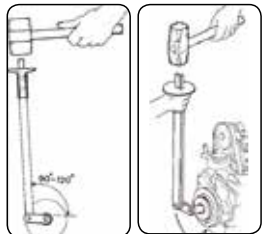

12/18.0/19.0/0.9' 1375g

7pc BENZ & BMW Fan service wrench set

907G3



- Removes lock nuts on thermo-Viscous fans found on FORD BMW ... many vehicles.
- Removes lock nuts on thermo-Viscous fans found on FORD Mercedes... many vehicles.
- Allows the technician to hold the water pump pulley in place while loosening the radiator fan.
- To allow removal of the visco-coupling on the cooling fan.
- Required to remove the radiator fan hub, the reaction spanner is bolted to the front face of the hub.
- Special open-ended spanner to allow removal and replacement of the radiator fan hub.
- The three-in-one design allows servicing three separate areas of repair. All of which require a specialty tool due to their confined locations.

5/19.3/22.0/2.7' 3860g

Reaction wrench

9G0704



- For locking of deep-drawn water-pump pulleys on VW and Audi engines. As they are used when E.G. an air conditioning is also built in.
- Safe locking of the water-pump pulley.
- Easy loosening of stubborn bolts on the water-pump pulley.



36/19.8/20.8/2.1' 550g

Reaction wrench (1/2" DR.)

9G0705



- For locking the pulley on the water-pump on VW Polo, Golf, Passat Audi 80/A4.
- The 1/2" drive in the tools handle enables an extension of the tool by E.G. a ratchet.
- Easy loosening of stubborn bolts on the water-pump pulley.



72/21.0/22.0/1.5' 291g

Power steering pump pulley kit

907G12



- Thompson & Ford C111, C2 power steering pumps found on Ford, GM & Chrysler vehicles.
- A disconnect tool to release the power steering line from pump on 1989-current GM pickups 1/2T, 3/4T & 1T.



20/19.0/20.0/2.0' 950g

Camshaft drive belt pulley puller

905G4



- Special puller designed for pulling camshaft pulley wheels on 4 & 6 cylinder, V6 & V8 engines of VW and AUDI petrol-engined cars.



10/16.4/16.9/1.1' 1.64Kg

22pc Alternator repair kit set

922G3



- Removes and installs press-on-type belt drive accessory pulleys.
- Applicable:VW, Audi, Seat, Mercedes Benz, Renault, BMW, Ford Renault, Fiat, etc....
- Specification:A. 17mm HEX Socket ,



- B. 22mm HEX Socket
- C. 22*28mm HEX Socket , D. 21*28mm HEX Socket
- E. 19*28mm HEX Socket , F. 35mm Round W/4pin
- G. 38mm HEX W/3pin , H. Ø 17.6*15mm HEX*33T
- I. Ø 19.2*15mm HEX*33T , J. Ø 19.3*22mm HEX*33T
- K. 3/8" Dr.* M10x72mmL W/ Ø14*12mm HEX*31T
- L. 1/2" Dr. * T50x110mmL W/ Ø19.5*17mm HEXx33T
- M. 1/2" Dr. * M10x110mmL W/ Ø19.5*17mm HEXx33T
- N. Bit H10 socket w/10mm hex drive end

4/8.7/9.7/0.87' 2169g

VW, AUDI V-belt pulley remover

67402



- Special design to stop the pulley and remove the center bolts to remove the V-belt pulley at the generator.
- Use with 17mm wrench.
- Applicable: VW GOLF, VENTO, PASSAT, AUDI A3 and VOLVO



144/5.0/6.0/1.5' 50g

2pc M10 Alternator tools

674



- 1pc 1/2"DR. Spline (XZN) socket bit M10x110mmL
- 1pc Reaction corkscrew cap 33 teeth-Ø19mm-17mm hex
- Application : VW-Audi, Skoda, Porsche, BMW, Ford, Mercedes-Benz etc.



100/18.2/19.2/1.5' 110mm 182g

2pc T50 Alternator tools

678



- 1pc 1/2"DR. Torx socket bit T50x110mmL
- 1pc Reaction corkscrew cap 33 teeth-Ø19mm-17mm hex
- Application: Mercedes A Class.

100/21.2/22.2/1.5' 110mm 212g

Universal camshaft sprocket puller

905G18



- Hold the sprocket and undo the retaining bolt or nut and remove
- This tool enables the removal of the camshaft sprocket on a wide range of vehicles
- Suitable: 45 – 70mm



Gear puller

909G2



- Depth: A 68mm, B 90mm
- Outside: A 40-120mm, B 132-195mm



6/17.0/18.0/1.2' 2830g

Balancer puller & installer

945G1



- A professional tool set for balancer replacement.
- Built-in bearing makes balancer replacing job easy and damage-free.
- 4-Slot puller plate plus 9 threaded adapters fit to balancers on most engines.



6/14.6/15.6/1.3' 2430g

Heavy duty universal & GM harmonic balancer puller

921G1



- Heavy duty forcing screw & bolt kit suits most harmonic balancers, timing gears & pulleys with 2/3" tapped.
- GM forcing screw & bolts suits gm 3.8 l v6 balancer pulleys.
- Bolt sizes: 1/4" UNF x3" (3 pieces) / 10mm x 50mm (3 pieces) / 5/16" x 2" (3 pieces) / 80mm x 80mm (3 pieces) / 3/8" x 2" (3 pieces) / 3/8" x 4" (2 pieces)

5/14.4/15.4/1.5' 2880g

Puller, Harmonic damper pulley (Chrysler, GM)

906G9

NEW



- New spring-loaded legs allow for leg position retention
- Provides greater ease and control when installing the puller in confined areas
- Removes harmonic damper pulleys found on many Chrysler and GM engines
- Used on autos, pickups, SUVs, and vans.



16/23.5/24.5/1.5' 1470g

Dual mass flywheel wear testing tool

922G5



- Indispensable tool for the quick and professional wear tests of Dual Mass Flywheels (DMF).
- Tests can be performed directly on the vehicle if the clutch has been removed.
- The test involves checking the rock allowance (axial play) and the freeplay angle (torsion of the secondary flywheel against the primary flywheel until the tension of the spring can be felt).



5/15.5/16.5/1.6' 3100g

SAC Clutch alignment tool kit

929G2

NEW



- This kit allows the professional dismounting and mounting of all self-adjusting clutches (SAC).
- During assembling and disassembling operations the pre-tightening of the pressure plate is required in order to avoid clutch deformations.
- The 6-arms plate has been designed for use with 3 and 4 fixing points, for clutches with 6 or 8 locking holes.
- Application: VW, Audi, BMW, Ford, Mercedes-Benz, Renault, Vauxhall/Opel, Volvo...etc.



2/19.5/20.5/1.2' 9343g

17pc Clutch alignment tool set

917T2



- Essential for clutch installation on almost all cars and light-duty trucks. Align clutch plate properly by using tapered cones and pilot adapters.
- Includes seven fractional pilot adapters, one clutch disc centering adapter and one alignment shaft.
- Includes five metric pilot adapters, two clutch disc centering adapters and one alignment shaft.
- Size: 12/12.5, 14/15, 15.5/16, 17/18, 19/20, 15, 16.5, 17, 19, 20, 20.5, 25



12/15.5/16.5/1.4' 1290g

Universal clutch aligning tool

903T6

NEW



- Special design aligns and assembles clutch on the workbench for easy installation.
- Suitable for front wheel drivers that have no pilot bearing in flywheel.
- Designed for most vehicles up to 5 tons with single-plate clutches.



48/9/10/2.8' 143g

Clutch centering disc

902G25

NEW



- For the clutch disc mounted within the fly wheel.
- Adjustment is not possible without this tool, since the outer diameter of the centering disc is decisive.
- Application range: Volkswagen, Audi, Seat and Skoda engines.

Clutch centering mandrel tool

902G26

NEW



- For fast and exact clutch plate centering on vehicles with clutch guide bearing.
- For passenger cars and small commercial vehicles
- Adjustable from 15-19mm and 20-26.6mm.



Serpentine belt service tool set

913T1



- Combines the patented innovation of gear wrench with the requirements of the serpentine belt removal tool to provide the user with the best possible combination.
- Provides coverage for all major vehicles with serpentine belt configuration.
- The versatility and strength of the Gear Wrench allows for unlimited access to serpentine pulley tension arms with added attachments for unlimited coverage.
- Size: 8, 12, 13, 14, 17, 18, 24mm, 5/8", 3/8", 1/2"

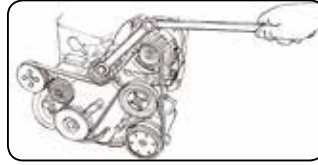

12/19.6/21.0/1.4' 1633g

Belt tensioning adjuster

9G0802



- For GM OPEL engines. Overcomes difficult access.
- Provides high torque without tilt or slip.
- Size: 41mm
- 1.2, 1.3, 1.4, 1.6, 1.6D, 1.8 ('87 onwards).

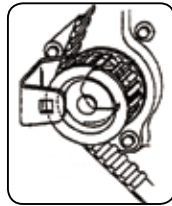

48/13.9/14.9/2' 280g

Belt tensioning adjuster

9G0803



- For GM OPEL engines. Overcomes difficult access.
- Provides high torque without tilt or slip.
- Size: 46mm
- 1.6(Up to '87), 1.7D, 1.8(Up to '87), 2.0.

48/13.9/14.9/2' 280g

Engine timing tensioner kit

908G6



- This set can use for ALFA ROMEO, FIAT, CITROEN, PEUGEOT, RENAULT, VOLKSWAGEN.
- A comprehensive range of tension lever and wrenches required for changing the cam belt on most popular petrol and diesel engines.

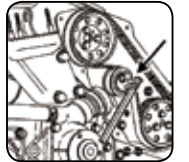

10/14.0/15.0/1.2' 1330g

Adjusting tensioner belt set

903G15



- Application: all VAG group.



36/24.7/25.7/1.5' 670g

Belt tension locking pins VW / AUDI / TDi PD engines

903G8

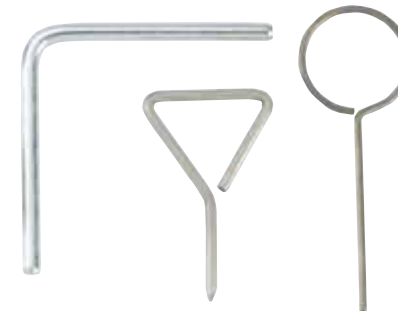

- Timing belt tension PINS-OEM NOS T10115, T40011 AND serpentine tension PIN-T10060/A
- For use on: LUPO. POLO 1.4 TDi PD
GOLF, BORA, POLO 1.9 TDi PD
BEETLE, SHARAN 1.9 TDi PD
PASSAT 1.9 TDi PD
AUDI A2/A3 1.4/1.9 TDi PD
A4/A6 1.9 TDi PD
A4/A6/A8/ALLROAD 2.5 V6 TDi



16g

■ Tensioner adjusting tool

902G4



- A set of two cam belt tensioner locking tools.
- Required for use on VOLKSWAGEN 4 cylinder TDI/ PD/ SOHC diesel engines.
- Including:
GOLF /GOLF PLUS/ JUTTA/ PASSAT/
EOS TOURAN/ CADDY /CADDY MAXI.



📦 120/13.2/14.2/1' ⚖️ 110g

■ PORSCHE Pneumatic chain tensioner

9G0809

NEW

- To adjust tension of chain by pneumatic.
- To adjust chain of V8 engine.
- Applicable: PORSCHE cayenne V8 4.5L, 4.8L AUDI Q7 .



📦 30/20.3/21.3/0.66' ⚖️ 676g

■ Belt tool kit for elastic- ribbed belts

902G9

- Suitable for engines with elastic ribbed belts such as Alfa Romeo, BMW, Chrysler, Fiat, Ford, Mercedes, PSA, Seat, Skoda, Smart, Volvo, VW-Audi...etc
- This tool set provides quick easy removal and installation of the new elastic ribbed belts required.



📦 30/17.0/18.0/1.3' ⚖️ 567g

■ 3pcs Belt installing tool set

903G20



- Specially designed set of tools for installing the new belt onto the pulley.
- Applicable: Ford, Mazda, Volvo, BMW, Chrysler, Citroen, Fiat, Lancia, and so on.



📦 100/19.0/20.0/2.2' ⚖️ 190g

■ Stretch belt remover/installer

9G0808

NEW

- Unique magnetic faces hold the tool in place on the pulley.
- Helps prevent damage to belt or pulley during removal or installation.
- Compact, one-piece tool can be used on the front or back side of the pulley.



📦 200/20/21/1.3' ⚖️ 189g



REMOVE



INSTALL

■ Universal tensioning gauge for cam belts

9G0804

- This tensioning gauge can be used to adjust the tension on the cam belts where the movement of the timing belt is measured by load.
- Suitable for use on cam belts with various belt thickness.
- Easy to use.
- Clear incremental marking with knurled knob for precise measurement.
- Dual scale allows reading from top or bottom of tool. (large and small numbers for compatibility)



📦 48/20.6/21.6/2' ⚖️ 338.5g

■ Universal Engine Belt Tension Tester

9G0609



- This tool can be used to confirm tension on the engine belt of cars.
- Simple to check the belt for proper tension.
- Suitable for all common types of engine belt. Including timing.ribbed.tooth and V-belt.



40/10.5/11.5/0.9' 250g

■ 9pc Hose clamp pliers kit

909G3



Contents:

- Hose clamp pliers
- 2pc Swivel jaw hose clamp pliers
- Angled flat bank hose clamp pliers
- Flat bank hose clamp pliers
- Clic-r collar pliers
- Hose remover pliers
- Screwdriver
- Hose remover



6/15.9/16.9/3.0' 2650g

■ 9pc Hose clamp pliers kit

909G9

NEW



Contents :

- 1pc Universal hose clamp pliers
- 1pc CLIC-R Collar pliers
- 1pc 3/8" DR. Hose clip to
- 2pc Hose remover set
- 1pc Slotted anti-slip screwdriver 1.2x6.5x25
- 3pc 1/4" DR. 6pt. Flank socket 6mm, 7mm 8mm

■ Flat band hose clamp pliers

62518



- Removes and installs new style flat band hose clamps.
- Jaws rotate to grip at any angle.



72/18.0/19.0/2.6' 250g

■ Angled flat band hose clamp pliers

62522



Designed to remove and install flat band hose clamps in hard-to-reach areas. Pliers feature angled jaws with rotating tips to grip clamps at any angle. Locking latch securely holds clamp in position.



48/10.9/11.9/2.7' 227g

■ Hose clamp pliers

62530



- For the operation of spring band hose clamps whose three ends are located on tubes, e.g. on fuel lines and tank ventilation lines on VW, AUDI, SEAT, SKODA



72/14.5/15.5/2.8' 201g

Flexible hose clamp remover

9G0201



- For replacement of fuel, oil and water hose.
- Hose clamp with flexible 630mm wire.
- Convenient for working hidden areas and long distance.



36/22.6/23.6/3.5' 630g

Hose clamp pliers (for VW, AUDI 2.0)

9G0208



- Special jaw design for VW, AUDI 2.0 TDI engine lower water hose clamp.
- Max clamp capacity: 55mm.
- Flexible 630mm cable enables user to reach, remove and lock clamp into the open position.



24/20.5/21.5/2.3' 854g

Universal hose clamp pliers

9G0126

NEW



- Special angled jaws designed for most kinds of hose clamps.
- Finger tip "position lock" to keep hose clamp spreading open.
- Capacity: 0mm ~ 65mm

24/10.5/11.5/2' 416g

Hose clamp pliers

62528



Deep-slotted Jaws can remove and replace all size spring wire hose clamps and lock them safely in an position.



Part no.	<i>l</i> mm	packing	g
6252807	180	40/14.7/15.7/1.5'	370
6252809	230	30/12.5/13.5/0.82'	415

Hose clamp pliers (angle type)

9G0109



- Designed with angle type to any space.
- Swivel tip designed for refitting and release.
- For CLIC and CLIC-R type hose clamp.



40/11.4/12.4/2.4' 285g

CLIC-R Collar pliers

9G0104



- For releasing and refitting reusable hose clips.
- For type CLIC and CLIC-R.



48/12.6/13.6/1.9' 260g

Hose clip pliers

9G0117



- For fitting 1-lug or 2-lug hose clips.
- The special arrangement of the jaw allow, the clips to be closed either at the end or at the side, depending on the accessibility of the working area.
- Size: 230 mm



36/15.1/16.1/1.2' 419g

3/8" DR. Hose clip tool

9G0120



- Designed to fix the hose without removing sensors, duct, hose...etc. that are near the hose clamps.
- The end shape with trapezoidal teeth does not slip and allows various positions. (vertical, horizontal, diagonal...)
- Suits difficult work with pliers type tool of vehicle type.



10/16/17/1.6' 190g

■ **2pc Hose remover set**

902G22



- Allows the mechanic to easily free stuck or adhered automotive hoses without fear of hose damage or personal injury.
- Perfect for use on coolant, vacuum, oil and power steering hoses of all diameters.

72/16/17/3.4' 222g

■ **Hose removal pliers**

9G0105



For easy removal of 5/32" to 1/2" vacuum and fuel hoses.



72/14.5/15.5/2.4' 200g

■ **Professional hose removal pliers**

9G0106



- For easy removal of 4mm to 21mm vacuum and fuel hoses.
- Special mini anti-slip jaw to avoid pipe slip and to make removal easy.

72/14.0/15.0/2.4' 194g

■ **Fluid hose clamp**

9G0110



Completely or partially closes flexible brake, fuel, and vacuum, fluid line. All steel construction with adjustable locking collar.



96/5.8/16.8/1.4' 165g

■ **Hose pinch-off tool (bar type)**

9G0111



- Suited for both brake and fuel lines.
- Effective pinch action with rounded clamp section to prevent damage to hose lining.



72/18.5/19.5/0.9' 257g

■ **4pc Fluid line clamp set**

904G8



- Conveniently pinch off fuel, vacuum, transmission, brake, heater lines and more.
- Sizes: 3/8" (~Ø10mm), 1/2" (~Ø15mm), 1" (~Ø25mm) & 1-3/4" (~Ø45mm)



24/12.0/13.0/1.2' 470g

■ **3pc Hose pinch-off pliers (8", 10" & 12")**

9G0112



- The pinch-off pliers act as a third hand to help you keep hose changed tightly when you are servicing various engine components.
- No need to drain cooling system when changing thermostats and thus can save coolant and time.
- Jaws swivel for parallel clamping.
- Locking ratchet provides tight grip in just about any position.
- Can also be used to pinch-off many other hoses.
- Do not use on wire reinforced radiator hose.



18/22.5/23.5/1.9' 1.25kg

Part no.	l inch
9G0112A	8
9G0112B	10
9G0112C	12

■ **Locking pinch-off pliers 280mmL**

9G0115



- Pinch off and lock on butane gas lines and copper tubing.



36/17.1/18.1/1.5' 475g

3pc Hose pinching pliers

903G12



- Smooth, rounded jaw, edged prevent damage to internal hose reinforcement.
- Quick and simple, one handed use.

Size:
Hose clamp for up to 10mm, 15mm, 24mm line diameter



60/18/19/3.6' 300g

3pc Hose clamp gripper set 90°

903G18



- Made of heat resistant nylon.
- Rounded jaw edges prevent damage to internal hose reinforcement.
- Features locking mechanism for simple one-handed use.
- Suitable for brake, coolant, fuel & vacuum hoses.



24/9.0/10.0/2.4' 375g

Viscous fan hub spanner

9G0710



For removal of thermo, viscous fan hubs. cranked for easy access.

Size: 32mm
BMW 316, 520i, 525i, 530i, 535i, 730i, & 735i.
FORD CAPRI, SIERRA, GRANADA 2.0 & 2.8.
FORD TRANSIT 2.0 1986-90 (with viscous fan)
LCX 2.0, LCT 2.0, 2.5 Diesel 1980-90,
LCX 2.5D & LCY 2.5D.



36/21.4/24.5/1.2' 595g

Viscous fan hub spanner

9G0710A



For removal of thermo, viscous fan hubs. cranked for easy access.

Size: 36mm
FORD GRANADA 2.4 & 2.9.
GM CARLTON MANTA & SENATOR.

36/21.4/24.5/2.5' 595g

Radiator cap wrench

9U0702



- Quickly and safely removes all standard radiator caps.
- Engage the wrench over the cap and then press down and turn. Easy!

Warning:

1. Do not open cap if radiator is hot. Hot fluid can erupt and cause burns.
2. Always wear ANSI approved safety goggles when working with tools and equipment.



48/18.2/19.2/3.3' 380g

Battery / anti-freeze cleaning fluid tester

9G0303



- Testing range: Ethylene Glycol: -50 ~ 0 °C
Propylene Glycol: -50 ~ 0 °C
Battery Fluid: 1.100 ~ 1.400 sg
Cleaner: -40 ~ 0 °C
AdBlue: 30 ~ 40 %

40/16.0/18.0/1.8' 400g

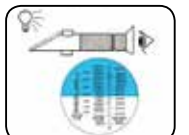
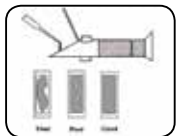
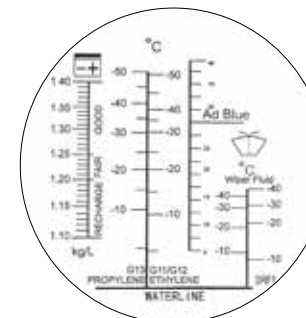

■ Anti-freeze tester

9G4001



- Avoid winter freeze-ups and summer boil-over.
- Test all permanent (Ethylene Glycol) solutions with radiator hot or cold.
- Two scales show freeze point of radiator solution and boiling point of summer coolant.



100/13/15.2/5.8' 130g

■ Cooling system vacuum purge & refill kit

906G2



- Designed to pump radiator and cooling system to vacuum.
- Simply refill coolant into radiator without air.
- Gauge: 0~76 cm-Hg, 0~30 in-Hg

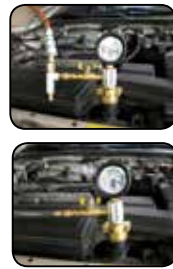

10/15.0/16.5/3.05' 1400g

■ Cylinder leakage tester

905G10



- This set could test if the wall of cylinder is abrasive.
- The CO2 test liquid is checking volume of CO2 existing in radiator in the car.
- Have blue color of test liquid mixed with stem in the radiator if the liquid become yellow or green then it means that the wall of cylinder is abrasive.
- It offers simple, quick and correct test.
- The CO2 test liquid is recyclable.



10/13.5/14.5/3.05' 1200g

■ Cylinder leakage tester

907G8



- This tester kit is used for checking the radiator to see if any water leaked because of the body or the connector not fitted properly or any broken.
- It's tested through pressure increase by using an adapter for closing the master or second inlet of the radiator then pushing the manual pump by hand.
- Applicable: Mercedes, GM (Buick), Jeep, Peugeot, Subaru, Chrysler, Acura, GM (Nova, Spectrum, Sprint), Mitsubishi, Nissan, Mazda, Toyota, Infiniti, Geo, Suzuki, Isuzu, Ford, Honda.
- Gauge: 0~35 PSI, 25 bar



4/8.8/9.8/2.16' 2200g

■ Cooling system & radiator cap pressure tester

908G2



- Designed to test radiator cap relief pressure and seal condition.
- For use with most vehicle radiators, includes hand pump with gauge, universal cooling system adapters, radiator cap adapters.
- Applicable: Mercedes, GM, Jeep, Peugeot, Chrysler, Acura, Mitsubishi, Nissan, Mazda, Toyota, Infiniti, Geo, Suzuki, Isuzu, Ford, Honda.
- Gauge: 0~35 PSI, 25 bar



5/17.5/18.5/2.3' 2.9kg

■ Universal radiator pressure tester kit

914G1



- Designed to test the leaks of cooling system.
- Suit for: Suzuki, Isuzu, Lexus, Opel, Peugeot, Jeep, Rover, Citroen, Nissan, Mitsubishi, Mazda, Subaru, BMW, Renault, Fiat, Alfa Romeo, Toyota, Honda, Ford, GM, Chrysler, VW, Audi, Volvo, Saab, Mercedes Benz, Infiniti, Geo, Truck.
- Gauge: 0~35 PSI, 25 bar



4/15.5/16.5/2.9' 3875g

■ Cooling system & Radiator cap pressure tester

922G1



- For use with most vehicle radiators, includes hand pump with gauge, universal cooling system adapters, radiator cap adapters.
- Applicable: Mercedes, GM 4 Cylinder (Buick, Chevrolet, Oldsmobile, Pontiac, Cadillac), Jeep, Peugeot, Chrysler, Acura, GM (Nova, Spectrum, Sprint), Mitsubishi, Nissan, Mazda, Toyota, Infiniti, Geo, Suzuki, Isuzu, Ford, Honda, VW, Audi, Opel, Saab, Volvo, Lexus, BMW, Jaguar.
- Gauge: 0~35 PSI, 25 bar

3/15.9/16.9/2.4' 5.3kg

■ Universal multi-purpose cooling system test kit

919G3



- Kit provides major tests in the cooling system: Pressure test (leaking test), temperature sensor test, water pump, thermostat and cooling fan condition tests.
- Suitable for universal vehicles.
- Including step adapters and hose clamps of various sizes, suitable universal application.
- Including a high-quality displaying device: (e.g. digital LCD, glass screen and a gauge), helping mechanics detect potential problems in cooling system.
- Targeted tests can be operated individually.



2/8.5/9.5/2' 4.25kg

■ Image guide scope

9G2203



- Inspects hard-to-reach corners with 18", diameter 4mm flexible cable for easy operations.
- Equipped with illumination lamp for clear viewing.
- Optional 35°, 45° and 60° mirrors are available.

- Optional mirrors:
9G2203-35 (35°)
9G2203-45 (45°)
9G2203-60 (60°)

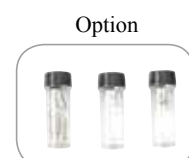

5/10.0/11.0/2.3' 2Kg

■ Mechanic's stethoscope

9G2204



- Provides a fast and easy way to locate noises in engines or bearings and other moving parts.
- Ideal for pinpointing unusual vibrations or suspected leaks (valves, piston rings, gaskets etc.)

40/9.5/10.5/2.7' 200g

■ Mechanic's stethoscope

9G2201



- Provides a fast and easy way to locate noises in engines or bearings and other moving parts.
- Plastic earphones shut off outside noises.
- Aluminum alloy probe/needle for finding the exact location of specific noises.
- High quality surgical PVC & rubber parts for increased sound definition.
- Instrument is shockproof.
- Ideal for pinpointing unusual vibrations or suspected leaks (valves, piston rings, gaskets etc.)
- Supplied with a rubber trumpet for checking vacuum & pressure flow.
- Useful for synchronizing multi carburetors.

48/9.6/11.0/4.4' 200g

■ Automotive noise finder

902G11



- This is a portable automotive noise finder which can quickly detect source or location of noises emanated from bearing, gear, valve, valve body, crankshaft, cylinder, gearbox, car body and so on after starting engine.
- It helps the serviceman to pinpoint the actual noise part and severity even in severe ambient noise.

40/9.0/10.0/3.1' 225g

■ Combination electronic stethoscope kit

9G2202



- To locate & identify noise and enable road test diagnosis.
- Super sensitive microphone pick up.
- Defect & isolate noisy components.
- Contents: Flexible non-conductive shaft
Cushioned headphones
4 channel sensor selector unit
4 pick up sensors-4.8mm ling cords



6/16.0/17.0/4' 2670g

■ Vacuum pump / Brake bleeding kit

906G3



- Check vacuum operated components on cars and trucks.
- Allows you to bleed brake fluid without the mess.

Contents:

1. Vacuum pump (0~30 in.Hg)
2. Connection hose. (600mm x 2 pcs)
3. 200ml fluid reservoir bottle.
4. Fluid transfer and storage lids x 2 pcs.
5. Connection accessories:
(Rubber cupped adapter)
(Accessory hoses: 75mm x 2 pcs)
(Accessory hoses: 95mm x 2 pcs)



5/7.8/8.8/2.5' 1830g

■ Vacuum testing / Brake bleeding kit

908G8



- The kit includes the vacuum pump, complete fittings and accessories for vacuum testing and brake bleeding, plus a detailed owner manual. The vacuum pump is field repairable. Re-place worn O-rings, seals and valves with the vacuum pump repair kit
- Pressure range: 0 ~ 60 PSI / -30 ~ 0 PSI

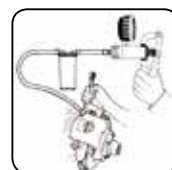

6/11.0/12.0/2.4' 1.8kg

■ Turbo system tester kit

909G7



- For fast diagnostics of the air charging.
- Enables time-saving and appropriate determination of leaky intercoolers and invisible cracks in air charging hose.
- Four pairs of stepped adapters : 85 - 90, 75 - 80, 65 - 70, 55 - 60 mm



5/18/19/2.5' 3600g

■ Turbo system pressure tester kit for commercial vehicles

907G19



- For fast diagnostics of the air charging.
- Enables time-saving and appropriate determination of leaky intercoolers and invisible cracks in air charging hose.
- Three pairs of stepped adapters : 105-110, 115-120, 125-130



■ Gas cylinder compression tester set

908G1



Gauge: 0~300 PSI, 0~21 kg/cm²

Contents:

Air gauge with quick coupling & release valve. High-tension connecting pipe with safety lock coupling. Crank shaft type test pipe with rubber plug. Transverse axis test pipe with rubber plug.
M10*1.0 Adapter
M12*1.25 Adapter
M14*1.25 Adapter
M18*1.5 Adapter

10/11.6/12.6/1.26' 1160g

■ Petrol engine compression tester set

909G1



- Gauge: 0~300 PSI, 0~21 kg/cm², 20 bar
- Comprehensive kit based on petrol compression tester for vehicles with M10, M12, M14 and M18 spark plug threads. Complete with extensions (M10, M12, M14, M18), thread chasers (M14&M18, M10&M12) and service kit.



- Checks condition of valves, piston rings, gaskets & cylinder heads.
- Used on cars, vans & motorcycles.
- Pressure relief valve enables repeated testing of a cylinder without removing the gauge.

8/13.5/14.5/2' 1688g

Oil pressure tester set

912G1



- Helps to diagnose worn oil pumps and engines, faulty oil pressure switches and warning indicators.
- Accurately tests oil pump pressure, switch & warning indicators.
- Large clear dual scaled gauge.
- Quick coupling adapters, with shut-off valve, for speed & security.
- Permanently oil primed, long, flexible hose.
- Gauge: Scale: 0~150 PSI, 0~10 kg/cm², 0~10 bar
Thread: R/18 Din 2999, 1/8 x 27 Npt, 1/4 x 18 Npt, 3/8x 20 Unf, 1/2 x 20 Unf, M10 x10, M12 x1.5, M14 x1.5, M16x 1.5, M18 x1.5, 90°Elbow

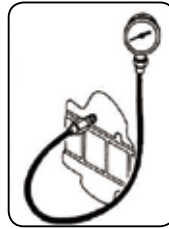

6/11.0/12.0/2.3' 1830g

Power steering tester

915G5



- For accurate, reliable power steering analysis.
- Determines if trouble is in front of suspension or steering linkage.
- Saves valuable time when rebuilding or replacing parts not actually defective.
- Set contains 2,000 PSI gauge with metering valve, connection hose, 13 adapters and power steering pressure specifications.
- All packed in a plastic storage case.
- Applications: American Motors, Chrysler Corp, Ford Motor.

6/9.0/10.0/1.5' 1500g

Transmission pressure gauge set

922G6



- For all major manufacturer domestic and import vehicles.
- Contains two gauge assemblies for high and low pressure ranges.
- Nine adaptors to test a wide variety of domestic and import automatic transmissions.
- Four special fittings are also included for connection to hard-to-reach test ports in areas requiring a 45° or 90° angle.
- Applications: Acura/Honda, BMW, Chrysler Corp, AMC/Eagle, Jeep, Ford, General Motors, Saturn, Hyundai, Infiniti, Isuzu, Jaguar, Lexus, Mazda, Mercedes, Mitsubishi, Nissan, Peufoot, Saab, Subaru, Suzuki, Toyota, VW, Volvo.

5/10.0/11.0/1.5' 2000g

Gasoline engine injecting pressure tester set

946G1



- Gauge: 0~120 PSI 8 bar
- This tester is an assembly of fuel injection pressure test.
- The related adaptors are suitable for cars of American, Japanese and European systems.



4/20.7/21.7/4' 5180g

11pc Deluxe noid lite / IAC test kit plus one fibre optic noid lite extension

88442



- Set includes eight noid lights for testing GM PFI, FORD TBI, GEO TBI, BOSCH PFI, GM TBI, GM SCPI, GM MULTEC 2, BOSCH 2.
- One IAC signal test lights for GM1982 or newer GM TBI and PFI fuel injection system, and one for GM Model 1987 or newer GM Model 700 TBI and PFI fuel injection system, Plus one fibre optic Noid Lite extension.
- Kit Comes in a deluxe molded plastic case.



24/11/12/2' 442g

Fuel injection cleaner & tester kit

940G1



- Universal for all cars
- Cleaning fuel injector
- Cleaning intake valve
- Cleaning combustion chamber
- Cleaning vacuum system
- Cleaning parts and valves
- Test engine system pressure
- Test fuel pump pressure
- Test the sealing condition of return line diaphragm



4/19.2/20.2/2.9' 4.8kg

Carburetor synchronize tool set

919G2



- For testing fuel pump carburetor and transmission check auto with 2~4pc carburetors.
- Gauge: Pressure: 0~15 PSI, 0~1 kg/cm²
Vocuum: 0~28 in-Hg (0~70 cm-Hg)



Contents:

- 4 pc 3-1/2" Synchronizer gauges with fixed plate
- 4pc Rubber hose 8 X 5 X 750mm
- 4pc Extension tube 3.9 X 52mm
- 4pc Extension tube 3.9 X 122mm
- 8pc Cone type connector 8 X 40mm
- 4pc Adapters 10 X 53mm (M6 X 0.75)
- 4pc Adapters 10 X 60mm (M6 X 1.0)

6/20.0/21.0/2.25' 3.33Kg

Professional vacuum & fuel tester set

904G4



- Large 3-1/2" diameter gauge with color-coded easy-reading scales.
- Extra long heavy-duty rubber hose and 14mm/18mm.
- Checks for worn or defective parts in fuel pumps, vacuum system.
- Gauge: Pressure: 0~15 PSI, 0~1 kg/cm²
Vocuum: 0~28 in-Hg (0~70 cm-Hg)

20/13.0/14.0/1.85' 650g

Cylinder leakage tester

902G3



- PSI&BAR percentage gauge
- 26" extra long hose
- Allow you to accurately diagnose engine problems such as bad valves, worn rings.
- Cracked cylinder walls and blown gaskets.
- Works from shop airline and has 14&18mm adaptor fittings to fit most engines.
- Blow-by readings shown in percentages.
- Dual gauges allow mechanic to monitor input line pressure.
- Supplied in plastic blow mold case.
- Gauge: 0~100 PSI 7 bar



10/11.0/11.5/1.4' 1.1kg

Transmission & engine oil pressure tester

912G2



- Designed to check engine oil pressure in automatic transmissions and engines in both cars and trucks.
- With two easy to read dual scale gauges. Both of two gauges with quick set-up. Complete with 6ft(1.8m) of oil proof hose, nine adaptor fittings, and instructions.

- Dual gauge readings:
A: 0 to 400psi (0 to 28bar)
B: 0 to 150psi (0 to 10bar)

- Gauge diameter: 2.5"

10/14.0/14.5/1.4' 1.4kg



Diesel engine compression tester set (cars)

913G1



- Comprehensive test kit for both direct and indirect diesel injected cars.
- For use on both direct or indirect injection engines.
- Checks engine compression under cranking conditions.
- Small profile, quick coupling adapters for speed & security.
- Built-in pressure relief valve enables repeat tests without dismantling.
- Flexible hose (355mm) gives access to restricted plug & injector ports.
- Dual scale 80mm Dia gauge 0-1000 PSI & 0-70 bar.

6/16.3/17.3/2' 2720g

Diesel engine compression tester set

914G3



- Comprehensive kit for checking compression on both direct and indirect diesel-injected commercial, marine and industrial engines.
- For commercial, marine & industrial engines.
- Checks engine compression when cranking.
- For use on direct or indirect fuel injection engines.
- Built-in pressure release enables complete tests without dismantling.
- Small-profile, quick-release coupling system.
- Dual scale 80mm dia. gauge 0-1000 PSI & 0-70 bar.
- Flexible hose (355mm) to give access in restricted spaces.

4/20.7/21.7/3.7' 5180g

■ Diesel compression tester

916G2



- 2-1/2" dial, glycerin filled gauge with glass lens in stainless steel housing 4,500 psi rated nylon jacketed pressure hose assembly.
- Dual scale 0-1,000 psip; Metric scale 0-70 bar. 13 piece adapter set (Deere & BMW adapters included)

3/15.9/16.9/1.5' 5300g

■ Diesel engine compression test set

937G1

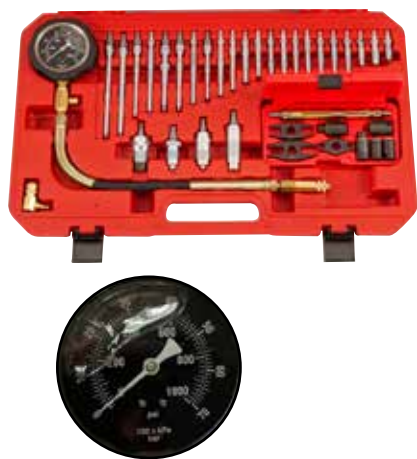

- Features 600psi (40bar) gauge with large rubber bumper, straight and right angled quick-connect fittings and an extensive range of glow plug and injector adaptors.
- This kit will cover most modern car, van, truck, bus, agricultural and marine engines.
- Glow plug adaptors: Wide range of Alfa, BMW, Chrysler, Daewoo, Fiat, Ford, Hyundai, Isuzu, Land Rover, LDV, Mazda, Mercedes, Mitsubishi, Nissan, Opel, PSA, Renault, Saab, Suzuki, Toyota, VAG, Vauxhall, Volvo diesel engines.
- Injector Adaptors: M20, M22, M24 & Ford Stanadyne Injectors plus Clamp-On Injectors..

4/20/21/2.4' 500g

■ Diesel engine cylinder leakage test kits

938G1



- Three diesel engine cylinder leakage test kits that cover the wide range of modern engines ,including HDi, TDCi and Pompe Duse .
- This kit covers most popular cars and vans, it has additional glow plug adaptors for increased coverage and with any further, and includes adaptor set for clamp-type injectors to give even wider coverage of car, van, truck and bus, agricultural and marine applications.
- Glow plug Adaptor:Wide range of Alfa , BMW , Chrysler , Daewoo , Fita , Ford , Hyundai , Isuzu , LandRover , LDV , Mazda , Mercedes , Mitsubishi , Nissan , Opel , PSA , Renault , Saab , Suzuki , Toyota , VAG , Vauxhall , Volvo diesel engines
- Injector:M20 , M22 , M24 & Ford Stanadyne injector plus clamp-on injector

■ Common rail injector, return flow pressure measurement tester

912G8



- For testing the return flow pressure from common rail injectors of Bosch, VDO/Siemens & Delphi engine system. Suitable for testing the condition of a piezo pass or fail statement.

10/12.6/13.6/1.9' 1260g

■ Return Fuel Volume Tester for Common Rail Injectors

902G8



- Designed for checking the amount of fuel that every injector returns to the tank to find out the damaged injector.
- Can simulate 6 injectors at the same time.

10/18.0/19.0/1.5' 1.8kg



■ 4pcs Injection nozzle socket

904G13



- Remove top cap and connector before removing diesel fuel injector.
- Deep and wide configuration.
- Fits virtually all standard injectors for recent motor vehicles.
- 1/2" Dr. Socket can use for Siemens & Bosch injectors.
- Suitable for Peugeot and Citroen with 2.0 engines (110/135HP) HDI engine.
- Sizes: 25, 27, 29, 30mm.
- Length:100 mm

10/15.0/16.0/1.2' 1488g



4pc Diesel injector socket set

904G3

For use on: ALFA ROMEO, CHRYSLER, BMW, FORD, VW, MERCEDES, AUDI, OPEL, VAUXHALL, SEAT, VOLVO, ROVER also on VOLVO, MAN2.5TD & SCANIA HGVS.



Size	Description	Length
22mm	injector socket (6 pt)	110mm
22mm	injector socket (12 pt)	75mm
27mm	injector socket (12 pt)	78mm
28mm	injector socket (12pt)	78mm

10/11.4/12.4/0.8' 1.14Kg

Diesel injector puller

9G0114

- Assists removal of stubborn BOSCH and LUCAS diesel injectors, saving time and money when injectors are difficult to remove.
- With M8 /M12 / M14 adaptors
- Applicable: VOLVO, SCANIA



40/16.0/18.0/1.8' 400g

Diesel injector nozzle extractor set

903G19

- Extraction injectors without dismantling the engine.
- Extraction Bosch injectors.
- For CDI engines 2.1 l and 2.2 l.
- Application: Vito, Sprinter, Viano, C and E Class, CLC, CLK.



6/16/17/1.8' 2580g

Diesel injector nozzle extractor set (PSA HDI engines)

910G3

- Common Rail Injector removal tool set for removal of seized Injectors on Peugeot, Citroen, Suzuki diesel HDI engines.
- Pulling bridge that fits perfectly on PSA cylinder head.
- Special screw system that allows a fast and easy nozzles removal.
- Applicable Engines: PSA 2.0 & 2.2 HDI (110, 135 PS), HDI DW10 and DW12 engines .



6/22.0/23.0/1.4' 3660g

Diesel injectors remover tool - model FOSI

926G1

- For the extraction of extremely seized injectors.
- With the precisely tailored specification for this job.
- Application designed extractor, the injectors can be extracted hydraulically or mechanically.
- Application: Fiat , Lancia , Alfa , Opel , Suzuki , Ford , Iveco , PSA.



2/23.0/24.0/1.05' 11500g

Diesel injectors remover for BMW

908G11

- Complete set for removing BMW CR injectors without dismantling the cylinder head.
- Equipped with a blower adapter to clean the injector seats.
- Bosch injectors: common rail injectors mounted on BMW
- Application: BMW Common Rail : M47TU, M57, M57TU.



2/13.0/13.8/0.9' 6500g

■ Diesel injectors remover for JTD

9G0119



- Universal injector remover with 4 adjustable feet for JTD diesel engines.
- Remover for common rail injectors.
- Application: FIAT, ALFA, OPEL, SAAB, SUZUKI.

8/19.0/20.0/1.8' 2375g

■ Diesel injector remover - hydraulic kit

909G8



NEW

- Turns all diesel injector removers into hydraulic kit.
- This set enables the controlled extraction very tight-fitting or stuck injector nozzles.
- It is used in conjunction with a injector nozzles puller with extraction bridge, and a hydraulic pump.
- Hydraulic Cylinder 17t with shoulder nut M16x1.5



- Contents:
- Pull Spindle M14*1.5(240mm)
- Pull Spindle M14*1.5(315mm)
- Pull Spindle M17*1(240mm)
- Pull Spindle M17*1(315mm)
- Pull Spindle M18*1.5(315mm)
- Pull Spindle M25*1(240mm)
- Distance ring
- Tooth Cap Nut M16
- Bush

2/13.5/14.5/1.24' 6504g

■ Injector nozzle extractor with spindle

903G17



- This special-designed diesel injector puller set is ideal for the need to remove stubborn diesel injector.
- No need to remove cam cover and the use of slide hammer, either.
- Application: Mercedes C-Class, E-class, Sprinter Vehicles and Chrysler Grand Cherokee 27crd (00).



12/15.5/16.5/1.1' 1291g

■ Injector extractor with slide hammer for DB CDI-engines

909G5



- For removing stuck and the seized common-rail injectors without dismount the cylinder head.
- The sturdy construction will enable the swift removal of the most severely seized in injector.
- For Mercedes CDI engines OM 611,612,613 etc and DB CDI-engines.



- Specification: Total length: 350mmL
- Slide hammer: 1.75kgs
- Adaptor: M17x1
- Adaptor: M27x1.0 for Bosch injector nozzle.
- Adaptor: Puller w/M12x1.75P

6/20.0/21.0/1.5' 3333g

■ VW, AUDI Diesel & gas injection remover tool (TDI & FSI)

912G6



- Use "U" sleeve or two jaws hook to fix the injector and then pull out with slide hammer.
- Special two jaws design to fix the injector and pull out with slide hammer.
- Applicable range: VW, AUDI TDI, AUDI FSI, AUDI, SEAT, SKODA.



6/22.0/23.0/0.9' 3666g

■ 4pc Diesel injector removal set for Delphi & Bosch

904G9



- Specifically designed for removing Delphi/Bosch diesel injectors using a Slide Hammer with 5/8" UNF thread.
- Adaptors can also be used with an air tool to loosen the injectors by vibration.
- Set of 3 adaptors plus a special tool for removing the internal part of Bosch injectors.

18/18.5/19.0/1.0' 1027g

33 Teeth socket diesel injection pump for Mercedes

9G0121



- Multipoint socket for installing and removing the pressure valve holder on the MRSF-ERE fuel injection pump.
- Applications: Mercedes-Benz-diesel engines 601, 602, 603, 605, 606, 615, 616, 617
- Size: 1/2" DR. x 33 teeth



100/14.0/15.0/1.2' 83g

Diesel pre-chamber collar nut socket for Mercedes

9G0122



- Spline socket for pre-chamber repair of all diesel engines since 1989.
- Mercedes Diesel Engines 601, 602, 602.91, 603, 604, 605, 606, 661, 662
- Size: 1/2" DR. x 58 teeth



50/15.0/16.0/1.0' 223g

Diesel fuel filter socket (HDi engines)

9G0123



- Specialist socket required for the removal of diesel fuel filter fitted to 2.0, 2.2 HDi engines.
- Applications: Citroën: C4 2.0 HDi 16v, C4 Picasso 2.0/2.2 HDi, C5/ C8 2.0/2.2 HDi 16V, Jumpy 2.0/ 2.2 HDi
Fiat: Scudo / Ulysse Mk II 2.0 JTD 16V
Ford: Focus/ Focus C-Max/Galaxy/Kuga/S-Max 2.0 TDCi
Peugeot: 307/308/407/607/807/Expert 2.0 HDi 16V
Volvo: C30/C70/S40 Mk II/V50 2.0 Diesel(136 HP)
- Size: 1/2" Dr x 27mm



100/13.0/14.0/0.6' 139g

Diesel injector copper washer removal tool

9G0118



- Collect type - easy to hold the copper washer.
- Size: Inner hole \varnothing 7mm
- Length: 230mm



20/16.0/17.0/1.2' 800g

Diesel injection pump puller (BMW)

904G7



Large: Pump remover & Sprocket retaining tool covers injection/HP pump removal on BMW models with M74/M47TU and M57/M57TU 2.0&3.0 diesel engines.

Small: Pump remover Sprocket retaining tool covers injection/HP pump removal on LAND ROVER FREELANDER and ROVER 75 model is with Td4 and M47 2.0 engines.

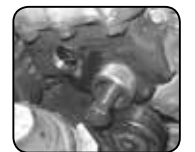
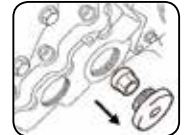

20/20.0/21.0/0.8' 980g

Diesel injection pump puller (BMW)

9G1501



- This tool is specifically designed for holding the sprocket/chain in place when disassembling the VP44 injection pump and high pressure pump.
- Common rail fitted to BMW engines:
318D/COMPACT(E46), 320D/TD COMPACT(46), 330D(E46)
525D(E39), 525D(E60/E61), 530D(E39), 530D(E60/E61),
535D(E60/E61), 730D(E38), X5 3.0D(E53)

20/11.0/12.0/0.5' 530g

■ Glow-plug connector pliers (Straight)

9G1001

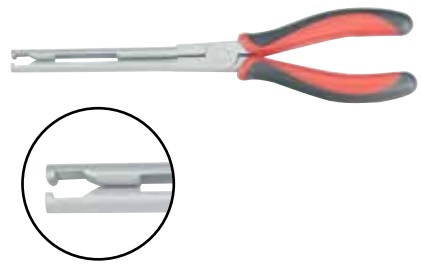

- Designed to remove hard-to-reach glow plug connectors, without damage on the latest diesel engines.
- Applicable: BENZ, BMW, VW, Audi... etc.

36/10.0/11.0/2.05' Δ 277g

■ Glow-plug connector pliers (Angled)

9G1002

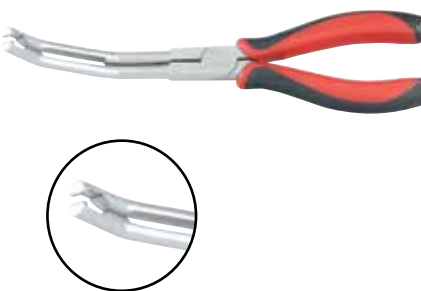

- Special angle designed to remove stubborn and hardly accessible glow plug connectors installed on the latest-generation engines.
- Applicable: BENZ, BMW, VW, Audi... etc.
- Version angled at 90°



36/10.0/11.0/1.19' Δ 277g

■ 1/4"DR. Glow plug impact socket set

909G6



- A torque air impact wrench set and designed for the diesel engine glow plugs which hard to removal.
- Special long-reach 8 mm, 9 mm 10 mm, 11 mm and 12 mm sockets for ease of access.
- Also includes: short and long extension, universal joint and special 1/4" air impact wrench.



6/11.1/12.1/1.4' Δ 1850g

■ 9pc Pre-heater plug tools

K909G4



- To ream out and clean the bore between the glow plug and pre-combustion chamber.
- Size: M12 x 1.25, M10, pre-heater plugs with 10mm across flats.
- Fasten the glow plug with the correct torque
- 1/4" DR. universal socket size: 8, 9, 10, 12 mm

Thread Diameter	Tightening Torque
8mm	8-15Nm(0.8-1.5Kgm)
9mm	15-20Nm(1.5-2.0Kgm)
10mm	15-20Nm(1.5-2.0Kgm)
12mm	20-25Nm(2.0-2.5Kgm)

6/9.9/10.9/0.8' Δ 1650g

■ 3pc Pre-heater plug puller set

903G16



- To ream out and clean the bore between the glow plug and pre-combustion chamber.
- Application : pre-heater plugs with 10mm, glow plug 6 and 7mm.



24/14.0/15.0/1.6' Δ 570g

■ Glow plug removal and puller set

916G3



- Simplifies the assembly and disassembly and professional repair of glow plug thread.
- Suitable for most injectors.
- Assembly and disassembly of glow plugs and repair glow plug threads.
- Extractor for fixed glow plugs.
- Step drill to drill out damaged glow plugs 7 x 5.5 mm and 9 x 5.5 mm.
- Taps M8 x 1.0, M10 x 1.0 and 1/4"-28UNF for repairing glow plug threads.
- Tap holder.
- E10 socket .



10/17.5/18.5/1.6' Δ 1750g

27pc Glow plug tool set

927G3



- Designed for removal of damaged/broken glow plugs from cylinder heads.
- Suitable for glow plugs with M8-M9-N10 thread.
- Set includes all required adaptors, centering and cleaning tools to safely remove glow plugs without damaging engines.



5/12.5/13.5/1.3' 2247g

33pc Glow plug thread repair set

933G1



- Designed to repair the threads of glow plugs .
- Tap size: M8 x1.0, M10 x1.0, M10 x1.25, M12 x1.0, M12 x1.25, M14 x1.25
- Thread coil size: M8 x1.0 (I) - M10 x1.0 (E), M10 x1.0 (I) - M12 x1.0 (E), M10 x1.25 (I) - M12 x1.25 (E), M12 x1.25(I) - M14 x1.25 (E)
- 2pcs Thread coil drivers.



10/17/18/1.5' 709g

Diesel injector seat cutter set

906G1



- This kit has been specially designed for the clean and re-cutting of injector seats on modern common rail diesel engines.
- The kit includes 4 seat cutting reamers for BOSCH, DELPHI and universal application along with a special angled reamer for IVECO/ FIAT applications.

36/20.0/21.0/1.2' 570g

Diesel injector seat cutter set

907G7



- This kit has been specially design for cleaning and re-cutting injector seats on modern common rail diesel engines.
- 15mm flat reamer for universal injector.
- 17mm flat reamer for DELPHI / BOSCH injectors (BMW / PSA / RENAULT / FORD)
- 19mm flat reamer for BOSCH injectors (MERCEDES CRD)
- 19mm angled reamer for FIAT / IVECO.
- T handle, Pilot post

20/19.2/19.7/2' 950g

Injector sealing seat cleaning & milling set

921G2



- This is the optimized version of the cleaning and milling tool set.
- The advantages are clearly obvious.
- Can be used with HDI engines, diesel direct injection and common rail engines with BOSCH and DELPHI injectors.
- Shaft cleaning by brushes with machine drive, sealing seat cleaning with cutter 120° Ø21mm; 17mm stepped, miller 0° Ø17mm continuous, miller 0° Ø19mm; 17.0mm; 15.0mm stepped.



10/17/18/2.5' 1700g

Valve spring compressor

62101



- For large engines, most suitable for commercial vehicles and general garage use.
- Jaw opening 70-200mm, Throat clearance 250mm.



8/26.4/27.4/1.7' 3.3Kg

■ Valve spring compressor

62102



- For overhead cam engines, specially designed for O.H.C. engines.
- Jaw opening 60-155mm, Throat clearance 150mm.



12/19.6/20.6/1' Δ 1630g

■ Valve spring compressor

62103

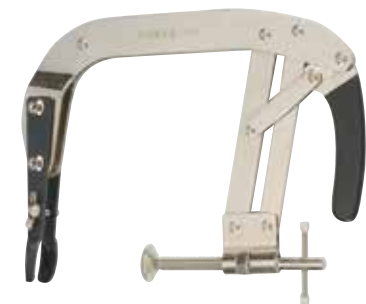

- For small and medium engines.
- Jaw opening 68-130mm, Throat clearance 150mm.



10/12.2/13.2/0.5' Δ 1220g

■ Valve spring compressor

62104



- For multi-valve petrol and diesel engines, specially designed for difficult access and deep-seated multi-valve cylinder heads.
- Jaw opening 45-145mm, Throat clearance 240mm.



6/15/16/0.9' Δ 2650g

■ Valve spring compressor

62105



Universal overhead cam Applying for most popular cars engines, including AUDI, CHRYSLER, INFINITI, HONDA, HYUNDAI, LEXUS, MAZDA, MITSUBISHI, NISSAN, PORSCHE, SATURN, TOYOTA, VOLVO and VOLKSWAGEN.

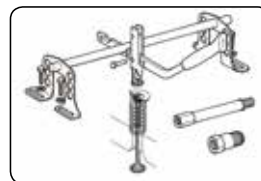

5/17.5/18.5/2' Δ 3.5Kg

■ Valve spring compressor repair kit

62113



- Completes service tool kit for OHV & OHC petrol or diesel engines.
- Use on AUDI, NISSAN, TOYOTA, CHRYSLER, HONDA, MAZDA, MITSUBISHI, PORSCHE, VOLVO, VW.

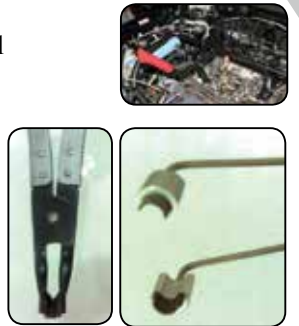

5/20.5/21.5/2.4' Δ 4050g

■ Universal valve-spring compressor tool

908G7



- Suitable for the replacement of valve springs and valve stem oil seals without the need to remove the cylinder head
- Application: Opel, BMW, Seat, VW, Audi, Hyundai, Toyota, Ford 16V, Renault 19 and Clio.

10/18.0/19.0/1.7' Δ 1600g

■ Valve spring compressor

62106



- Compresses overhead valve springs with rocker arm studs.
- This tool can be used with the head either on or off the engine.
- Jaws adjust to fit most overhead valve engines.
- Adjustable handle allows for clearance in tight areas.



24/17.8/18.8/2.1' Δ 740g

■ Valve spring compressor

62107



- Capacity 55-175mm, throat clearance 165mm designed for use on Multi-Valve Petrol and diesel engines with deep Seated valves.
- Collet release adapters: Restricted access adapter, 25mm, 30mm
- Suitable for general use on a wide
- Range of OHC, OHV, and CVH engines. Universal model with unique
- Dual cam-action, parallel lift, and Automatic locking. reversible Jaw/ Adaptor.



10/16.5/17.5/1.2' Δ 1.65Kg

Valve spring compressor

62108



- For large engines & diesel engines
- Unique 'Direct Action' compressor lever gives improved visibility & ease of use in areas of difficult access.
- Collet release adapters: Restricted access adapter, 25mm, 30mm
- Jaw opening 35-142mm, Throat clearance 150mm.



10/19.8/20.8/1.2' 2Kg

Overhead valve spring compressor

62109



- For use on a wide range of OHV OHC and CVH engines but not suitable for use on engines with deep seated valves.
- Allows valve springs and valve stem oil seals to be replaced with the cylinder head.
- Features a reversible JAW/ADAPTOR and an automatic cam-action locking to a pre-determined setting.



20/17.5/18.5/2.1' 875g

Valve spring compressor

62110



- These tools are designed to compress and release valve spring after removing the collets. Pantograph-type levers ensure a consistent coaxial contact with the valve.

Contents:

- 3pc Driving adaptor: 16; 19; 23; 25; 30 mm
- 3pc pressure screw: 70mmL; 110mmL; 120mmL
- 1pc C Clamp



10/21.5/22.5/2.2' 2150g

Valve spring compressor

62112



- Remove and install valve springs with the heads on or off the engine.
- Fits 3/8" and 7/16" rocker studs.
- Handles springs of 1" -2" diameter.
- Press down to compress coil spring, then remove valve keepers and release slowly.



24/29.0/30.0/1.8' 1.2Kg

Valve pressure spring installer/remover for BMW N20, N55

9G0405

NEW



- Special design to remove and install the pressure spring on intermediate lever.
- Applicable: BMW N13, N20, N26, N55.



6/12.9/13.9/1.6' 1924g

Valve pressure spring installer/remover for BMW N51, N52

9G0406

NEW



- Special design for removing and installing pressure spring on intermediate lever.
- Applicable: BMW engine model: N51, N52, N52K



10/9/10.6/1.7' 865g

3pc Valve keeper installing & pick-up tool set

903G1



- This tool holds the valve keepers in its magnetic jaws so you can easily maneuver the keepers into the valve stem grooves for installation.
- Easily reaches into recessed spring pocket to retrieve released valvekeepers.
- Retrieves small parts from any recessed or hidden area.

Contents:

- 3 pcs valve keeper installing tool
- Flexible magnetic pick-up tool



48/15.4/16.4/0.6' 320g

Valve seal removal & installer kit

911G2



- Work on valves still seated or removed.
- Precision-machined seal driving adapters guide the seal for proper setting.

Contents:

- 1pc Valve stem seal pliers
- 1pc Drive handle 6" (150mm)
- 2pc Deep seal driving sockets for seals O.D. 10.8-14.8mm.
- 7pc Seal driving adapters fit seals 5mm, 5.5mm, 6mm, 6.6mm, 7mm, 8mm, 3/8"



10/17.4/18.4/2.1' 1740g

Valve stem seal ring pliers

9G0102



- Long neck designed to reach into confined area of the seal to grip it for removal.
- Gripping serration allows them to grasp both original equipment & aftermarket seals regardless of the configuration.



72/27.4/28.4/2.6' 380g

Extra long valve stem seal ring pliers

9G0103



- For removing valve stem seals in multi-valve engines.
- Jaw longitudinal-toothed avoiding slipping down.
- For deeply levelled valve stem seals.

72/27.6/28.6/2.6' 380g

Valve refacing and seating tools

915G3



- Precision-machined Tungsten carbide blades produce valve seats with: Accurate seat angle / Superior seat surface / True, Flat seal / Seats concentric with valve guide



- Application: Cutter Ø52-Ø65 75° and 60°
- Cutter Ø46-Ø60 45° and 30°
- Cutter Ø44-Ø52 75° and 30°
- Cutter Ø37-Ø46 60° and 45°
- Cutter Ø37-Ø44 75° and 30°
- Cutter Ø28-Ø37 75° and 45°

5pcs Expandable pilot Ø5.5-Ø12.5 "T" handle drive

10/18/19/1.5' 1994g

Vacuum cup valve grinder

902G7



- For grinding flat head, un-slotted valves.
- 1-1/8" and 1-3/8" diameter cups for larger valves.
- 5/8" and 13/16" diameter cups for smaller valves.



108/16.0/17.0/2.9' 100g

Air valve lapper

62114



- 1pc Air valve body
- 1pc 40mm suction rubber cap
- 1pc 35mm suction rubber cap
- 1pc 30mm suction rubber cap
- 1pc 20mm suction rubber cap



- Apply five or six droplets oil or motor oil to the air valve lapper through its air inlet port. (It is recommended to apply oil from time to time to the valve lapper even during the operation, if the lapper is used continuously for an extended period of time.)
- It's advisable to set air pressure at 6 to 8 kg/cm². (85 psi to 100 psi)

12/17.0/18.0/1.2' 1730g

9pc Offset feeler gauge

61803



- Size: 0.009"; 0.015"; 0.016"; 0.017"; 0.018"; 0.019"; 0.020"; 0.021"; 0.026"
- Decimal sizes and metric equivalents on each blades.
- Blades LxW: 4" x 1/2" (100 x 13mm)



100/10.4/11.4/1.1' 104g

Torque angle meter (clip)

9G1801 / 9G1801A



- **9G1801** is used with 1/2" DR.
- **9G1801A** is used with 3/4" DR.
- Commonly used for tightening head bolts and other bolts where a torque angle is required.



24/12.1/13.1/2.1' 500g

Torque angle meter (magnetic)

9G1802 / 9G1802A



- **9G1802** is used with 1/2"DR.
- **9G1802A** is used with 3/4"DR.
- Commonly used for tightening head bolts and other bolts where a torque angle is required.

24/11.3/12.3/2.1' 495g

1/2"DR.100mm Cylinder head bolt tool (M9,M9.5,M10,M12,M14)

348100..

- Size : M9 , M9.5 , M10 , M12,M14
- 1/2" DR. 100mm.
- For cylinder head bolts.



Part no.	Size	l mm	g	Applications
34810009	M9	100 mm	95	VW Golf / Jetta / Audi A4 , TT , A8 / Mercedes Benz M102, 103, 104, 110, 116, 117, 119, 120, 615, 616, 617 / TOYOTA MR2
348100095	M9.5	100 mm	102	FIAT
34810010	M10	100 mm	108	VW / Audi / Vauxhall / Opel / Mercedes vans / Ford
34810012	M12	100 mm	151	TOYOTA Tercel / Mercedes-Benz / New Beetle / Ford / GM / Volkswagen Audi Group
34810014	M14	100 mm	187	Volkswagen / Ford / Chrysler / Rover

M10S Cylinder head bolt tool

34914010V



- 1/2" Drive, 140mm.
- Special for Audi engines, and VW-PASSAT cylinder head screws.



100/13.4/14.4/1.5' 134g

■ **1/2" DR. 150mm Cylinder head bolt tool (E12)**

54615012B

- For BMW cylinder head bolts.
- Applications: BMW M42, M43, M44, M50, M52, M60, M62.



Part no.	socket	mm	g	pc/box
54615012B	E12	150	152	10

■ **Cylinder base surface rectifier**

9G0610

- Straight edge works for precision check the cylinder damage or not.
- Length: 600mm
- Width: 16mm
- Height: 36mm



5/12.2/13.2/0.42' 2450g

■ **4pc Multi-purpose scraper set**

904U1

- This set includes a select of multi-purpose scrapers ideal for a variety of general automotive applications.
- Contains 2pc 3M imperial wetordry paper A Wt.
- Short blades ideal for scraping hard-to-reach carbon deposits.
- Long blade used to scrape engine blocks and heads.
- Rigid carbon scrapers.



10/11.8/12.8/1.6' 1180g

■ **5pc Scraper set**

905M3

- 1 pc 12"(305mm) multi-purpose scraper, blade 1" (25.4mm) wide.
- 1 pc 12"(305mm) multi-purpose scraper, blade 3/4"(19mm) wide.
- 1 pc 7-1/2"(195mm) multi-purpose scraper, blade 1" (25.4mm) wide.
- 1 pc 7-1/2"(195mm) multi-purpose scraper, blade 5/8" angled.
- 1 pc 7-1/2"(195mm) multi-purpose scraper, blade 9/16" angled



12/10.5/11.5/1.55' 875g

■ **4pc Scraper set**

904M4

- 1 pc 12"(305mm) multi-purpose scraper, blade 1" (25.4mm) wide.
- 1 pc 12"(305mm) multi-purpose scraper, blade 1/2"(12.7mm) wide.
- 1 pc 12"(305mm) multi-purpose scraper, blade 1/4" (6.35mm) wide.
- 1 pc 7-1/2"(195mm) multi-purpose scraper, blade 1" (25.4mm) wide.



12/9.5/10.5/1.55' 791g

■ **3pc Scraper knife set**

903M1

- Size 15, 20, 30 mm
- Stainless steel, heat treatment of knife
- High grade wooden grip
- Sharp tip



72/14.2/15.2/2.1' 200g

■ **Engine cylinder hone**

9G0901

- Flexible shaft with an adjustable honing tension capacity: 2"~ 7"
- Stone size: 100 x 10 x 8mm (3pc)
Stone item number : **9G0901S**(#220grit)
- Sleeve makes insertion in cylinder easy and protects stones when not in use.
- Collar prevents stone breakage.
- Fine surface stones: **9G0901SF**(#320 grit)
- Coarse surface stones: **9G0901SC**(#120 grit)



24/17.0/18.0/2.5' 680g

■ **Engine cylinder hone – four Stone**

9G0903

- A rigid cylinder hone has four stones, or blades, each mounted in a carrier.
- Carrier can be expanded by a turning nut at the top of the hone.
- Adjustable honing tension capacity : 75~110 mm.
- Stones item number: **9G0903S** (#320 grit)
- Fine surface stones: **9G0903SF** (#400 grit)
- Coarse surface stones: **9G0903SC** (#120 grit)



4/17/18/1.2' 4130g

Brake / Engine cylinder hone

9G0902



- Flexible shaft with an adjustable honing tension capacity: 3/4" ~2-1/2"
- Stone size: 28.5 x 5 x 3mm (3pc) (Stone item number : **9G0902S**) (#220 grit)
- Sleeve makes insertion in cylinder easy and protects stones when not in use.
- Collar prevents stone breakage.
- Fine surface stones: **9G0902SF**. (#320 grit)
- Coarse surface stones: **9G0902SC**. (#120 grit)



72/8.5/9.5/1.6' 120g

Piston ring service tool set

911G3



- Piston ring compressor w/ratchet key
H:3"(53-125mm), H:3-1/2"(90-175mm), H:4"(90-175mm)
- Piston ring tool capacity: 50-100mm
- Piston ring groove cleaning
Fits: 2"-5"(51 to 127mm)
Blade 1 size: 1/16" to 3/16"
Blade 2 size: 2.0mm to 4.5mm, 1/4"
Blade 3 size: 1.2mm to 5.5mm
- Offset screwdrivers: ⊕ ⊖



6/15.8/16.8/2.9' 2630g

Piston ring compressor

62001



- Install pistons from 2-7/8" to 4-3/8" (73-111mm)
- Ratcheting lock allows the bands to compress in small increments.
- Can be used parallel or perpendicular to the cylinder block.
- Set includes pliers and 6 bands.

Contents :

- 1pc Ratchet pliers
- 1pc Band size 2-7/8" to 3-1/8"
- 1pc Band size 3-1/8" to 3-3/8"
- 1pc Band size 3-3/8" to 3-5/8"
- 1pc Band size 3-5/8" to 3-7/8"
- 1pc Band size 3-7/8" to 4-1/8"
- 1pc Band size 4-1/8" to 4-3/8"



8/10.9/11.9/1' 1487g

Piston ring compressor

62006



- Install pistons from 2-7/8" to 4-3/8" (73 - 111mm) and 4-7/8" to 5-1/8" (124 - 130mm)
- Ratcheting lock allows the bands to compress in small increments.
- Can be used parallel vertically perpendicular horizontally.
- Set includes pliers and 7 bands.

Contents :

- 1pc Ratchet pliers
- 1pc Band size 2-7/8" to 3-1/8"
- 1pc Band size 3-1/8" to 3-3/8"
- 1pc Band size 3-3/8" to 3-5/8"
- 1pc Band size 3-5/8" to 3-7/8"
- 1pc Band size 3-7/8" to 4-1/8"
- 1pc Band size 4-1/8" to 4-3/8"
- 1pc Band size 4-7/8" to 5-1/8"

8/11.4/12.4/1' 1425g

Piston groove cleaner

62003



- Designed for cleaning the piston slots.
- Piston slot size: 2, 2.5, 3, 3.5 mm

40/24.4/25.4/2.1' 570g

Piston ring compressor

620



Part no.	mm	inch	Packing	g
6202080	40-80	2	50/7.8/8.8/1'	156
6203125	53-125	3	50/15.5/16.5/1.3'	310
6203175	90-175	3	50/17.9/18.9/1.3'	365
6204125	90-125	4	50/16.7/17.7/1.3'	335
6204175	90-175	4	50/18.9/19.9/1.3'	380
6206175	90-175	6	20/12.0/13.0/1.6'	600



■ Piston ring pliers

623

• 62302 is applied to truck.



Part no.	Packing	W mm	l inch	g
62301	50/15.0/16.0/2.2'	55-100	3	330
62302	50/18.5/19.5/3'	110-160	3	420
62303	50/8.5/9.5/2.2'	80-120	2.5	170



■ Piston ring installer

62002

- Save by reducing ring breakage.
- Tapered jaws to remove and install most passenger car and light truck rings from 3/64" to 1/4" (1.2mm ~6.3mm)



144/18.0/19.0/2' 135g



■ Chain oil filter wrench (1/2" DR.)

61901

- 1/2" sq. driver or 13/16"(21mm) open end spanner.
- Suitable for filters up to 120mm diameter.



72/18.9/19.9/2.6' 262g



■ Chain locking pliers

61901A

- Cr-Mo jaw and handle
- Welded with a 18" chain



20/16.5/17.5/1.1' 825g

■ Filter chain wrench

61911

- Suitable for filter up to 40mm - 120mm diameter.

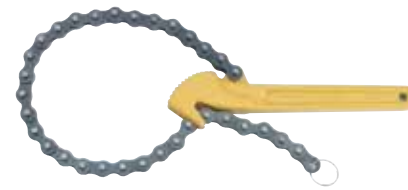

60/22.0/23.0/0.82' 410g

■ 20" Chain wrench

61914

- 20" chain



20/20.0/21.0/0.78' 1kg

■ Oil filter strap wrench

619

It can match with various tools for use 1/2" driver, pliers and screwdriver.



Part no.	Packing	l mm	g
619	60/18.7/19.7/3'	150	310

■ Truck strap oil filter wrench

61902

- The heavy-duty strap can handle any filter up to 6"(150mm) diameter.
- The support pad helps the grip of the filter without crushing it.
- The more leverage applied, the tighter it grips.
- Use with any 1/2" power bar.
- Capacity: 6"(150mm).



48/17.9/18.9/1.4' 372g

Strap oil filter wrench (1/2" DR. & 3/8" DR.)

61903



This robust quality strap wrench is capable of removing filters up to 300mm diameter on cars, vans and trucks.

- The design of this wrench makes it ideal for areas where clearance is restricted.
- The dual drive allows you more flexibility. Besides, the wrench can be used in conjunction with a 13/16"(21mm) open spanner.

40/16.3/17.3/2.8' 408g

Three-legged oil filter wrench

61904



- Removes all oil filters from 2-1/2" to 4-5/16" (65mm to 110mm) in diameter.
- Used with 3/8" square drive tools.



36/21.3/22.3/1.2' 590g

Three-legged two way oil filter spiral wrench

61904A



- Fits 1/2" & 3/8" Square Drive Ratchet Handle
- Operated By 21 mm Hex Adaptor: 1/2" Sq. X 3/8" Sq.
- All Chrome Plated. 3-Leg Two Way Operated Range: 63 ~ 102 mm.



36/15.0/16.0/1.2' 415g

Filter wrench

9B0701 / 9B0702



- Steel jaw grips filter without slipping.
- Use with 3/8" drive.
- The large range enables 9B0701 to fit most standard size filters from 2-1/2" to 3-1/8"(60m/m-80m/m)
- The large range enables 9B0702 to fit most standard size filters from 3-1/8"to 3-7/8"(80m/m-98m/m)



Part no.	Packing	g
9B0701	48/18.1/19.1/1.7'	380
9B0702	48/18.7/19.7/1.7'	380

Filter wrench

9B0703 / 9B0703A / 9B0703B



- The tool with serrated design for better grip on oil filter during removal / installation.
- Use with 1/2" DR. or 21mm wrench.



Part no.	Range mm	Packing	g
9B0703	60-80	30/14.3/15.3/0.55'	475
9B0703A	80-120	15/13.7/14.7/0.48'	913
9B0703B	110-140	15/13.7/14.7/0.58'	913

Self-gripping oil filter wrench

9B0704



- 1/2" DR.
- Suitable for filter 95-165 mm.



10/14.0/15.0/0.81' 1.4Kg

Three-legged oil filter wrench

61913



- 3-leg, 1-way, fit 1/2" square drive
- Capacity 75 ~ 130mm (3" to 5-1/8")

24/24.0/25.0/1.1' 950g

Strap oil filter wrench

61908

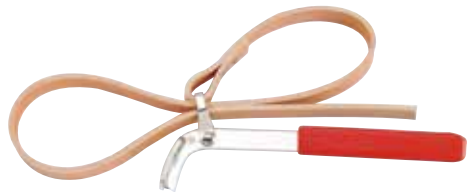

- With non-slip rubber-fabric strap
- Especially suitable for plastic pipes
- Strap length: 420 mm
- Capacity: 130 mm diameter

48/16.2/17.2/2.2' 338g

Strap wrench

61912



- 12" Aluminum handle
- 34" Strap

50/16/17/1.6' 320g

Adjustable oil filter wrench

61909



- Capacity: 80-110 mm diameter

50/17.5/18.5/4.83' 350g

Heavy-duty oil filter wrench

61905



- Wide steel bank designed to meet the high torque requirement of truck, bus, RV and heavy duty equipment filters.
- Used with 1/2" square drive tools.

Part no.	Packing	<i>l</i> mm	g
61905120	36/24.8/25.8/3.0'	4-1/8" to 4-3/4" (105mm - 120mm)	690
61905135	36/25.2/26.2/3.0'	4-1/2" to 5-1/4" (115mm - 135mm)	700
61905145	36/25.6/26.6/3.0'	5" to 5-3/4" (125mm - 145mm)	710

Swivel handle oil filter wrench

61906



Part no.	Packing	<i>l</i> mm	g
61906073	36/12.0/13.0/2.6'	2-3/8" to 2-7/8" (60mm - 73mm)	335
61906085	36/13.4/14.4/2.6'	2-7/8" to 3-3/8" (73mm - 85mm)	372
61906095	36/14.0/15.0/2.6'	3-3/8" to 3-3/4" (85mm - 95mm)	389
61906111	36/14.7/15.7/2.6'	3-3/4" to 4-3/8" (95mm - 111mm)	408

Oil filter wrench

61910

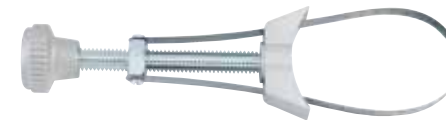

- Spring steel strip
- Aluminium diecast

part no.	Capacity mm	g
61910	65-110	210
61910L	110-155	230

* Spare diecast (band) available, 61910-D/61910L-D

Oil filter pliers

639



Part no.	Size mm	Packing	<i>l</i> inch	g
639250	60-90	60/21.2/22/2.1'	10	354
639300	85-115	60/22.7/23.7/2.5'	12	379
639365	100-140	20/11/12/1.1'	14	550



Oil filter master pliers

639230



Part no.	Size mm	Packing	<i>l</i> mm	g
639230	53-118mm	40/19.5/20.5/1.7'	230	480

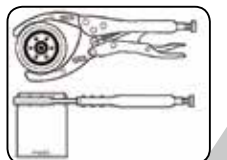

Oil filter wrench -27mm

61927



- This oil filter housing removal for the removal and installation of the specified difficult to access oil filter covers.
- Application:
FORD / PSA 2.0 L Durotorq TDCI / HDI (DW10C) and 2.2 L Durotorq TDCI / HDI (DW12C) diesel engines - S Max, Mondeo, Galaxy, Euro 6 compliant engines from 2010 onwards.

30/19/20/1.5' 680g

Oil filter wrench

631



- Can operate with 1/2" drive.



part no.	mm	Pt.	Application
6316514	64	14	TOYOTA, NISSAN
6316714	67	14	FORD, MAZDA
6317314	73	14	TOYOTA, NISSAN
6317330	73	30	GM, FORD
6317315	73	15	GM, FORD, MITSUBISHI
6317414	74	14	BMW, AUDI, WOLKSWAGEN, OPEL, AUSTIN
6317408	74	8	FIAT
6317415	74	15	GM, CHRYSLER, ROVER
6317515	75	15	GM, CHRYSLER
6317612	76	12	FORD, MAZDA
6317815	78	15	NISSAN, TOYOTA, HONDA ACCORD
6317915	79	15	DAIHATSU, FORD
6318418	84	18	PEUGEOT, CITROEN, RENAULT
6318614	86	14	MAZDA, MITSUBISHI
6318915	89	15	HONDA, MITSUBISHI
6319115	91	15	TOYOTA, NISSAN
6319112	91	12	CITROEN, PEUGEOT, RENAULT
6319115B	91	15	GM, FORD, CHRYSLER, LANCIA, FIAT
6319215	92	15	HONDA, TOYOTA
6319515	95	15	GM, FORD, CHRYSLER, ALFA
63110115	101	15	DAIHATSU, MAZDA, MITSUBISHI, TOYOTA

Cup type oil filter wrench set

61915 / 61916 / 61917

61915



6/18.5/19.5/2' 3200g

61916



5/18.2/19.2/2.4' 3940g

61917



3/21/22/3.2' 7060g



61915	61916	61917	SPCS	Applicate
	•	•	66mm/6P	Flat (Punto, 1.2) Renault (Clio 1.2 Express, Kangoo, Twingo) etc...
•		•	65mm/14P	Fits Champ, Hastings. GM/AC, Wix, Napa, Purolator, Diahatsu, Toyota, Nissan, etc...
•		•	65~67mm/14P	Fits same filters as made in Canada including PH4386, PH4967, PH6017, PH6018. Daihatsu. etc...
•		•	68mm/14P	Fits Hastings, Mazda, Ford Escort, Capri, Subaru, Fran PH6607 (those fram filters made in Korea, motorcraft FL816 etc...
•		•	73mm/14P	Fits Toyota / Lexus, etc...
		•	74mm/15P	Fits MF, Audi, #056-115-561g, GM, Rover, Chrysler. etc...
•	•	•	74~76mm/15P	Fits Fram, AC, Saturn, etc...
•		•	75~77mm/15P	Fits VW, Audi, Casite, GM / AC, Hastings, Wix, NAPA Ford. Isuzu Mercedes, Opel, etc...
	•	•	76mm/12P	Fiat (z.B. Ducato, Scudo, Ulysee), Renault, (Megane, Laguna, Espace III) etc...
•	•	•	76mm/14P	Fits Champion, Champ Lee, Purolator, Mopar, VW, Porsche, Mercedes Benz, BMW, Audi, (I.B.A3TD) Opel. etc...
•		•	76mm/30P	Fits Motorcraft only-FL400A, Ford. etc...
	•	•	76mm/8P	Fiat (z.B.Marea), Lancia (z.B.Delta) etc...
		•	78mm/15P	Fits Nissan # 15208H8991, Ford, Toyota, Accord, etc...
•		•	80mm/15P	Fits Hastings, Fram, Purolator, Nissan, Honda, Motorcraft, Mazda, Isuzu, Subaru, Opel, Toyota, etc...
•		•	80~82mm/15P	Fits Wix filters. Branded for: Mazda, Subaru, Toyota, Honda, Acura, Nissan, NAPA, etc...
	•	•	86mm/16P	Volvo (C40, S60, S70, S80) etc...
	•	•	86mm/18P	VW, Golf (MKIII, Tdi, Passat Tdi), Audi A6 Tdi, Renault (Clio, Rapid 1.9D Laguna, Safrane, Espace 2.1D), Citroen, Peugeot, Renault, etc...
•		•	90mm/15P	Fits Honda Accord, Mitsubishi, Mopar, Isuzu etc...
	•	•	92mm/10P	Fiat, Cinquedento, Coupe, Croma, Fiat, Panda, Regata, Ritmo Fiat, Seicento, Tempra, Tipo, Lancia (Beta, Dedra, Kappa, Monte, Carlo, Prisma, Thema, Trevi) etc...
•	•	•	93mm/15P	Fits Casite, Champ, Champion, GM, Fram, Hastings, Opel, Mazda, Volvo, Mitsubishi, Purolator, Wix, Nissan, VW, Porsche, Renault Ford, Honda, Audi, etc...
•		•	93mm/36P	Fits Motorcraft only-FL1A, FLA1B, FL300, FL820, Ford, etc...
	•	•	93mm/45P	VW-Audi. (Tdi 2.4, 2.6, 2.8L) etc...
		•	95mm/15P	Toyota # 15600-41010, Alfa, GM, Ford, ALFA, Chrysler, etc...
	•	•	96mm/18P	Audi (A4, A6. Tdi), VW(Passat 97 Tdi) Renault(Laguna 2.2d, Safrane 2.2D.) Espace 2.2D, R19, Rapid, Megane 1.9 / 2.1D.TDi) etc...
•		•	100mm/15P	Fits fram, Motorcraft, wix, Isuzu and Mitsubishi, etc...
	•	•	106mm/15P	Fiat (Ducato 2.5D. Td) etc...
	•	•	108mm/15P	Volvo (C70, S70, V70. Tdi. TD) (Turbo. Diesel. 850 Tdi. Diesel) etc...
	•	•	108mm/18P	Renault (Espace, Laguna, Master, Safrane, Traffic 2.4, 2.5, 2.8D,TD) etc...
	•	•	Two way oil filter wrench	
•	•	•	Adaptor	

Oil filter wrench for Toyota / Lexus

631B02



- Special design for plastic oil filter cap of Toyota and Lexus
- Size: 3/8"DR. , 64.5 mm, 14PT
- Applicable: Allion, Auris, Corolla axio, Corolla fielder, Corolla rumion, Isis, Ist, Noah, Premio, Prius, Wish, RAV4, Yaris, ES350, GS300, GS350, GS450h, IS250, IS350, LS460, LS600h, RX350



100/16.3/17.3/1.9' 163g

Oil Filter Wrench for Mercedes Dodge Jeep

61935



NEW

- Size: 84mm x 14 point x 1/2"Dr.
- Designed for removing the oil filter housing on various engines when changing the oil and oil filter.
- Application: 2007 Dodge sprinter, 2007 Mercedes Benz E320, 2007 Jeep Cherokee with 3.0L V6 diesel engine



20/15/16/0.65' 750g

4pc Oil filter cap wrench set

61920A



- 3/8" Square drive.
- Size: 27mm, 32mm, 36mm, 38mm
- Applicable: MERCEDES, VAUXHALL/ OPEL, BMW, FORD.



20/15/16/0.65' 750g

5pc Oil filter cap wrench set

61920B



- 3/8" Square drive.
- Size: 24mm, 27mm, 32mm, 36mm, 38mm
- Applicable: CADILLAC, MERCEDES, VAUXHALL/ OPEL, BMW, FORD.



20/16/17/0.65' 800g

3pc Cap oil filter wrench

61920



- 3/8" Square drive.
- Size: 27mm, 32mm, 36mm
- Applicable: MERCEDES, VAUXHALL/ OPEL, BMW, FORD.

20/12/13/0.65' 600g

8 & 10mm Oil service wrench

9U0706



Chrome-vanadium, chrome-plated with 8 and 10 mm outside square drive for various French passenger cars, oil drain plug on oil pan, gearbox, differential.



50/17.3/18.3/1.84' 344g

8 & 8mm Oil service wrench

9U0710

Chrome-vanadium, chrome-plated with 8 and 8 mm outside square drive for various French passenger cars, oil drain plug on oil pan, gearbox and differential.



50/12.8/14.6/1.6' 255g

Oil service wrench

9U0711

NEW

•For the oil filter and oil drain plug gear box, differential oil pan on various French passenger cars.

•Length: 245 mm

•Size: M10 female X 10mm square male



Composite drain key

890220

• Size: 8.7mm, 9.5 mm, 10.5 mm, 11.5 mm, 13 mm, 6.8 mm, 15.2 mm, 16.5 mm, 19.7 mm

• Length: 220mm



20/8.8/9.8/0.56' 440g

5pc Fill / Drain plug key set

5051

Contents:

- 5051-1 5-Fill / drain plug key
- 5051-1 17mmHex - 14mmHex
- 5051-2 10mmHex - 12mmHex
- 5051-3 9mmHex - 5/16"Hex
- 5051-4 8mmSq. - 13mmSq.
- 5051-5 3/8"Sq. - 11mmSq.



25/11.5/12.5/0.64' 460g

6pc Fill / Drain plug key set

5061

Contents:

- 6-Fill / Drain plug key
- 5061-1 5/16"Hex - 3/8"Hex
- 5061-2 8mmSq. - 3/8"Sq.
- 5061-3 11mmSq. - 12mmHex
- 5061-4 13mmSq. - 14mmHex
- 5061-5 17mmHex - 1/2"Hex
- 5061-6 8mmHex - 10mmHex



25/17.9/18.9/0.64' 720g

12pc Auto kit set

5122

Contents:

- 6- Fill / Drain plug key
- 5061-1 5/16"Hex - 3/8"Hex
- 5061-2 8mmSq. - 3/8"mmSq.
- 5061-3 11mmSq. - 12mmHex
- 5061-4 13mmSq. - 14mmHex
- 5061-5 17mmHex - 1/2"Hex
- 5061-6 8mmHex - 10mmHex
- 8074 16M...20.6M 1/2"DR. Magnetic spark plug socket 16mm; 20.6mm
- 810421 Plug key holder 1/2"(F)x21mm(F)
- 617 Telescope mirror stick / magnetic pick-up
- 618 20pc feeler gauges 0.05mm to 1mm
- 619 Oil filter strap wrench



6/11.8/12.8/0.9' 1970g

15pc 3/8"DR. Drain nut

915G2

The drain nut set has different external shape to fit different requirements.

We offer also the drain nut set without driver.

- 9.5mm
- 10mm
- 8, 9.5, 11, 12, 13 mm
- 8, 9, 9.5, 10, 12, 14, 17 mm



10/20.0/21.0/1.3' 750g



■ **1/2" DR. Drain nut socket bit (M16H)**

348...T



Part no.	size	l mm	g	pc/box
34805516T	M16H	55	142	10
34810016T	M16H	100	270	10



- For removal and replacement of the gear box drain plug Audi A3, A4, A6; VW Golf IV, LT.

■ **Assembly tool for plastic oil drain plug (VAG group)**

61930

NEW



- Required for proper removing and installing of the special plastic oil drain plug (M14 x 1.5 x 22) at plastic oil pan.
- For VW, Audi, Skoda, Seat 1.2, 1.4, 1.8, 2.0 TFSI; 1.6, 2.0 TDI



72/6.5/7.5/1.4' 76g

■ **Magnetic oil drain plier**

61933

- Drain old and hot engine oil, transmission fluid, and gear oil without danger.
- High-power magnet grips oil plug well.
- Pleasant oil changing work.
- Patented handle provides comfortable gripping.
- Universal application.



■ **64pc Oil drain repair kit**

964G1



- Renew the diameter and replace a new oil drain plug.
- Four popular sizes fit nearly all applications.
- Specification: M13x1.5P, M15x1.5P, M17x1.5P, M20x1.5P
- Tap: 1 piece / size, material: SKS3
- Oil drain plug: 5 pieces / size, material: 1015
- Washer: 10 pieces / size, material: Copper



12/18.0/19.0/2.2' 1460g

■ **Oil filter drain tool (Toyota & Lexus)**

61923



- Provide a professional and clean work when changing oil filter.
- Available for many Toyota & Lexus (2006~) 4cyl and 8cyl vehicles.



40/11.2/12.2/2.9' 280g

■ **Oil filter drain tool (VW)**

61925



- Provide a professional and clean work when changing oil filter.
- Available for many VW 2.0 vehicles.



Golf V 2.0T 2.5
Golf V (all) 2.5T
Jetta V (all) 2.0T
Passat B6 (all) 2.0T

40/7.4/8.4/3.6' 170g

Flexible / Moldable funnel

61926



- Flexible funnel provides easy job for draining or refilling wide kinds of fluid and oil.
- Suitable application: engine oil, coolant, brake oil, auto transmission oil...etc.
- Easy to take anywhere, use to limited space, and easy storage.
- Size: 372mm x 170mm

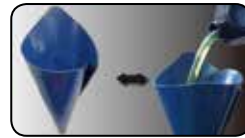

50/11.5/12.5/1.0' 230g

Oil funnel with piercer

61928



- Oil spill eliminator, no more unpleasant spills.
- Efficiently improves oil-changing process.
- Transparent lower chamber design clearly show oil flow process.
- Hand free design of piercer securely holds bottles.
- Pierces bottle seals and prevents seals from falling into engine.
- Piercing function saves time and prevents engine oil or transmission fluid additives from spilling.
- Special filter mesh efficiently blocks impurities without extending oil-changing time.
- Connect thread-good fitting with thread funnel & current M37 x P3.0 funnels on market.
- Application: Lexus, Toyota, Scion, VW, Audi, BMW, Mercedes, Benz, Porsche, Chevrolet, Geo, Volvo

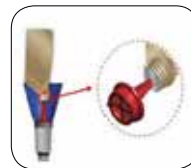

10/3.0/4.0/1.57' 340g

Oil funnel with piercer

61929



- Oil spill eliminator, no more unpleasant spills.
- Efficiently improves oil-changing process.
- Transparent lower chamber design clearly show oil flow process.
- Hand free design of piercer securely holds bottles.
- Pierces bottle seals and prevents seals from falling into engine.
- Piercing function saves time and prevents engine oil or transmission fluid additives from spilling.
- Special filter mesh efficiently blocks impurities without extending oil-changing time.
- Connect thread-good fitting with thread funnel & current M32 x P3.5 funnels on market.
- Application: Acura, Chevrolet, Chrysler, Dodge, Eagle, Ford, Geo, Hyundai, Honds, Isuzu, Infiniti, Jeep, Kia

10/2.6/3.6/1.57' 300g

2pc Universal oil funnel

902G23

NEW



- The width of the clamp is automatically adjustable 28mm-74mm (1.1in-2.9in).
- The funnel has a thread that fits perfectly in the clamp.
- The funnel has a special transparent design in the lower chamber to see the passage of the oil.
- No need to hold the funnel with your hand when refilling the oil.



12/7.3/8.3/4.1' 608g

Transmission oil gauge

9G1803 / 9G1804

9G1803

- Dipstick for determining oil level
- Transmission 722.6

100/16.5/17.5/1.9' 165g

9G1804

- Dipstick for determining oil level
- Transmission 716.5, 722.7

100/11.6/13.0/1.9' 116g

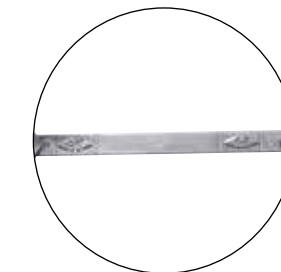

Oil gauge

9G1805 / 9G1806

9G1805

- Dipstick for determining oil level and inspecting length of dipstick guide tube

100/5.4/6.4/1.4' 54g

9G1806

- Measuring rod for measuring oil level and for checking length of oil pipe.

100/5.2/6.2/1.4' 52g

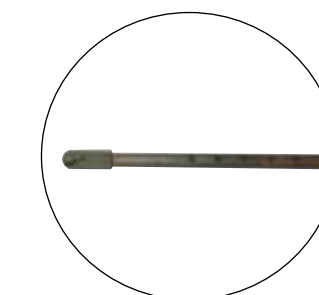

Oil cooler line pliers

9G0717



- Release the hydraulic cooling lines that connect to the transmission.
- Front clips fixed by screw can be adjusted at different angle for the convenience of use.
- Applicable:BMW E46, E53, E60, E61, E63, E64, E65, E66, E70, E81, E83, E85, E86, E87, E90, E91, E92, E93, R50, R52, R53, Rr1



48/18.0/19.0/2.1' 375g

Fuel injector remover/installer tool for BMW N55

9G0127

NEW



- Special design to install and remove the injector in N55 engine.
- Applicable:BMW N55 engine.

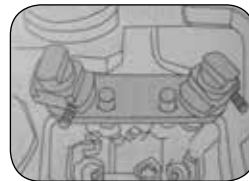

20/12/12.4/0.67' 525g

Fuel injector remover/installer tool for BMW N20/N55

9G0128

NEW

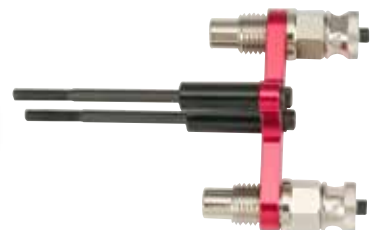

- Special design to install and remove the injector in N20, and new N55 engine.
- Applicable:BMW N22&N55 engine.



10/6.5/7.5/0.64' 536g

Fuel injector remover/installer tool for BMW N63

9G0130

NEW



- Special design to install and remove the injector in N63 engine.
- Applicable: BMW N63 engine.



72/17.5/18.5/0.94' 243g

Fuel feed pipe pliers

9G0715

- For undoing quick-release connections on fuel feed pipe lines.
- Application:Opel/Vauxhall, Fiat, GM, VW etc.



72/17.5/18.5/0.94' 243g

Fuel line pliers

9G0716

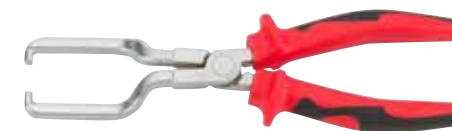

- Quick and easy fuel connector removal and replacement
- For use on fuel filter connectors during replacement
- Prevents fuel leakage from damaged fuel connectors
- Applications:Audi, VW, GM, Mercedes including M-class, Toyota, Fiat, Opel.



48/16.0/17.0/2.4' 335g

3pc Fuel line disconnect set

903G2



- Designed for uncoupling quick-release fittings on fuel line to most of the cars.

Contains:

1. 1/4" 5/16" (Ø8mm), for: Ford-Mercury, Dodge-Chrysler, Renault
2. 3/8" (Ø10mm), for: Ford-Mercury, Dodge-Chrysler, Renault
3. For: G.M., Chevrolet, Buick-Pontiac, Renault/Fiat Ford / Opel



60/7.3/8.3/4.8'

305g

3pc Benz fuel tank cap wrench

903U2

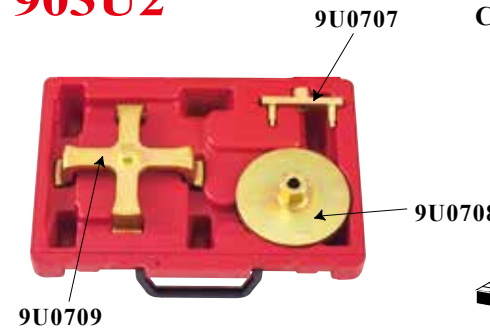

Contents:

- 9U0707:** Benz W210 Fuel tank cup wrench
- 9U0708:** BENZ-W202 Fuel tank cap wrench
- 9U0709:** BENZ Fuel tank lid dissembler wrench



5/10.5/11.5/1.37'

2.1Kg

Adjustable fuel tank lid remover

9G0713



- Jaw adjustable range:122~199mm,suitable for different fuel tank lid.
- Special jaws designed to remove & install the tank closely.
- Use with 3/8"DR. wrench



24/16.0/17.0/1.2'

497g

Ford fuel pump wrench

9G0706



- For removal and installation of the fuel pumps with a plastic retaining nut.
- Suits all Ford falcon models XE, XF to current.
- Diameter: 6-1/8" (155mm)

36/15.3/16.3/3.1'

425g

Fuel tank lid remover/installer for BENZ(W211/W203)/ BMW(E36/E46)

9G0725

NEW



- For removing the tank lid while fixing or replacing the fuel tank.
- The tool will help you remove the tank lid easily.
- Application:BMW (E36 / E46), BENZ (W211 / W203) .

18/19.5/20.5/0.8'

1146g

Fuel tank lid wrench for BENZ(W164/W166/W251)

9G0720

NEW



- Used to remove the plastic fuel tank lid.
- Size: Dr.1/2"x 22 points
- Application:BENZ W164,W166,W251 .

1115g

Fuel tank locking ring tool for VW/AUDI

9G0721

NEW



- Designed to remove and install the fuel tank locking ring.
- 120mm internal diameter with 3 slotted teeth to grip ring.

• Application: Audi - A3, A4, A6, A7, A8, Q3, Q5, Q7, R8, TT.

VW - Polo, Beetle, Golf, Golf Plus, Golf Cab, Jetta, Eos, Scirocco, Passat, Passat CC, CC, Sharan, Touran, Tiguan, Touareg, Phaeton, Caddy, Transporter including LCV models.



24/18.1/18.6/0.96' 714g

Fuel tank locking ring tool for BMW/MINI/PORSCHE

9G0722

NEW



- This tool is designed to remove and install the fuel tank locking ring.

• Application: BMW-E31, E34, E36, E38, E39, E46, E53, E60, E63, E64, E65, E83, E85, E90
Mini-R50 / R52 / R53 / R55 / R56 / R57
Porsche-Boxster, Cayman (986), 911 Carrera, Turbo / GT2 / GT3 (997)



24/12/13/2' 480g

Fuel Filter Wrench 108mm

9G0727

NEW



- For removing and refitting fuel filter cap when replacing
- Application: Citroen, Peugeot and Renault with HDI diesel engines.



30/12.8/13.8/2' 425g

Fuel filter cover mounting tool for VW, Audi, Skoda and Seat

9G0726

NEW



- The fuel filter cover mounting tool is designed to press the fuel filter cover evenly and in a torsion-free manner into the seal seat in the fuel filter housing.

• Application: VW, Audi, Skoda and Seat diesel vehicles with UFI fuel filter housing. (2.0L TDI CR)



Diesel fuel filter removal tool

9G0723

NEW

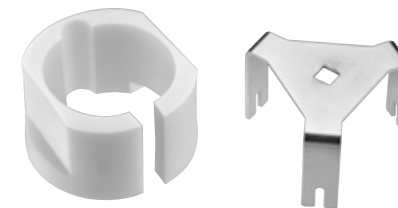

- Filter housing fits into the plastic holder using a vice, so the key can be used to unscrew the housing cap without causing damage.

• Designed to remove the fuel filter on diesel 1.3, 1.9, 2.0, 2.2, 2.3, 2.8, 3.0 engine..

• Application: Fiat, Lancia, Alfa Romeo, Opel, Vauxhall, Holden, Chevrolet, Citroen, Peugeot, Suzuki and Saab



24/15.2/15.7/2' 560g

Fuel pump wrench

9G0711

- Wrench for removal and installation of the fuel pump

• Applications:
VW Passat (1998-2005)
AUDI A4(2000-2004), A6(1999-2004)



30/12.8/13.8/2' 425g

Fuel transfer tool

63302



- Transferring fuel from car to car.
- Pumping fuel into the heater.
- Extracting fluid from tank.
- Can be used to prime FORD, MONDEO diesel engines.

50/15.3/16.3/2.6' 306g

Diesel injection priming tool

63303



- A Suitable tool for Vauxhall 2.2Di and 2.0Di diesel engines with engine codes X20DTL / X20DTH / X22DTH.
- For the introduction of fuel into the fuel pump after replacement of the fuel filter.

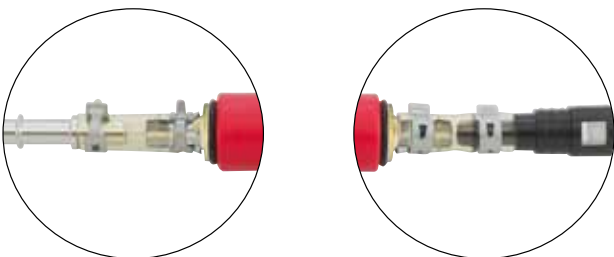

Fuel & transmission line disconnect set

912G3



- A complete set of disconnect tools.
- With aluminum disconnect tool (1/4", 5/16", 3/8", 1/2"), two ends disconnect tool (5/16"~3/8"), long disconnect tool (1/2"), round disconnect tool (1/2"), two point disconnect tool & rubber cap x 4.

36/19.0/20.0/2.5' 520g

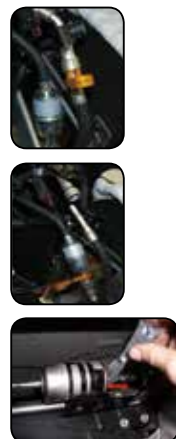

A/C Fuel line spring lock coupling tool set

902G21



- Tools service most types of quick-disconnecting fittings used on Ford, GM & Chrysler vehicles.
- 1pc - Ford/Chrysler/GM fuel line disconnect tool 5/16" & 3/8"
- 1pc - A/C & fuel line spring lock coupling tool 3/8", 1/2", 5/8" & 3/4"



BMW line disconnect tool

9G0718



- Removes covers for both power steering and transmission oil cooler line.
- Made of red anodized aluminum.
- Applicable: 1999-2005 BMW 3-Series and X5.



144/5.0/6.0/1.0' 35g

BMW line disconnect tool

9G0719

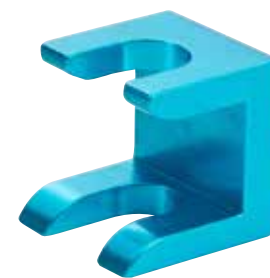

- Removes covers for both power steering and transmission oil cooler line.
- Made of blue anodized aluminum.
- Applicable: 2006-2011 BMW 3-Series and 2006-2009 X3(E90 & E83).



288/7.5/8.5/1.8' 26g

A/C spring lock coupling tools

904G10



- For 3/8", 1/2", 5/8", 3/4" couplers.
- Designed for separating air conditioning refrigerant pressure lines on these vehicles.
- Used for Ford, Chrysler and Jeep vehicles.



144/13/14/3.6' 80g

A/C, fuel line disconnect tool set

907G10



- Easily disconnects air conditioning lines, quick connect fuel lines or can be used as push lock connectors on radiator and transmission lines.
- Size include: 1/4", 5/16", 3/8", 1/2", 5/8", 3/4", 7/8"



72/9.5/10.5/2.7 120g

Oil & fuel pipe stopper

904G12



- Use to plug steel lines once disconnected.
- Prevents fluid leaks and contamination during service.
- Use with any automotive fluid.
- Spring loaded design installs in seconds.
- Specifications: Banjo, 3/8", 5/16", 1/2"



48/7.5/8.5/2.5' 157g

Universal steel line stopper

9G4301



- Suitable for clamping and sealing steel line on braking system, cooling system, fuel line, A/C line etc.
- Provides an effective seal to steel lines when disconnected.
- Prevents fluid loss and contamination in the work area.
- 5/16", 3/8", 1/2" and banjo (10.4mm & 18mm)

72/14.8/15.8/2.65' 205g

Universal oxygen sensor socket

9G1401



- Works on most vehicle oxygen sensors.
- A slot provided in the side of the socket allows wire clearance.
- Outside rib provides added strength.
- 1/2" SQ. DR., 1" Male Hex DR
- 7/8" 6PT. Hex socket

36/16.7/17.7/1.5' 460g

7pc Sensor & sending unit socket set

907G2



- Designed for removing oxygen sensor.

Content:

- 01-22mm (7/8") Heated oxygen sensor socket (1/2" DR. x 7/8" x 50mmL)
- 02-22mm (7/8") Low profile offset socket (3/8" DR. x 7/8" x 30mmL)
- 03-22mm (7/8") Oxygen sensor socket (3/8" DR. x 7/8" x 6pt. x 80mmL)
- 04-22mm (7/8") Universal vacuum Pvs, Tvs valve & oxygen sensor socket (3/8" DR. x 7/8" x 6pt. x 90mmL)
- 05-1" & 1-1/16" Oil pressure sending socket (3/8" DR. x 1" x 1-1/16" x 74mmL)
- 06-1-3/16" Oil pressure sending socket (1/2" DR. x 29mm x 6pt. x 90mmL)
- 907G2P3** -1-1/16" (27mm) GM Thermal sensor switch socket (1/2" DR. x 27mm x 12pt. x 78mmL)

10/21.4/22.4/1.2' 2140g

Oxygen sensor socket

9G1403



- Applicable: FORD, TOYOTA, NISSAN, BENZ, BMW and most of European cars, also GM vehicles.
- Flare nut for vacuum switch & oxygen sensor service on the computer-controlled engines.
- Features: 3/8" of the double square DR. 7/8"(22mm) 12 point & 22mm 6 point.

120/21.8/22.8/2.4' 181g



1/2" DR. Extra long oxygen sensor socket

44315022



- For removing and install lambda sensors with a deep-seated hexagon.
- Size: 1/2" DR. 22mm x 6PT x 150L.
- Application: MERCEDES-BENZ C/E, 602, 605, 606 VW/AUDI/SKODA/SEAT, BMW, FORD, OPEL, ROVER, VOLVOL.

48/17.4/18.4/1.51' 362g

Oxygen sensor rethread tool

63007



- Cleans threads in oxygen sensor holes.
- Use with 3/4" hex socket or 3/8" square drive.
- M18x1.5 also works on M18x1.5 spark plug threads.

144/14.0/15.0/1.6' 90g

Air bag removal tool

907G5

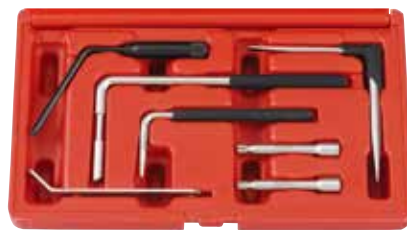

- Airbag removal tool is used to remove driver's airbag from steering wheel on 1999-04 new bodystyle VW Passat, Jetta, Golf and Beetle.
- Mercedes-Benz, BMW (neue Modelle)

20/11.6/12.6/2' 580g



VW Air bag removal tool

9G0301



Air bag removal tool is used to remove driver's air bag from steering wheel on 1999-04 new bodystyle VW PASSAT, JETTA, GOLF AND BEETLE.



120/3.1/3.2/1.4' 26g

Crank seal remover & installer kit

920G1



- Allows the crank seal to be replaced without dismantling the crank case.
- Universal use covering a wide range of cars with oil seals between 27mm and 58mm in diameter.
- Use the existing bolt in the vehicle for installation.
- Screw-type adapter to fit the centering.
- The blue seal adapters are made of aluminum to prevent the damage of crank.

Note: Some cam seals have screws to prevent remove. Do not attempt to use this tool by power.

10/18.0/19.0/1.8' 1750g



Crankshaft & camshaft seal remover and installer set

927G1



- Ideal for both crankshaft and camshaft seal.
- Quick and easy work for both removal and installation work.
- Provided with 2 seal removers with different length and angle fits wide applications.
- Master kit includes wide size seal installers.
- Angled blade seal remover is ideal for removing seals in limited space.



3pc Seal puller

903G13



- Quickly and easily remove O-Ring or grease and oil seal.
- Special angle on the tool head provides a better work than traditional seal pullers.
- 3 different lengths and tips fit nearly all seal applications.
- Simple insert the tool tips, press and pull.
- Length: 165, 117, 150mm

40/10/11/1.4' 200g



Seal puller

9G0113



- Use to remove oil and grease seals.
- Two different size tips enables this tool to accommodate most applications.



60/22.2/23.2/3' 375g

5pc Mini pick and hook set

905G6



- Miniature pick set.
- Removes O-rings in line connections and inside compressors.
- Aluminum handles with 4 stainless tools:
 - 1.awl end
 - 2.hook end
 - 3.45° bent tip
 - 4.90° bent tip



192/8.4/9.6/1.2' 44g

4pc Hook & pick set

904U4



Contents:

- 904U4P1 1-Full hook
- 904U4P2 1-90° hook
- 904U4P3 1-Angel hook
- 904U4P4 1-Straight pick

60/18.5/19.5/2.5' 309g

7pc Universal hook & pick set

907U1

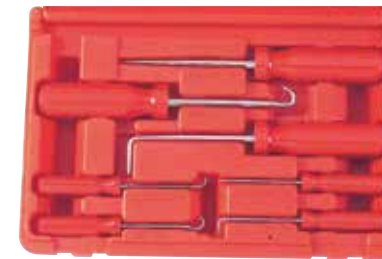

- Tools for household use, repair garages, and factories.
- For punching, marking and line-up work.
- Ideal for separating wires.
- Removing small fuses, stuck parts.
- Pull "O" rings, seals, cotter pins and brushes quickly and easily.
- Remove spring from oil burner relay boxes.
- Retrieve lost nuts, bolts, washers and tools from tight areas.
- Brake spring puller, heavy-duty spring hook.
- Heavy-duty hook and cotter pin extractor.

10/9.7/10.7/1.3' 970g

4pc Cup rocket set

904T2

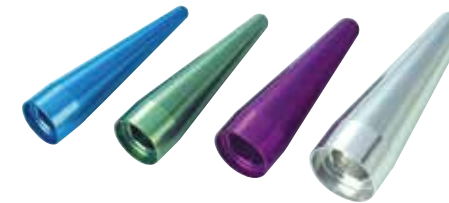

- This tool enables cups to be installed smoothly without scratching damage to O ring cylinders
- Available Size:
 - 9/16" (Ø14.4mm – Ø16.0mm)
 - 5/8" (Ø15.9mm – Ø17.5mm)
 - 11/16" (Ø17.5mm – Ø19.1mm)
 - 13/16" (Ø20.7mm – Ø22.4mm)



144/16/17.5/1.5' 11g

7pc Cup rocket set

907T1



- This tool enables cups to be installed smoothly without scratching damage to O ring cylinders
- Available Size:
 - 9/16" (Ø14.4mm – Ø16.0mm)
 - 5/8" (Ø15.9mm – Ø17.5mm)
 - 11/16" (Ø17.5mm – Ø19.1mm)
 - 13/16" (Ø20.7mm – Ø22.4mm)
 - 15/16" (Ø24.0mm – Ø26.0mm)
 - 1" (Ø25.5mm – Ø27.5mm)
 - 1 3/16" (Ø30.3mm – Ø32.3mm)

60/20.2/22/2.3' 336g

■ Transverse engine supports - for General engines

9G0612

- Straddling the inner fender walls and acting as a bridge to support engines.
- Adjustable in height and width to bridge various vehicle fender walls and securely hold engine in place.
- Including slide bolt that can be positioned anywhere on the bar for the best weight distribution.
- Capacity: 500 kg

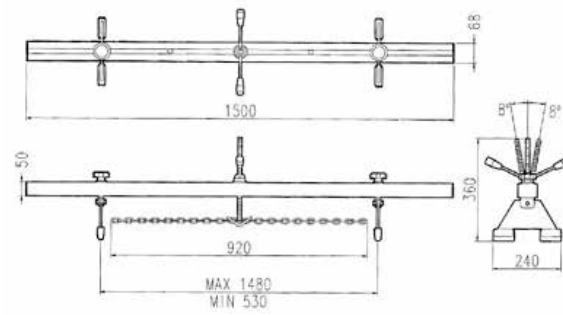

1/11.5/13.1/1' 11.5kg

■ Transverse engine supports - for general engines and bigger engines, multi-way

9G0613

- Special new design for 5 fixing point to be a bridge to support the engine.
- Adjustable in height, position, width, and angle to bridge various vehicle fender walls and securely hold engine in place.
- Total length of middle part 1510mm, width 40x40mm



1/15.5/17.0/1.1' 15.5kg

■ Engine crane 1 ton

9G0615

- Four position telescopic boom with forged steel grab hook.
- Quick foldable legs save shop space and prepare crane for transportation or storage within seconds.
- Four full swivel casters provide easy manoeuvring and positioning.
- New 5 ton capacity long stroke ram is designed with swivel handle to provide fast engine removal and replacement from any direction.
- Capacity: 1000 kg

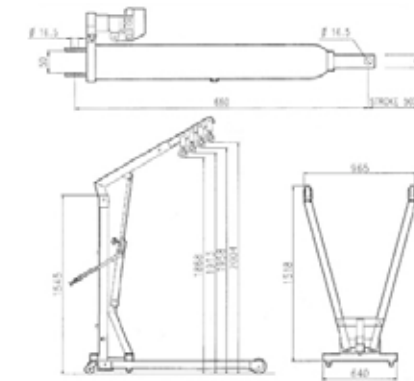

1/91.0/106.0/14.0' 91kg

■ Engine lift chain

9G1511

- For removal of car and light commercial vehicle engines.
- Unique self balancing and securing link lock feature, ensures safe and non-slip lifting.
- Never exceed the maximum load of 450 kg.
- Do not attach ends more than 510mm (20") apart.



12/14.0/15.0/0.7' 1080g

Brass R12 , R22 A/C & refrigeration manifold gauge (with 60" hose 1/4" SAE)

9G4101

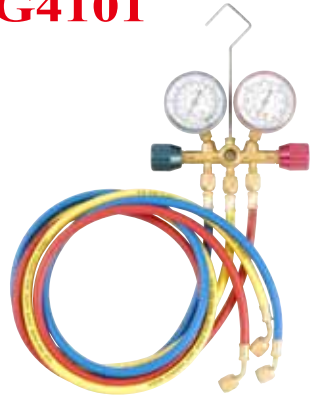

- R-12 , R22 sight glass manifold with three 60" 1/4" SAE color-coded hoses.
- With sight glasses.
- High pressure:0~500 psi
0~3400 Kpa
- Low pressure:0~250 psi
0~1700 Kpa
- Vacuum:0~76 in/Hg

10/13.4/14.4/2.4' 1344g

Aluminum R12 , R22 , R134a Auto A/C manifold gauge set (with 60" hose 1/4" SAE and 2 couplers)

9G4102



- R-12 , R22 , R134a sight glass manifold with three 60" 1/4" SAE color-coded hoses and 2 couplers.
- With sight glasses.
- High pressure:0~500 psi
0~3400 Kpa
- Low pressure:0~250 psi
0~1700 Kpa
- Vacuum:0~76 in/Hg

10/18.9/19.9/2.4' 1885g

Aluminum R404A , R407C , R507A A/C & refrigeration manifold gauge (with 60" hose 1/4" SAE)

9G4106



- R404A , R407C , R507A sight glass manifold with three 60" 1/4" SAE color-coded hoses.
- With sight glasses.
- High pressure:0~500psi
0~35kg/cm²
- Low pressure:0~350psi
-1~25kg/ cm²
- Vacuum:0~76 in/Hg

16/26.0/27.0/3.9' 1625g

Aluminum 4-way R134a Auto A/C manifold 80mm gauge set (with 60" hose 1/4" SAE and 2 couplers)

9G4108



- R134a 4-way sight glass manifold with three 60" 1/4" SAE color-coded hoses and 2 couplers.
- With sight glasses.
- High pressure:0~500psi
0~35kg/cm²
- Low pressure:0~350psi
-1~25kg/ cm²
- Vacuum:0~76 in/Hg

8/24.0/26.0/2.3' 3000g

Aluminum 4-way R410 A/C & refrigeration manifold 80mm gauge set (with 60" hose 5/16" SAE and 2 connector)

9G4107



- R410 4-way sight glass manifold with four 60" 5/16" SAE color-coded hoses and 2 connector (1/4" SAE)
- With sight glasses.
- High pressure:0~800psi
0~55kg/cm²
- Low pressure:0~500psi
-1~35kg/ cm²
- Vacuum:0~76 in/Hg

8/23.0/27.0/4.85' 2875g

Valve core remover & installer tool kit

911G8



- Service valve cores without losing the system charge.
- Unique design offers a locking device that holds the shaft in place while removing or installing the valve cores.
- Contents:

1. Valve assembly
2. Standard valve core remover / installer
3. GM large bore valve core remover / installer
4. JRA R134a valve core remover / installer
5. Volvo and 8mm
6. 2 side valve core remover / installer
7. 1/4" FL swivel connect
8. 16mm high side quick connector
9. 13mm low side quick connector
10. 1/4" x 3/16" adapter
11. 1/4" x 1/2" adapter
12. M12x1.75 FL swivel connector
13. H14 Wrench



20/16.4/17.4/0.96' 820g



■ Universal A/C system testing adapter

958G1



- All brass fittings.
- All HNBR gaskets.
- Special universal design for all systems.
- For leak testing & flush fittings.

6/15/16/2.3' 760g

■ Scale injector

9G4111



- Special design with scale to inject the dye and pack oil for R134a and R12 system.
- Capacity: 1/4 oz.(7.5ml) to 2 oz.(60ml).

20/15.2/16.2/1.9' 760g

■ 5pcs Auto A/C swivel adaptor kit

9G4121

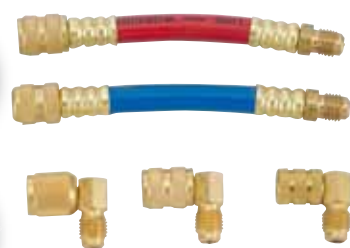

- All the adaptors have been combined into a kit ideal for accessing R12 vehicle A/C system, as well as other types of system
- Eight different adaptors are included with 1/4" fittings.
- Two flexible adaptors: 1/4"x3/16", 1/4"x1/8"
- Three 90° brass adaptors: 1/4"x1/4", 1/4"x3/16", 1/4"x1/8"

100/25.0/26.0/1.6' 250g

■ A/C Adapters (GM)

9G4122



- Applicable: The joint for GM model and most American cars.

100/4.0/4.5/0.2' 40g

■ R-134a Quick coupler set

9G4123



- Including the high-side and low-side coupler.
- Straight design suitable for confined space.

100/19.0/20.0/1.3' 190g

■ R-134a Adjustable quick coupler set

9G4125



- Inclosed the high side and low side coupler.
- The valve core puller is adjustable to fit the different valve core.

48/19.2/20.2/1.2' 400g

A/C compressor clutch remover kit

912G11



- Replace clutches found on FS6, C171, 6P & 148 computer.
- Also GM R4 & R6, HR-6, DA-6 & V5 A/C compressors.
- Works on compressors of Sanden SD505, 507, 508, 510, 575, 708 and 709.
- 2 & 3 hole puller plate fits most clutches and the mechanical force generated pulls it out.

12/15.0/16.0/1.28' Δ 1250g

Flush kit

902G20



- Volume:1L
- Flush solvent performs all mechanical actions required to clean out contaminated systems.
- The cylinder is equipped with a top inlet fitting and a side outlet for connecting to compressed air lines.
- With a gun to control on /off.

10/7/8/1.6' Δ 695g

12 Volt UV detection light

902G10



- For air condition leakage check.
- High intensity 12 volt UV lamp.
- Long cord for easy access .
- Detects all dyes.
- UV Safety Glasses Included.

20/10.4/11.0/2' Δ 520g

2. Electrical / Cable



Terminal release tool

Page 2-1 ~ 2-1



Terminal pliers

Page 2-11 ~ 2-14



Circuit tester tool (AC)

Page 2-21 ~ 2-22



Radio removal tool

Page 2-1 ~ 2-2



Wire stripper tool

Page 2-14 ~ 2-14



Cable cutter tool

Page 2-23 ~ 2-24



Battery tool

Page 2-3 ~ 2-5



Cable stripper tool

Page 2-14 ~ 2-15



Terminal crimping tool

Page 2-24 ~ 2-26



Circuit tester tool (DC)

Page 2-6 ~ 2-11



Insulated tool

Page 2-15 ~ 2-19



12pc Universal terminal release tool set

912C1



- Easy, quick and professional repair of malfunctions due to loose contacts.
- Basic set for about 80% all plug-type connections in passenger cars for damage-free releasing of plug-type connectors, e.g. flat and round connectors.
- Universal application in the field of car electricity.
- 2-coloured plastic handles with foldable caps protecting the blades from damage and avoiding the risk of injury.
- Application: FORD, BMW, MERCEDES BENZ, OPEL, VW, FIAT, MAN, SAAB, RENAULT, DIAMLERCHRYLER, PORSCHE, PSA, SKODA, AUDI, MAZDA, TOYOTA.



10/7.7/8.7/1.1' 770g

Terminal release tool set

923C1



- Designed especially to release terminals from the plastic connectors without damaging them.
- Release terminals on most of the body wiring connectors.
- Applicable: suitable for most vehicles.

12/19.0/20.0/4.0' 1583g

10pc Radio removal tool set

910C1



For : FORD/VW/AUDI;BMW;
NEW BEETLE/AUDI;
MERCEDES-BENZ;
VW;BMW



100/10.2/11.2/0.58' 102g

18pc Radio removal tool set

918C1



- Designed to remove radio easily without damage.
- For VW, FORD, AUDI, GRUNDIG, BLAUPUNKT, BMW, BECKER, MERCEDES-BENZ, PORSCHE, OPEL, SKODA.

100/15.4/16.4 /1.2' 154g

20pc Radio removal tool set

920C1



- Designed to remove radio easily without damage.
- For ALFA, FIAT, VW, FORD, RENAULT, AUDI, GRUNDIG, BLAUPUNKT, BMW, BECKER, MERCEDES-BENZ, PORSCHE, OPEL, SKODA, PEUGEOT.
- For JVC, PIONEER, CLARION.

100/17.5/18.5/1.2' 175g

10pc Mercedes-Benz Dashboard service tool set

910C3



- Removal hooks for instrument cluster on models W107, W116, W123, W124, W126, W140, and W201.
- Removal tools for ignition lock on models W126, W124 & W201.
- Radio removal tool on model W129, W140, W202, and W210.



48/17.9/18.9/3.5' 373g

Bulbs pliers

9G0302



- Special pliers for mounting and dismounting wedge base bulbs.
- Use for most of the car.



120/5/6/2' 42g

Battery terminal & wiper pick-up tool

9C2001



- To work for battery terminals and windshield wipers etc.
- The tight terminals will be lifted off without damage to the battery case or posts because the sharp jaws are able to engage either below or on the sides of terminals.
- The center screw swivel also makes this puller very effective on the alternator bearings.



72/22.9/23.9/2' 320g

Battery terminal / alternator bearing puller

9C2002



- The tight terminals will be lifted off without damage to the battery case or posts because the sharp jaws are able to engage either below or on the sides of terminals.
- The center screw swivel also makes this puller very effective on the alternator bearings.



60/23.6/24.6/1.8' 393g

Battery brush

9U3002



- Designed for cleaning the battery terminals.
- There are two sides for using.

120/9.7/10.7/1.7' 81g

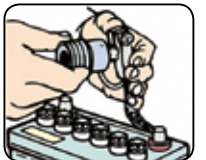
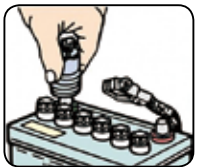

Battery holder

9C2005



- Self locking design with rubber grip pads provide a secure grip on batteries 4-1/2" to 7" width.
- Suitable for top and side terminal batteries.
- Allow one handed lifting of battery in awkward location.
- Heavy duty zinc-plated steel construction for long life.

24/13.0/14.0/1.9' 541g



Auto memory saving kit

9C2008



- Maintains the memory of car radios, clocks and computer functions when battery is disconnected.
- Simply attach a 9-volt battery and plug into cigarette lighter.
- Will retain settings up to 4 hours.
- Will not power any lights or other accessories.

144/10.0/11.0/2.1' 40g



Power backup supply

903C1

NEW



- Special adapter to prevent lose any data from replacing car battery.
- Connect adapter from battery 9V Battery (not Included) or 12V Battery (not included) to OBD II Plug for Continue Power Supply.
- High visibility: LEDs display.



VW cigarette lighter release tool

9C2009

NEW



- Used for removing 12 volt socket.
- Application: Audi A4 2001 / Audi A4 2008/ Audi Q5 2008/ Audi A6 2005/ Audi Q7 2007.

⚖️ 155g

Battery hydrometer tester

9G4005

- Avoid dead battery and thus help to extend battery life.
- Test battery life - hot or cold, and thus help to prevent overcharge.
- Applicable: 6,12,24 volts system.



📦 100/13/15.2/5.8" ⚖️ 130g

Vehicle actuator tester

88435

NEW



- Test electronic components by magnetic field or electronic magnetic field.
- Like actuator, ignition coil, AC generator, indoor air blower, spark plug, relay and hall effect sensor.
- Description: 1. Positive and Negative sensor
2. Two Sensitive Level Indicator: RED LED — Strong; Yellow LED- Weak
3. LED and buzzer indication

Dualite high and low voltage trouble shooter

88421



- Checks 6 and 12 volt system, circuit tester & spark plugs tester (two testers in one.)
- On secondary or high voltage circuits check out spark plugs.
- Checks breaks in radio resistant hook ups.
- Pin point minute cracks in distributor caps.
- Use as a continuity tester and check on low voltage circuits.
- Extra long 48-in leads.

📦 100/5.9/6.9/2.5' ⚖️ 59g

Car light tester

88422



- Checks 6-24V system
- Solid brass body with a test light.
- Prod tip is covered with a brass protective screw cap.
- 850mm cable with an alligator clip on the end.



📦 100/3.6/4.6/2.5' ⚖️ 36g

Car light tester

88423



- Checks 6-24V system
- Solid brass body with a test light.
- Prod tip is covered with a brass protective screw cap.
- 850mm cable with an alligator clip on the end.

100/7.9/8.9/2.5' 79g

Auto battery and charging system analyzer

88424



- Checks 12 volt system
- Auto battery analyzer checks batteries, regulators and alternators.
- With LED indicator that helps pinpoint problems for fast troubleshooting.

200/9.0/10.0/3' 45g



Cordless circuit tester

88425



- Detects from 3 to 28 volts.
- Safe with ECMs, sensors, transducers, airbags, etc..
- No ground wire or clip required.
- Replaceable long-life alkaline batteries included.

60/3.8/4.8/0.78' 63g



Automotive multi-tester

88426



- Voltage, battery, alternator multi-checker for all 12V DC systems.
- With a "Magnetic board" on the back side to fix on suitable metal sheet of car easily.
- 6 LED indicators to show battery charge situation and high or low output of alternator.

48/4.1/5.1/1.3' 86g



Auto tester

88427



- Checks 3-48V
- Circuit tester with test lead for either passenger car or trucks.
- Checks circuit between 3~48 volt.
- LED display shows polarity.

100/8.4/9.4/3.2' 84g



Heavy duty circuit tester

88431



- Checks voltage 6-12-24 V system.
- 5-ft cable with spring relief.
- Tough plastic handle lights up if circuit is good.
- Heavy duty insulated alligator clip.

60/13.4/14.4/3.4' 223g



■ Circuit tester

88432

- Checks 6-12-24V
- 48-in cable with insulated alligator clip.
- Tough plastic handle lights up if circuit is good.



100/9.3/10.3/2' 93g

■ Circuit tester for general & hybrid car

88433

- Compatible with current 12V system plus newer 42V system.
- Safe for low current circuits since tester only draws 3 milliamps at 12V.
- Automatic voltage identification with blue for 12V and red for 42V systems.
- Two super-bright LED's for visibility under all conditions.
- New crystal-clear handle provides 360° visibility, even in bright light.



100/9.3/10.3/3.2' 220g



■ Terminal test kit

919C1

- Terminals include Weather-Pack, Metri-Pack, and Micro-Pack style terminals.
- Use this tester to check high and low voltages (power and ground) on 6~ 24 Volt system.
- Contents:
 - 1pc Circuit Tester, wire length 12 ft.
 - 14pc terminal adapter kit.
 - 1pc Banana socket.
 - 1pc Testing needle.
 - 2pc Alligator.



20/13.0/14.0/1.62' 650g

■ Multi-functional auto circuit tester with LCD display

88444

- Checks from 6V to 24V system with LCD indicator and LED illumination.
- Four modes can be selected by depressing the mode button and cycling through each one.
- Voltage meter
- Locate missing cylinders.
- Measuring rotational speed (Measuring the frequency of the high-tension ignition pulses).
- Peak Detection
- Include a Cigarette lighter adapter, a Hook-up clip, and extension 20ft lead.
- Extension Probe (85mm) included.
- Instruction manual included.



10/11.0/12.0/1.7' 1.1kg



■ Multi-purpose connector set

990C1

- When checking the parts, it could connect the back of terminal directly, would not to damage the circuit or cut the electric wires, reduce the circuit rust and avoid adding impedance.
- Apply to any Automotive Multi-meter, the extended line of probe for oscilloscope. More convenient connection and checking rapidly.
- Variable Resister can simulate the pretend signal of coolant temperature sensor, throttle valve sensor and send the pretend signal to computer.
- Equip 2 sets LED light. It can supervise hall effect, photoelectric signal, nozzle, electromagnetic valve, electromagnetic valve of transmission shift gear... and control signals.
- SRS Connector can simulate airbag and routed contracting device of safety belt to avoid accident or miss-judgment



4/11.2/12.2/2.9' 2850g



ELECTRICAL/
CABLE

13pc Probe and test adaptor set

913C1



- Apply to any Automotive Multi-meter, the extended line of probe for oscilloscope.
- More convenient connection and quicker checking .
- When checking the electric current, only use the lines to connect the circuit, do not need to cut the electric wires.
- Various wires in this box, it is suitable for the Europe, America and Japan terminal.



20/10.3/11.3/1.2' 515g

2pc Insulator pierce-through clip

902C1



- Applicative wire diameter: $\varnothing 1.5 \sim \varnothing 4.5$
- Voltage range : 0V ~ 30V
- Current load : Max. 5 A

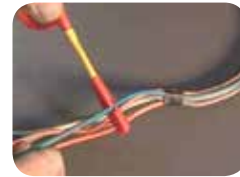

48/5.1/6.1/2' 107g

Ratchet terminal tool kit

68013



- 1pc Terminal pliers.
- 4pc Die nests.
- 1pc Wire stripper.
- 1pc Hex key wrench.
- Crimps insulation, non-insulation & open barrel terminals.
- Built-in ratchet with safety release assures uniform crimp every time.
- It releases and opens automatically when crimping is done.
- Applicable: Insulated Terminal
(0.5-1.0 / 1.5-2.5 / 4.0-6.0 mm²)
Non-Insulated Terminal
(1 / 2 / 4 / 6-10 mm²)
Open Barrel Non-Insulated Terminal
(0.5-1.0 / 1.1-2.5 / 4.0-6.0 mm²)
Cord-End Insulated Terminal
(0.5 / 0.75 / 1.0 / 1.5 / 2.5 / 4.0 mm²)

Terminal pliers red, blue, yellow

6801



- For terminal:

(The terminals are not included.)

30/16.2/17.2/1.5' 540g

Terminal pliers 0.5; 0.75; 1.0; 1.5; 2.5; 4

6802



- For terminal:

(The terminals are not included.)

30/16.7/17.7/1.5' 557g

Terminal pliers 0.5-1; 1.1-2.5; 4-6

6803



- For terminal:

(The terminals are not included.)

30/16.1/17.1/1.5' 535g

Crimp lever pliers

6807



- Suitable for RG58, RG59/62, BNC/TNC coaxial connectors
- Size: 0.256(6.48mm), 0.319(8.13mm), 0.068(1.73mm), 0.213(5.41mm)



30/16.5/17.5/1.5' 550g

■ Terminal pliers 1; 2; 4; 6-10

68015

- For terminal: 
- (The terminals are not included.)





 30/17.14/18.1/1.5'  570g

■ Stripper pliers

6804

- Two functions:
- A cutter & a stripper for electrical cables of 0.2mm² to 3.5mm² in diameter.



 60/14.3/15.5/1.7'  220g





■ Heavy duty stripper pliers

6805

- Cut and strip 10-24 AWG copper or aluminum wire, solid or stranded
- Crimp 10-22 AWG insulated terminals
- Crimp 10-22 AWG non-insulated terminals
- Crimp 7-8 mm ignition terminals



 60/23.4/24.4/2.3'  390g



■ Multi-function stripper pliers

6805A

NEW

- Remove the layer and cut off the wire of AWG 10~AWG 24 (0.2 ~ 6.0 mm²), the tool will not hurt the internal lines and keep the terminal steady.
- Crimp 10-22 AWG (0.5 ~ 6.0 mm²) insulated terminals.
- Crimp 10-22 AWG (0.5 ~ 6.0 mm²) non-insulated terminals.
- Crimp 7-8 mm ignition terminals.





■ Multi-purpose crimping tool

6806

Function:

- Wire cutter
- Crimps insulated terminals
- Bolt cutter
- Crimps non-insulated terminals (open barrel)
- Wire stripper



 40/11.7/12.7/1'  293g





■ Cable, wire stripper

68011

- Remove the layer and cut off the electrical cable
- For wire 0.8~2.6 mm
- Cable stripper for the wire under 9.5mm



 200/25.5/26.5/3.1'  125g





■ Cable Stripper

6808

- Able to strip cable up to 4mm - 28mm(dia.).





 100/10.0/11.0/1.8'  100g

■ Cable Stripper

6809

- Able to strip cable up to 8mm - 28mm(dia.).



 100/11.0/12.0/2.1'  100g

■ Cable Stripper

68010



- Able to strip cable up to 4.5mm - 25mm(dia.).

100/12.5/13.5/2' 220g

■ Telecrimper

68012



- Cuts, strips & crimps integral in one tool.
- With built-in length stop for precisely length stripping.
- 2 crimp functions with a single tool without changing dies.
- Advanced ratchet system.
- Precision CNC grounded crimping teeth.
- Crimp RJ45 & RJ11 Modular plugs.



48/19.0/20.0/1.5' 400g

■ 31pc 3/8" DR. Insulated combination set

3313N



Contents:

- 12pt. Flank insulated socket
6; 7; 8; 9; 10; 11; 12; 13; 14; 15; 16; 17; 18; 19 mm
- Insulated combination wrench
7; 8; 10; 12; 14 mm
- Insulated extension 150, 250 mm
- Insulated ratchet handle
- Screwdriver probe voltage tester 110~250V AC
- Insulated combination pliers 7"
- Insulated long nose pliers 6"
- Insulated diagonal cutting pliers 6"
- Insulated Phillips screwdriver PH.1(80mmL); PH.2(100mmL)
- Insulated Slotted screwdriver 2.5(75mmL); 4(100mmL); 5.5(125mmL)

3/11.9/12.5/1.5' 4000g

■ 17pc Insulated socket set

3173N



- 12pt socket
6, 7, 8, 9, 10, 11, 12, 13, 14, 15, 16, 17, 18, 19 mm
- Extension 150, 250 mm
- Ratchet handle

10/21.0/21.8/1.8' 2100g

■ 3/8" DR. Insulated torque wrench

6473268N



- 6473268N:3/8"DR.5-25Nm

12/20.4/21.2/1.12' 1700g

■ 3/8" DR. 12pt. Flank insulated socket

539N



Part no.	Size mm	l mm	g
53906N	6	43	28
53907N	7	43	30
53908N	8	43	30
53909N	9	43	30
53910N	10	43	30
53911N	11	43	30
53912N	12	44	30
53913N	13	44	31
53914N	14	44	38
53915N	15	44	47
53916N	16	46	47
53917N	17	46	54
53918N	18	46	58
53919N	19	46	61

■ 3/8" DR. Insulated extension

8043N



Part no.	l mm-inch	g
8043150N	150-6"	160
8043250N	250-10"	260

■ 3/8"DR. Insulated ratchet handle(45 teeth)

802320N

- Length:200mm
- Weight:354g



■ 3/8"DR. Insulated extension T handle

7743200N

- Drive:3/8"
- Length:207mm
- Weight:400g



■ Insulated open end wrench

829



Part no.	Size	<i>l</i>	
	mm	mm	g
82907	7	89	20
82908	8	99	26
82910	10	114	40
82912	12	134	61
82914	14	155	96
82917	17	190	147

■ Insulated 75° offset ring wrench

829A



Part no.	Size	<i>l</i>	
	mm	mm	g
829A07	7	147	52
829A08	8	156	62
829A10	10	167	73
829A12	12	188	90
829A14	14	199	135

■ Fully insulated adjustable wrench

649M



Part no.		<i>l</i>	
	packing	mm	g
649M200	40/13.6/16.5/1.2'	200	320
649M250	24/15.4/16.9/1.1'	250	640
649M300	16/16/17.5/1.05'	300	980

■ Insulated adjustable wrench

649N



Part no.		<i>l</i>	
	packing	mm	g
649N200	64/18.2/19.2/0.81'	200	285
649N250	32/16.6/17.6/0.7'	250	520
649N300	16/15.4/16.9/1.1'	300	920

■ Insulated knife

830



83001



83002

Part no.	Shape	<i>l</i>	
		mm	g
83001	Straight	150	145
83002	Curved	150	148





2182N

18pc Insulated screwdriver & pliers set

- Insulated Phillips screwdriver PH.0(60mmL); PH.1(80mmL); PH.2(100mmL); PH.3(150mmL)
- Insulated slotted screwdriver 2.5mm(75mmL); 3mm(100mmL); 3.5mm(100mmL); 4mm(100mmL); 5.5mm(125mmL); 6.5mm(150mmL); 8mm(175mmL)
- Insulated combination pliers 7"
- Insulated long nose pliers 8"
- Insulated diagonal pliers 8"
- Insulated wire stripper pliers 6"
- Insulated cable cutter 6"
- Multi-purpose crimping tool
- Universal voltage tester Testing range: 6~400V AC/DC



3262

26pc 3/8" DR. Insulated socket set

- Contents:
- 12pt. Flank insulated socket 6; 7; 8; 9; 10; 11; 12; 13; 14; 15; 16; 17; 18; 19 mm
 - Insulated combination wrench 7; 8; 10; 12; 14 mm
 - Insulated extension 150, 250 mm
 - Insulated ratchet handle
 - Insulated T-handle
 - Insulated torque wrench 5~25 Nm
 - Insulated cable knife (straight)
 - Insulated cable knife (curve)

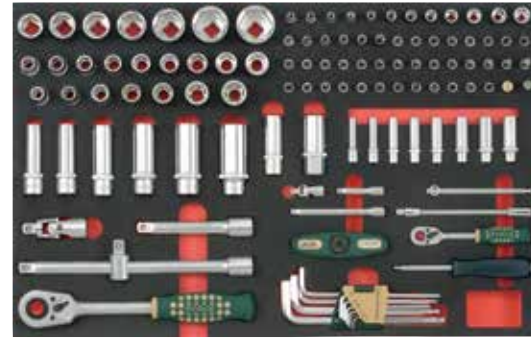

41161

116pc 1/4" & 1/2" DR. Socket set

- Contents: 1/4" & 3/8" & 1/2"DR.
- 1/4" part
 - 6pt. Flank socket 4; 4.5; 5; 5.5; 6; 7; 8; 9; 10; 11; 12; 13 mm
 - 6pt. Flank deep socket (50mmL) 6; 7; 8; 9; 10; 11; 12; 13 mm
 - Star socket E4; E5; E6; E7; E8; E10
 - Socket bit (32mmL)
 - Phillips PH.0; PH.1; PH.2; PH.3
 - Pozidriv PZ.0; PZ.1; PZ.2; PZ.3
 - Slotted 3; 4; 5.5; 6.5 mm
 - Hex 3; 4; 5; 6; 7; 8; 10 mm
 - Star T8; T10; T15; T20; T25; T27; T30; T40
 - Star tamper T-8H; T-10H; T-15H; T-20H; T-25H; T-27H; T-30H; T-40H
 - 20 teeth ratchet handle
 - 48 teeth T mini ratchet handle
 - Sliding T handle
 - Extension 2" & 4"
 - Flexible extension 145mmL
 - Spinner
 - Universal joint
 - Magnetic socket pick-up
 - 1/2" part
 - 6pt. Flank socket 10; 11; 12; 13; 14; 15; 16; 17; 18; 19; 21; 22; 24; 27; 30; 32 mm
 - 6pt. Flank deep socket 14; 15; 17; 19; 22; 24 mm
 - Star socket E12; E14; E16; E18; E20; E22; E24
 - 36 teeth ratchet handle
 - Extension 5" & 10"
 - Universal joint
 - Adaptor for ext. 3/8"(F)x1/2"(M)
 - Spark plug socket 16; 20.6mm
 - Others:
 - Hex ball point long key 1.27; 1.5; 2; 2.5; 3; 4; 5; 6; 8; 10mm

■ **10217-266**

■ **10217A-266**

■ **10217B-266**

■ **10217R-266**

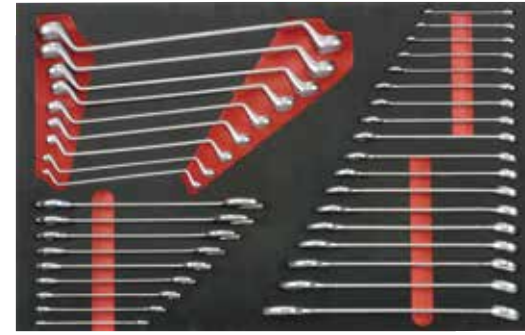

5363

36pc Automotive essential wrench set

- Double open end wrench 6x7; 8x9; 10x11; 12x13; 14x15; 16x17; 18x19; 20x22; 21x23 mm
- Combination wrench 6; 7; 8; 9; 10; 11; 12; 13; 14; 15; 16; 17; 18; 19; 20; 21; 22; 24 mm
- 75° offset ring wrench 6x7; 8x9; 10x11; 12x13; 14x15; 16x17; 18x19; 20x22; 21x23 mm



51610

16pc Pliers set

- Round nose pliers 5"
- Flat nose pliers 5"
- Combination pliers 5"
- Long nose pliers 5"
- Needle nose pliers 6"
- Bent nose pliers 6"
- Cutter pliers 6"
- Diagonal pliers 6"
- Circlip pliers
- External straight tip 1.8mm for opening
- Internal straight tip 1.8mm for closing
- External 90° Bent tip 1.8mm for opening
- Internal 90° bent tip 1.8mm for closing
- 4-in-1 Electrical pliers 6"
- Diagonal cutting pliers 6"
- Cable cutter 10"
- Plastic cutting pliers 6"



5212

21pc Utility set

- Utility knife (3pcs blade incl.)
- 5m measuring tape
- Chisel 12mm (150mmL)
- Ribbed chisel 21mm (150mmL); 26mm (200mmL)
- Cape chisel (150mmL)
- Pin punch 2mm (140mmL); 3mm (150mmL); 4mm (190mmL); 5mm (200mmL); 6mm (210mmL); 8mm (215mmL)
- Tape punch 3mm (185mmL)
- Center pinch 4(185mmL)
- Engineer hammer 300gw
- Rubber hammer 400gw
- 3-in-1 Magnetic flexible pickup tool
- 26 sizes Feeler gauges (SAE & Metric)
- LED white light, clip-type (360° rotation)
- Technician's scissors 145mmL
- Gasket scraper



4341

34pc 1/2" DR. Impact socket & Wheel nut tools

- 6pt. Flank impact socket 10; 11; 12; 13; 14; 15; 16; 17; 18; 19; 21; 22; 23; 24 mm
- 6pt. Flank impact deep socket 10; 12; 13; 14; 16; 17; 19; 21; 22; 24 mm
- Wheel nut 6pt. Flank impact socket (colored) 17; 19; 21; 22 mm
- Impact wrench
- Impact extension 5"
- Universal joint (ball type)
- 1/2" Torque wrench
- Foldable cross-handle socket wrench 17; 19; 21; 1/2" square (16"L; 400mmL)
- Wheel balancing weight tool

Induction circuit tester

2125P1

- Non-contact wire tracer



100/2.6/3.6/1.6' 26g

Screwdriver probe voltage tester

88401

- Testing range: 110~250V AC.
- Length: 140mm



200/6.5/7.5/4.6' 33g



Screwdriver probe voltage tester

88402

- Testing range: 110~250V AC.
- Length: 190mm



200/9.6/10.6/4.6' 48g

Screwdriver probe voltage tester

88403

- Testing range: 110~250V AC.
- Length: 155mm



200/10.0/11.0/4.6' 50g



Screwdriver probe voltage tester

88404

- Testing range: 110~250V AC.
- Length: 190mm



100/6.8/7.8/4.6" 68g



Adjustable non-contact wire tracer

88407

- Testing range: 12~600V AC 50~60HZ.
- Locates breaks along live, insulated wires and power cords.
- Adjustable sensitivity allows tracing of wires behind walls, around switches or receptacle.
- Easy to recognize by audio signal and LED indicator.
- Operates by two LR44, 1.5V batteries included.



100/5.4/6.4/1.3' 54g



Universal voltage tester

88408

- Testing range: 6~400V AC / DC.
- This voltage tester is designed for industrial purposes and hobbyists and is suitable for domestic voltage and heavy current circuits.
- Display: ± 6, 12, 24, 50, 120, 220
400V AC / DC=LED
(ED): 30sec
I max: 30mA



60/8.5/9.5/2.7' 142g



■ Cable cutter

6926315

- For cutting copper and aluminum cable up to 100 mm².
- Length: 315 mm.



20/14/15.5/1.4' 700g

■ Cable cutter

6926600

- For cutting copper and aluminum cable up to 250 mm².
- Length: 600 mm.



10/17/20.5/2.2' 1700g

■ Cable cutter

6926800

- For cutting copper and aluminum cable up to 500 mm².
- Length: 800 mm.



5/14.5/17/1.66' 2900g

■ Ratcheting cable cutter

6926R255

- For cutting copper and aluminum cable up to 325 mm².
- Length: 255 mm.



30/20/21.7/2' 667g

■ Ratcheting cable cutter

6926R280

- For cutting copper and aluminum cable up to 500 mm².
- Length: 280 mm.



20/19.6/21.6/1.2' 980g

■ Ratcheting cable cutter

6926R400

- For cutting copper and aluminum cable up to 500 mm².
- Length: 400 mm.



15/18.4/19.4/1.86' 1227g

■ Terminal crimping tool

68051

- Copper tube terminal range: 1.5, 2.5, 6, 10 mm². (DIN)
- Non-insulated terminal range: 1.25, 2, 5.5, 8 mm². (JIS)
- Length: 270 mm.



30/14.4/18/1.4' 480g

■ Terminal crimping tool

68052

- Copper tube terminal range: 1.5, 2.5, 6, 10, 16 mm². (DIN)
- Non-insulated terminal range: 1.25, 2, 5.5, 8, 14 mm². (JIS)
- Length: 298 mm.



30/15.6/19.4/1.4' 520g

■ Terminal crimping tool

68053

- Copper tube terminal range: 6, 10, 16, 25 mm². (DIN)
- Non-insulated terminal range: 5.5, 8, 14, 22 mm². (JIS)
- Length: 354 mm.



30/23/28/1.66' 767g

■ Terminal crimping tool

68055

- Copper tube terminal range: 6, 10, 16, 25, 38 mm². (DIN)
- Non-insulated terminal range: 5.5, 8, 14, 22, 50 mm². (JIS)
- Length: 375 mm.



25/22/26/2.1' 880g

■ Terminal crimping tool

68056

- Copper tube terminal range: 16,25,50,70,95 mm². (DIN)
- Non-insulated terminal range:14,22,38,60,80 mm². (JIS)
- Length:660 mm.



5/17.7/19.4/1.14' 3540g

■ Terminal crimping tool

68057

- Copper tube terminal range:10,16,25,35,50,70,95,120 mm². (DIN)
- Non-insulated terminal range:8,14,22,38,60,70,80,100 mm². (JIS)
- Length:573 mm.



5/15/16.4/0.64' 3000g

■ Terminal hexagonal crimping tool

68071

- Copper tube terminal range:10,16,25,35,50,70,95,120 mm². (DIN)
- Length:650 mm.

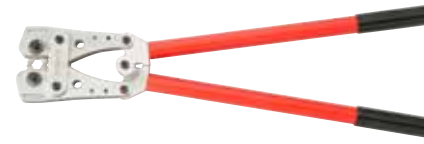

5/15.5/17.5/1.9' 3100g

■ Terminal hexagonal crimping tool

68072

- Copper tube terminal range: 25,35,50,70,95,120,150 mm². (DIN)
- Length:650 mm.



5/15.5/17.5/1.9' 3100g

■ Hydraulic terminal crimping tool

68081

- Designed to accommodate hexagonal, dies of hydraulic tools for applying compression fittings to copper conductors.
- Copper tube terminal range:50 ~ 400 mm²
- Accessories:50,70,95,120,150,185,240,300,400 mm².
- Crimping force:12T



3. Brake / Transmission



Brake tool
Page 3-1 ~ 3-15



Axle puller tool
Page 3-34 ~ 3-35



Shock absorber tool
Page 3-47 ~ 3-52



Camber adjustment tool
Page 3-65 ~ 3-65



Wheel tool
Page 3-16 ~ 3-26



Vibro chisel tool
Page 3-36 ~ 3-36



Propeller shaft tool
Page 3-53 ~ 3-57



Transmission tool
Page 3-66 ~ 3-68



Axle bush/wheel hub tool
Page 3-26 ~ 3-32



Ball joint tool
Page 3-36 ~ 3-45



Oil drain machine / tank
Page 3-58 ~ 3-63



Jack
Page 3-69 ~ 3-69



Bearing race / Seal driver tool
Page 3-32 ~ 3-33



Tie rod tool
Page 3-45 ~ 3-46



Tailpipe tool
Page 3-64 ~ 3-65



6pc Brake spanner set

50612



Contents:

- 6-Brake spanner
- 6080610 1/4"Sq. - 10mmSq.
- 6080608 1/4"Sq. - 5/16"OE
- 6080810 8mmHex - 10mmHex
- 6080911 9mmHex - 11mmHex
- 6080607 1/4"Hex - 7mmHex
- 6081109 7/16"OE - 11/32"Sq.

30/17.8/18.8/1.3' 593g

Brake spanner

608



Part no.	Size	<i>l</i> mm	 g	 pc/box
6080610	1/4"Sq.-10mmSq.	175	82	10
6080608	1/4"Sq.-5/16"OE.	175	84	10
6080810	8mmHex.-10mmHex.	175	82	10
6080911	9mmHex.-11mmHex.	175	87	10
6080607	1/4"Hex.-7mmHex.	175	84	10
6081109	7/16"OE.-11/32"Sq.	175	85	10
6081114	7/16"OE.-9/16"OE.	175	102	10
6081113	11mmOE.-13mmOE.	175	103	10
6081011	10mmOE.-11mmOE.	175	92	10

Drum brake spring pliers

9B0101



- One end hooks on the spring, the floating cap with hooks grips.
- On the lining fastened to the brake shoe.
- Use for two brake return spring system.
- Can use for most of the commercial and industrial vehicles.



36/18.0/19.0/2.5' 500g

Brake spring pliers

9B0102



- Designed by professional mechanics to remove and replace springs.
- Thin narrow points with "Straight-In-Line" pull on spring.
- Includes special socket for application on all hydraulic brakes.



24/9.8/10.8/1.6' 410g

Handbrake cable spring pliers

9B0104



- For compression of the retaining spring on the handbrake cable.
- This tool allows quick and problem-free removal and installation of the handbrake cable.
- Application: VW, AUDI, BMW, CITROEN, NISSAN, PEUGEOT, RENAULT, ROVER, SEAT, etc.



72/16.4/17.4/1.6' 230g

Drum brake spring pliers

9B0105



- Designed to remove the brake return spring. One end grips on the brake lining and the other hooks on the spring.



72/20.0/21.0/1.2' 280g

Headlight adjusting and brake spring hook

9B0304



- This tool made from heat-treated alloy steel is especially designed for removing and installing hard-to-reach headlight adjusting and brake springs.



120/9.0/10.0/1.7' 75g

■ Brake spring washer pliers

9B0107



- Universal application for nearly all drum brakes.
- Special neck angle provides easy removal and installation of brake spring washer.
- Length:180.5mm.
- Heat treatment:HRC43°~46°.
- Max Angle:50°.



40/10.0/11.0/1.05' 250g

■ Brake spring pliers

9B0109

NEW



- To remove or install the brake shoes, the brake shoe retaining spring must be pre-tensioned.
- Suitable for Mercedes A-Class, Citroen, Renault, Peugeot with Lucas drum brake on the rear axle. Also used on Land Rover, Ford, Honda, etc.



72/18.5/19.5/1.6' 230g

■ Brake spring tool

9B0108

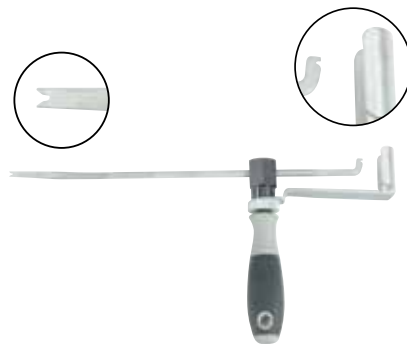

- Universal application of both removal and installation for nearly all drum brakes.
- Wide angle application.
- Length:310mm.
- Heat treatment:HRC42°~45°.



20/9.5/10.5/2.0' 375g

■ Retainer spring compressor

9T0202



- Allow fast & easy removal & replacement of brake shoe hold-down springs.



96/17.0/18.0/2' 150g

■ Retainer spring tool

9T0203



- For removal and installation of retaining springs on such drum brakes where the brake pads are not fixed onto the anchor plate.
- Therefore the retaining spring will be inserted into the hook head of the tool and will be tightened by winding the handle.
- The installation happens by pulling the retaining spring with the tool into the correct position.



72/7.3/8.3/1.3' 101g

■ 4pc Drum brake piston locking pliers set

904B1



- Set of four pliers for locking drum brake pistons.
- Both ends hold pistons in cylinders, making it easier to replace jaws.
- When the drum brake is taken off, it can prevent the piston oil from returning and thus avoid the piston damage.



48/16.5/17.5/3' 344g

■ Brake shoe adjuster tool

9B1701



- Can be used for most of cars.
- Make adjusting easy even for strong springs.



100/19.0/20.0/2' 190g

8pc Manual brake gauge set

908B2



- The brake gauge tool is designed to give customers an accurate measurement of how much brake lining is left without guess work.
- Most state agencies require that the customer be notified of how much brake lining is left in order to suggest that the lining should be replaced.
- The technician must refer to the OEM manufacturer specifications to determine if the lining is worn below minimum specifications.
- Size including:
 Red (Bad): 2mm (0.0787") ; 3mm (0.1181")
 Yellow (Dangerous): 4mm (0.1575") ; 5mm (0.1969") ; 6mm (0.2362")
 Green(Good): 8mm (0.3150") ; 10mm (0.3937") ; 12mm (0.4724")



72/18.0/19.0/1.7' 250g

Brake lining gauge

9B1801



- Measures brake lining from 0 to 1/2" in 1/64" graduations.
- Instructions:**
- Apply jaws to brake shoe. Keeping jaws on shoe, move the indicator arrow to "O". This will automatically subtract the shoe thickness from the total measurement.
- Apply jaws to shoe and lining. The arrow will indicate the amount of lining remaining.



72/12.5/14.0/1.5' 173g

Tire tread and brake lining gauge

9B1802



- Used to measure the amount of lining remaining on riveted and bonded drum shoes and disc brake pads.
- Measures tire tread depth up to 9/16" in graduations of 1/64".
- Checks pads without having to remove caliper completely.



120/12.0/13.0/1.1' 100g

Brake shoe adjustment gauge

9T0107

NEW



- Measures clearance between brake drums and shoes with diameters from 160mm to 400mm.
- Works on most small cars with drum brake prior to assembly.
- Inside calipers measure drum diameter.
- Outside Calipers transfer measurement to brake shoes.

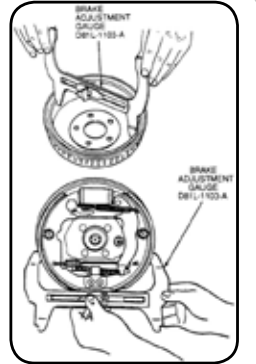

96/17.0/18.0/2' 150g

Gauge for brake disc depth & tire tread

9T0106



- Handy, easy to use.
- Special device to fix the value you obtain while measuring the thickness of brake disc.
- Brake disc measure range: 0 ~ 60mm.
- Measure tyre depth.
- Aluminum made.



48/12.0/13.0/1.2' 250g

Tire tread depth gauge with led buzzer reminder

9B1803

NEW



- This is a new design tire tread depth gauge, it has indicator bar that calibrated for measurement.
- The contact tip is profiled to work in narrow spaces between tread.
- That can warning the tire tread depth is not enough to keep using this tire and you'll hear the "beep" and led will light, so you can easy to know the tire tread depth is good or not.
- You can set the gauge that you'd like to measuring calibration, then put the tip to tire tread, it's easier to know the tire tread depth, and you don't stoop and read the gauge hard.



48/12.0/13.0/1.2' 250g

Brake air-leaking valve

9B3501



- Designed to release air bubbles inside slave cylinder after replacement to make safe, efficient braking.



60/4.6/5.1/0.58' 70g

Brake fluid tester and bleeder tool set

906T7

NEW



- Ideal for bleeding brake system and hydraulic clutch system without removing the wheels.
- Contents :
4pc Brake bleeder wrench 8mm, 9mm, 10mm, 11mm
1pc 1.2M silicon hose with check valve
1pc Brake fluid tester



Brake fluid tester

88502



- To check the quality of brake fluid.
- 5 LED to indicate percentage of water in the brake fluid.
- Application: Brake fluid DOT 4
- LED display:
Green: Battery OK/NO water is detected.
Green/Yellow: Less than 1% of water.
Green/Yellow/Yellow: Approx 2% of water.
Green/Yellow/Yellow/Red: Approx 3% of water.
Green/Yellow/Yellow/Red/Red: At least 4% of water.



100/7.0/8.0/1.5' 70g

Brake fluid tester

88503

NEW



- To check the quality of brake fluid.
- 5 LED to indicate percentage of water in the brake fluid.
- Suitable for DOT3, DOT4, DOT5.1 and 5 different brands: AC Delco, PENNZOIL, Prestone, Motorcraft, TOYOTA.
- LED display : Green: Battery OK/NO water is detected.
Green/Yellow: Less than 1% of water.
Green/Yellow/Yellow: Approx 2% of water.
Green/Yellow/Yellow/Red: Approx 3% of water.
Green/Yellow/Yellow/Red/Red: At least 4% of water.

Master cylinder pressure test kit (brake & clutch)

914B2



- Verify master cylinder operation.
- You can check the following problems : bypassing and internal leaks, restricted compensating ports, improper push rod adjustment and power booster problems.
- One 0-3,000 PSI gauge, 11pc adaptors, one 90° elbow fitting, one 45° elbow fitting.



6/8.7/9.7/2.6' 1440g

Deluxe brake pressure test kit

924B2



- Kit contains a complete set of fittings and gauges for pressure testing ABS and conventional brake systems on Chrysler, Ford, GM, Jeep, and import vehicles.
- Dual scale dial-standard scale 0-3,000 psi and metric scale 0-200 kg/cm2. 4,500 psi rated pressure hose assembly.
- Includes 20-piece adaptor, one 90° elbow fitting, one 45° elbow fitting.

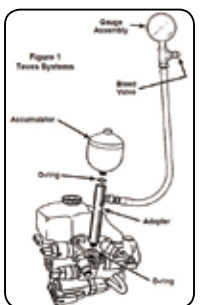

3/10.1/11.1/1.5' 3370g

■ Brake calliper guidance thread repair set

914B1



- For repairing the guide pin threads in the wheel bearing housing.
- With disassembly of guide pins while changing the brake pads the internal threads are frequently destroyed.
- The defective threads are repaired professionally and quickly with a heavy duty rustproof high-grade steel threaded bush.
- Applicable: VW, AUDI



36/17.0/18.0/1.2' 470g

■ 5pc T-handle with reamer for ABS sensor

905T9



- A specifically-designed reamer set complete with 1/4" Drive T-bar handle and complete with 4 popular-sized reamers.

Reamer size:

14 x 42.5L BMW E38/E39/E52/E60/E61/E63/E64/E65/E66/ E67/E70/E71

15 x 33.5L Mercedes Benz A-class, Mazda ,TOYOTA and Ford

18 x 31.5L VW, AUDI, SEAT, SKODA, BMW E36+E46

18 x 42.5L VAG and NFZ



48/12.0/13.0/1.2' 250g

■ 3pc 1/2"DR. Pentagon socket set

4036



- 1-Pentagon socket bit 10mm (55mmL)(65001)
- 2-Pentagon socket:14; 19 mm(65014, 65019)
- For using on grling and bendix brake systems.
- Application:Opel / Vauxhall (Astra G, Zafira), Smart , Ford, Mazda, Peugeot, Renault

60/14.8/15.8/0.5' 246g

■ 1/2"DR. Pentagon socket 14mm / 19mm

65014 / 65019



- 14mm : for pentagon brakes on rear brake, Opel Astra G, Zafira, Smart
- 19mm : for Bendix brakes, Citroën, Peugeot, Renault

■ 1/2" Pentagon socket bit 10mm side

65001



- Application on girling brakes.

Part no.	bit	l mm	g	pc/box
65001		55	94	10

■ Calipers brake pad screw socket for PORSCHE & AUDI

9B0402



- NEW** • 1/2" DR x 16mm x 38mm L (10 point)
- For removal of the calipers brake pad screw for Porsche Cayenne/Audi Q7



50g

■ Brake caliper file

65816



- NEW** • For removing dust, rust and dirt from brake Calliper groove.
- width: 10 mm
- Length: 270 mm

Disc brake pad spreader

9B0401



- Designed for quick and easy changing of disc brake pads.
- Spreader will compress inner pad and reset piston for easy pad replacement in heavy-duty construction.



24/7/8/2'

245g

Disc brake adjuster

62901



Fits in brake caliper to push back pistons for new brake pads installation.



20/22.1/23.1/1.3'

1100g

Disc brake piston compressor (4 pistons)

62902



- Special wider pusher design to use on 4 pistons vehicle.
- Max. working range: 88mm
- Applicable: BENZ, BMW, and 4 pistons vehicle.

8/13.4/14.4/1.1'

1675g

Brake piston wind back pads

903B1



- Brake pad range: 0 ~ 100 mm.
- The pad open jaw: 10 ~ 90 mm.

24/7/8/2'

245g

2&3 Pin brake piston rewind tool (clockwise/counterclockwise)

907B1

NEW



- This tool kit allows you to rewind the pistons in brake calipers.
- It does this by allowing the rotation of the piston at the same time as pushing the piston back into the caliper.
- Spindle Spanner for right and left according to the Factory Operation.
- The correct parts to fit nearly all cars including Alfa Romeo, Audi, Citroen, Ford, Honda, Jaguar, Land Rover, Mazda, Mercedes, Mini, Mitsubishi, Nissan, Lancer, TOYOTA, VW, VOLVO, VAUXHALL and others!

3pc Brake adaptor set (adjustable)

65821

NEW



- Two adjustable brake caliper rewind adaptors - 2 pin and 3 pin.
- Includes magnetic 2 pin drive to 3/8"DR. adaptor.
- Adjustable 2 pin adaptor fits 100s of cars.
- Adjustable 3 pin adaptor only to be used with Electronic Park Brake (EPB) tools.
- Applications include: Audi, BMW, Iveco Daily, Renault, Range Rover Evoque, Seat, Volkswagen, Volvo



48/15.2/16.2/0.84'

316g

Brake caliper rewind tool kit

909T6

NEW



- Professional reset of the rear axle and front axle brake pistons.
- Contents :
 - 1pc Two ways speedy brake adaptor driver
 - 1pc 3 pins adjustable brake adaptor (rear axle)
 - 1pc 2 pins adjustable brake adaptor (rear axle)
 - 1pc Pressure turn device
 - 1pc Reaction plant
 - 1pc Brake adaptor (front axle)
 - 3pc Brake caliper pin punch 4; 5; 6 mm

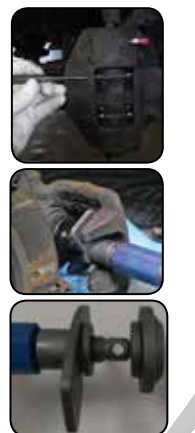

Disc brake service kit

912T6

NEW



- Contents :
- 1pc Two ways speedy brake adaptor driver
- 1pc 3 pins adjustable brake adaptor (rear axle)
- 1pc 2 pins adjustable brake adaptor (rear axle)
- 1pc Pressure turn device
- 1pc Reaction plant
- 1pc Brake adaptor (front axle)
- 3pc Brake caliper pin punch 4; 5; 6 mm
- 1pc Flat file for brakes
- 1pc Magnetic base
- 1pc Dial gauge
- 1pc Gauge for brake disc depth



27pc Brake piston wind-back set

927B1



- This tool has been designed to drastically reduce the time taken when dismantling brakes.
- Will not mark or damage the working part of piston.
- Removes frozen pistons with ease.
- Applicable: ALFA ROMEO, CITROEN, FIAT, VW, AUDI, FORD, ROVER, LINCOLN, NISSAN, SUBARU, HONDA, BMW, MITSUBISHI, TOYOTA, PEUGEOT, OPEL, RENAULT, JAGUAR, MAZDA, VOLVO, VAUXHALL, SAAB, LANCIA

6/26/27/1.7' 4340g

7pc Brake caliper piston tools set

658

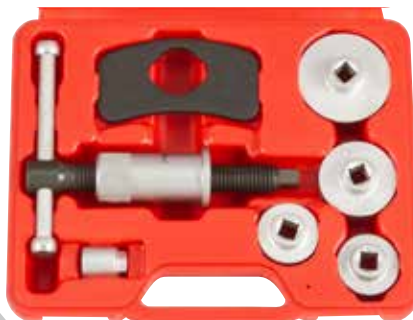

- Kit comprises main body, screw assembly, special locating plate and 5 adaptors covering wind-back.
- Applicable: VW, AUDI, FORD, PEUGEOT, ROVER, NISSAN, SUBARU, HONDA, BMW, MITSUBISHI, TOYOTA, JAGUAR, MERCEDES, MAZDA.

12/16.3/17.3/1.3' 1360g



13pc Disc brake park caliper tools set

65802

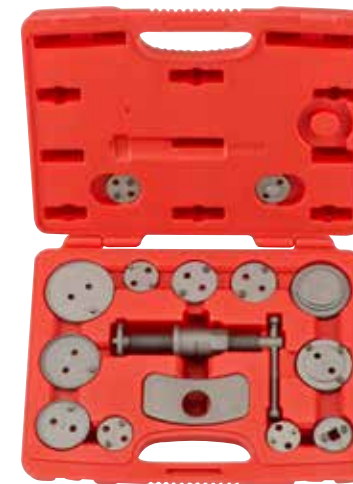

- For rotating pistons back into the caliper to provide clearance for new pads. Include 11 adaptors (available individually) for use in both 2 and 4-wheel rear disc brake assemblies of most domestic and import cars. The tool may be used "on" and "off" the car.
- Suitable for: MERCEDES, BMW, VW, GM, AUDI, FORD, HONDA, SUBARU, MAZDA, NISSAN, MITSUBISHI, TOYOTA, ROVER, 4WD, OPEL, RENAULT.



10/20.1/21.1/1.8' 2kg

18pc Universal caliper wind back kit

65805

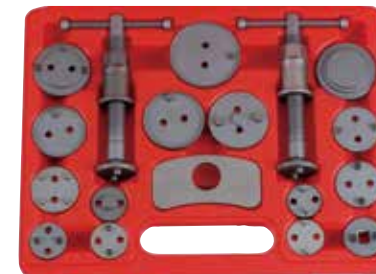

- Two bodies with positive thread and negative thread for different vehicles.
- With one plate and fifteen adaptors to fit most of the cars.
- Applicable: Citroen, AUDI, FIAT, FORD, ISUZU, HONDA, JAGUAR, BMW, NISSAN, MITSUBISHI, VW, SAAB, MAZDA, TOYOTA...etc.



10/25.5/26.5/1.87' 2417g

16pc Air powered brake caliper wind back tool set

65815



- Air Pressure: The range of normal using pressure is 5 ~ 8 kg/ m²; maximal using pressure is 14 kg/m².
- Applicable: Citroen, AUDI, FIAT, FORD, ISUZU, HONDA, JAGUAR, BMW, NISSAN, MITSUBISHI, VW, SAAB, MAZDA, TOYOTA...etc.



5/15.7/16.7/2' 3140g

■ Brake caliper tool

65803



- For rewinding the piston in all collets type disc brake calipers with built-in parking mechanism.
- Essential for fast and easy pad replacement and caliper servicing.
- Suitable for: FORD, HONDA, JAGUAR, MAZDA, MITSUBISHI, NISSAN, ROVER, SUBARU, TOYOTA, with ABS.



30/21/22/0.9' 700g

■ Disc brake park caliper tool

65804



- This tool set is a "must" when installing new brake pads on vehicles with 4 wheel disc brakes.
- Rotate the tool on the parking brake actuator to retract the piston.
- Works on most GM vehicles with 1 1/2" brake pistons, most Ford vehicles, Pontiac Fiero, and imported vehicles.



24/16.6/17.6/3' 691g

■ Universal caliper piston remover

907T3



- Quick change design for 3 sizes of adapter
- Rang from 25mm to 35 mm
- Adapter a. range from 35mm to 45mm.
- Adapter b. range from 45mm to 55mm.
- You can easily take out the piston with assistant handle.



18/18.0/19.0/1.8' 1000g

■ Rim wrench

677



Part no.	Size	<i>l</i> mm	 g	 pc/box	O.D. mm
6771921	19x21	300	1000	5	16
6771924	19x24	300	1020	5	16
6772123	21x23	300	1100	5	16
6772224	22x24	400	1300	5	19
6772427	24x27	400	1320	5	19
6772432S	15/16x1-1/4	400	1330	5	19
6772730	27x30	400	1330	5	19
6772732	27x32	400	1380	5	19
6772733	27x33	400	1400	5	19
6772833	28x33	400	1410	5	19
6773032	30x32	400	1440	5	19
6773033	30x33	400	1440	5	19
6773233	32x33	400	1495	5	19
6773238	32x38	400	1535	5	19
6773821	38x21sq.	400	1520	5	25
6773822	38x22sq.	400	1520	5	25
6774121	41x21sq.	400	1550	2	25
6774121L	41x21sq.	450	1800	1	25

■ Wrench bar

677



Part no.	O.D.	<i>l</i> mm	 g	 packing
67701	19mm	630	1400	15/21/22/0.32'
67702	25mm	630	2420	10/24/25/0.32'
67701400	19mm	400	890	25/22/23/0.2'
67703	16mm	400	630	30/18.9/19.9/0.2'

■ Foldable cross-handle socket wrench

681



Socket size: 17mm; 19mm; 21mm; 1/2" square

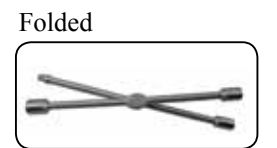

Part no.	 packing	<i>l</i> length	 g
681400	12/17.9/18.9/1.2'	16"(400mm)	1490
681500	10/17.6/18.6/1.1'	20"(500mm)	1760

Assembly wheel nut wrench

681A300

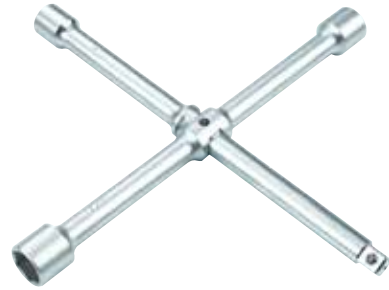

- 17mm; 19mm; 13/16"; 1/2"DR. (300mmL)
- Chrome vanadium alloy steel
- For most car wheel nuts in metric
- Polished, chrome plated



20/22.2/23.2/0.63' 1110g

Wheel nut wrench

681B400



- 17; 19; 21; 22 mm with 1/2"DR. Adapter (400mmL)
- Chrome vanadium alloy steel
- For most car wheel nuts in metric
- Polished, chrome plated



12/18.6/19.6/0.97' 1550g

1/2"DR. Quick power wheel nut ratchet handle

681D515



- Removes stubborn wheel nuts quickly and easily.
- Torque multiplier increases torque by 3.5 by using the lever arm.
- The lever arm should never be used to tighten nuts due to the possibility of over tightening.
- Length: 515 mm



10/23.0/24.01.1' 2300g

9pc Wheel specialized torque tool set

64707

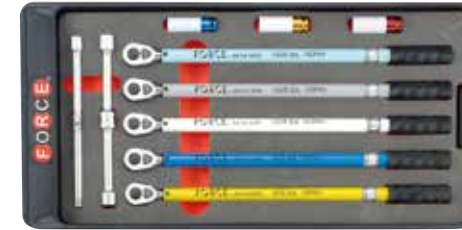

Content: 1/2" DR.
6474 088N...190N 5- Torque wrench
88; 108; 135; 163; 190 Nm

44585 17C...21C 3-Wheel nut 6pt. flank impact socket (85mmL)
17; 19; 21 mm

681A300 1-Assembly wheel nut wrench
17; 19; 13/16"; 1/2"DR. (300mmL)

1/12.4/13.4/0.85' 12.4kg

1/2"DR. Wheel nut 6pt. Flank impact socket w/plug

445120...



NEW

Part no.	Size	<i>l</i> mm	 g	 pc/box
44512017	17	120	264	10
44512019	19	120	306	10
44512021	21	120	348	10

3pc 1/2"DR. Wheel nut impact socket set

4032



Contents: 1/2"DR.
44585 17C...21C 3-Wheel nut 6pt. flank impact socket
17; 19; 21mm (85mmL)

Socket 24/22.3/23.3/1.1' 930g

3pc 1/2" DR. 6pt. Flank impact thin-wall deep socket set

4032TH



Contents: 1/2"DR.
44585 17TH...21TH 3-6pt. Flank impact thin-wall deep socket
17, 19, 21 mm

Socket 24/18.5/19.5/1.1' 770g



1/2" DR. Wheel nut 6pt. Flank impact socket w/plug

4037

NEW



Contents: 1/2" DR.
3-Wheel nut 6pt. flank impact socket
17; 19; 21mm (120mmL)

Socket Δ 940g

4pc 1/2" DR. Hydraulic dual torque impact socket set

4045



- Designed for fastening the lug nut quickly and securely.
- It includes 1/2" DR. 17, 19, 21 and 22mm for ultra thin type.
- Torque range: 115Nm±6% (85ft/lbs±6%)
- Set up the working air pressure at 90 Psi. (6.2 bar; 6.3kg/cm²; 62pa), and ensure the power deliver of the impact wrench between 190~210 Nm. (140~155ft/lbs)

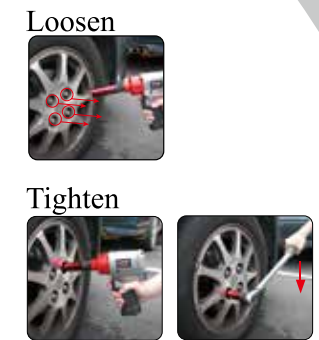

Socket Δ 12/19.0/20.0/0.75' Δ 1583g

4pc 1/2" DR. Wheel nut 6pt. flank impact socket set

4046



Content: 1/2" DR.
44585 17C...22C 4-Wheel nut 6pt. flank impact socket
17, 19, 21, 22mm

Socket Δ 12/13.8/14.8/0.75' Δ 1150g

3pc 1/2" DR. Wheel nut impact deep socket set

4033



Contents: 1/2" DR.
445150 17C...21C 3-Wheel nut 6pt. flank impact socket
17; 19; 21mm (150mmL)

Socket Δ 20/25/26/1.3' Δ 1250g

3pc 1/2" DR. Hydraulic dual torque impact socket set

4035



- Designed for fastening the lug nut quickly and securely.
- It includes 1/2" DR. 17, 19 and 21mm for ultra thin type.
- Torque range: 115Nm±6% (85ft/lbs±6%)
Set up the working air pressure at 90 Psi. (6.2 bar; 6.3kg/cm²; 62pa), and ensure the power deliver of the impact wrench between 190~210 Nm. (140~155ft/lbs)

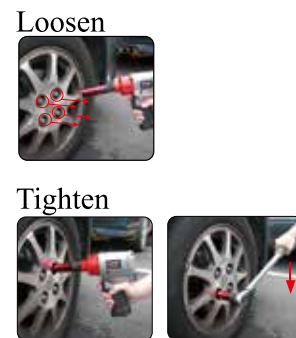

Socket Δ 24/30/31/1.1' Δ 1250g

4pc 1/2" DR. Wheel nut 6pt. flank impact socket set

4046A



Content: 1/2" DR.
44585 15C...21C 4-Wheel nut 6pt. flank impact socket
15, 17, 19, 21mm

Socket Δ 12/13.7/14.7/0.75' Δ 1141g

4pc 1/2" DR. Wheel nut 6pt. flank impact socket set

4046B



Content: 1/2" DR.
44585 17C...23C 4-Wheel nut 6pt. flank impact socket
17, 19, 21, 23mm

Socket Δ 12/16/17/0.87' Δ 1333g

11pc 3/4"DR. Truck wheel impact socket set

6113



- Content: 3/4" DR.**
- 46190 17...21 2- Square impact deep socket 17; 21mm
 - 46190 13.16 1- Square impact deep socket 13/16"
 - 465100 33...41 4- 6pt. Flank impact deep socket 33; 35; 38; 41 mm
 - 465100 1.1.16...1.1.2 4- 6pt. Flank impact deep socket 1-1/16; 1-1/8; 1-1/4"; 1-1/2"

3/27.5/28.5/1.5' 9150g

7PC 1/2" DR. Wheel lug nut removal socket set

907U5



- For removal of wheel locking nuts.
- May also be used on fixings too damaged or corroded for standard sockets.
- Suitable for use with impact wrenches.
- Size: 1/2" DR X 38mm(L) X 17mm, 18.5mm, 20mm, 21.5mm, 23mm, 24.5mm, 26mm



20/18.0/19.0/1.6' 900g

Wheel nut socket for Mercedes-Benz

9T0206



- 17mm wheel nut socket with convex for Mercedes Benz
- Application: Mercedes Benz 221(S Class) and later CL Class and Maybach



Reverse action wheel stud thread restorer kit

906T5



- Unique design allows the two halves of the thread restorer to be fitted on the good thread and wound back over the damaged thread, normally at the end of the stud.
- Traditional thread restorers rely on luck for the restored and undamaged threads to align.
- Three sizes of product a set of capacity: M12 X 1.25 ; M12 X 1.5 ; M14 X 1.5



50/13/14/1.2' 260g

Wheel balancing weight tool

6821



- Easily removes and replaces wheel weights, as well as cutting and crimping.
- Made of heat-strengthened steel. Included comfortable vinyl handle grips.
- With self-open function spring on the handle for easier operation.

30/12.6/13.6/1.3' 245mm 420g

Wheel balancing weight tool

9T0302



- Use to install, remove, trim and tighten clip on wheel weights.
- Includes plastic hammer head for protection of specially coated wheel weights.



48/24.0/25.0/2.7' 500g

Tyre lever

750



Part no.	packing	length	g
750200	100/14.6/15.6/0.56'	200	162
750300	120/31.6/32.6/0.6'	300	370
750380	60/22.9/23.9/0.5'	380	556
750380B	60/22.9/23.9/1.2'	380	382
750500	30/22.0/23.0/0.69'	500	732
750525B	30/24.0/25.0/0.69'	525	800
750650	20/23.2/24.2/0.54'	650	1160
750650B	20/21.8/22.8/0.7'	650	1160



Snap in tire valve installer

9B0301 / 9B0302



Steel constructed tool with deep threaded head for positive sealing of all snap-in type passenger car tire valve stems.



Part no.	packing	g
9B0301	48/16.8/17.8/0.87'	350
9B0302	48/17.1/18.1/3'	356

TPMS Service pack tool set

911T1

NEW



- Used to install/change TPMS sensor and tire valve.
- Content: 1ps 1/4" DR. Torque driver 1~5Nm.
1ps 1/4" DR. Torque wrench 3~15Nm.
1ps Extension 2" (50mm).
2ps 1/4" DR. Deep socket 11mm, 12mm.
3ps 1/4" DR. Star socket bit T10, T15, T20.
1ps Grommet/spacer ring tool.
2ps Valve core torque tool Red 0.25Nm.
Black 0.45Nm.

6/8.5/9.5/1.4' 1410g

3 Function tire pressure gauge

9T0401



Advantages:

- Measure the tire pressure precisely, tolerance 3%.
- Release unnecessary pressure.
- Inflate the tire quickly.
- Specification: 1/4"PT / Max pressure: 14kgf/cm² (200 PSI) / Nozzle length: 30cm



12/7.0/8.0/1.8' 680g

3 Function digital tire pressure gauge

9T0401D

NEW



- 2-1/2" Digital pressure gauge
- Air line inflator with deflator-highly accurate.
- Easy to read. Gauge completed with heavy rubber bumper, includes a 2 feet hose with clip-on chuck.
- Power supply: Lithium battery operated with auto off function
- Operating temperature: 0~50°C
- Accuracy: +/- (F.S.x1%)+0.5 PSI at 2-100PSI
+/- (F.S.x2%)+0.5 PSI at 101-150PSI
- Pressure range: 2-150 PSI

620g

Dual check

9T0402 / 9T0403

9T0402



9T0403



Part no.	length	packing	g
9T0402	5"	100/7.0/8.0/1.1'	75
9T0403	12"	100/17.0/18.0/2.5'	140

2pc Tire valve torque driver set

902U3

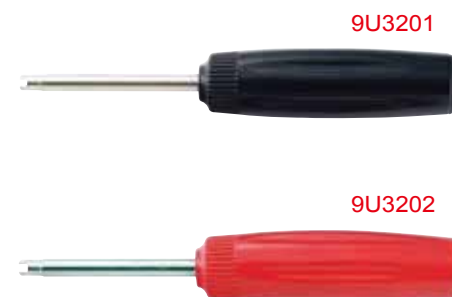

- Tools have internal torque limiting mechanism to prevent over-torquing of tire pressure monitoring system valve cores.
- A must for the tire pressure monitoring system valves to maintain proper tire pressure.
- Each tool is set for a specific maximum torque: Red-25 Ncm (2.2 IN. LB)
Black-45 Ncm (4 IN. LB)



100/12.0/13.0/1.8' 120g

4pc T-handle disclosed tire repair tool set

904T4

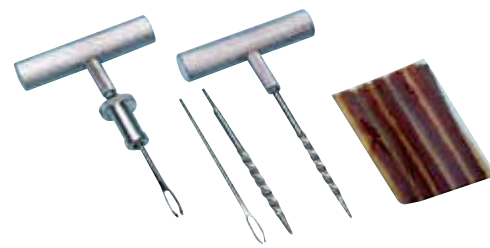

For steel belted radial tire. T-handle disclosed tire repair tool is for inserting plugging material typically in the form of rubber coated strands, into a tire puncture. The plugging material is threaded into the open eye of a needle forming a part of the tool and inserted into the puncture. The inserting motion is limited by a stop free to rotate on the needle's shank so that the ends of the strand are not drawn into the puncture and the stop also limits the withdrawal of the needle.



72/25.5/26.5/2.7' 354g

Roller stitcher

9T0407

- Wood handle for light and portable.
- Bearing inside for easier using.



60/7.4/8.4/0.9' 123g

2pc Wheel stud alignment guide tool set

902B1

- Assists when mounting wheels, especially late models with long lug bolts.
- Applicable: all Mercedes models with lug bolts.
- Size: 12mm x 1.5



200/9.0/10.0/2.7' 45g

2pc Wheel stud alignment guide tool set

902B2

- Assists when mounting wheels, especially late models with long lug bolts.
- Applicable : all Mercedes models with lug bolts.
- Size: M14X 1.5



72/8.4/9.4/1.5' 116g

8pc Wheel stud alignment guide tool set

908B3

- Assists when mounting wheels, especially late models with long lug bolts.
- Applicable: all Mercedes models with lug bolts.
- Size: 12mm X 1.5
12mm X 1.25
12mm X 1.75
14mm X 1.5

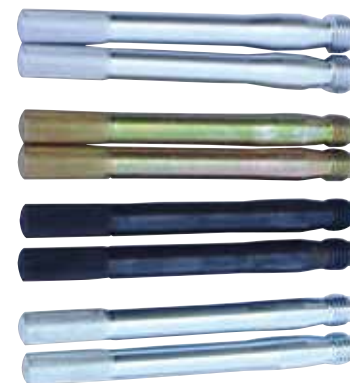

24/19.0/20.0/0.8' 790g

BENZ Bush remover / installer

9T0307

- Removal and replacement tool for metallic bushes on rear axles Mercedes type 201/124/202/140/129/210.
- The Tool incorporates an axial bearing and also incorporates a pressure piece which guarantees the correct position of the new metallic bushes when replaced.



10/19.5/20.5/1.5' 11.7kg

BENZ Axles wheel bearing extractor / installer

9T0311



- A great tool used to replace front wheel bearings without removing the steering knuckle & strut assembly.
- As the spindle assembly isn't removed, there is no need to align front end after the job is done. It saves a lot of time.
- Application: Mercedes Benz, BMW, TOYOTA, VW, MARCH, FORD, VOLVO.



2/18.4/19.4/0.6' Δ 9200g

BMW swing arm sleeve

903T5



- No need to take off the swing arm
- Easy operation saves time
- Aluminum adapter prevents sleeve damage
- Aluminum circumference adapter can be switched when needed.



2/8/9/0.9' Δ 3420g

Sub frame bush remover (Ford Mondeo)

905T5



A specially designed tool for removing and installing the bushes on the rear sub frame on Ford Mondeo.

Contents

A Bridge / B Double headed nut / C Cup / D Bolt / E Dome Washer



20/21.1/22.1/1.4' Δ 1050g

Rear suspension tool for GM VECTRA

908T6



Removing and replacing those stubborn upper and lower rear trailing arm bushes on GM VECTRA'S.



10/17.7/18.2/1.2' Δ 1770g

Rear axle bush installation/removal tool set for Vauxhall / Opel Vectra

908T7



- Suitable for use in situ without removing the rear axle assembly from the vehicle.
- Intended for rapid removal/installation of Vauxhall / Opel Vectra (95-02) upper and lower rear trailing arm bushes.



12/14.7/15.7/1.1' Δ 1225g

5pc VW, AUDI Rear suspension tool

905T4



- Special design for replacing the rear axle mounting bushes, while sit in the vehicle and without the need for removing the rear axle assembly.
- Its fine thread and thrust bearing allow the bush to be fitted quickly and easily without causing damage.
- Applicable: Audi A3/ VW Golf IV/ Bora 1.4/ 1.6/ 1.8/ 2.0 and 1.9d (2001~2003)



36/21.0/22.0/1.8' Δ 580g

Bush remover / installer for VW

907T6



- Suitable for VW Polo (9N) front-axle bracket wishbone silent blocs.
- The removal and replacement of the silent bloc placed in dir bracket is easily and safely carried out directly on the vehicle by using the extractor.
- Applicable: VW - Polo (9N)
SEAT - Ibiza IV, Cordoba (ab Bj. 02) Altea
Skoda - Fabia, Roomster
AUDI - A2.



6/18.0/19.0/1.5' 3000g

21pc Compact wheel hub/bearing kit , Ø 62mm, Ø 66mm, Ø 72mm

921T1

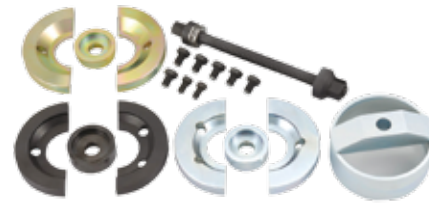

- Professional fitting direct on the vehicle (removal with existing wheel hub extractor or universal sliding hammer).
- Minimum working effort and maximum time saving.
- Simple and safe handling.
- **Only for installation.**
- Can also be optionally used with a workshop press.
- Possible extensions for bearing unit Ø 62+66+72 mm due to the modular system
- Application: Audi A2 , Audi A2 1.2L , VW LUPO , VW Polo FOX , Seat Ibiza , Skoda Fabia



1/12.6/13.8/1.0' 12600g

Wheel hub and wheel bearing extraction & installation set for VW-T5

917T3



- For removing and installing the wheel hub or wheel bearings of built-in parts on cars.
- Suitable for cars with Ø 85mm wheel bearings.
- The design can prevent damage to the new wheel bearing because it provides safe and accurate centering and alignment when changing wheel bearings.
- Application: VW - T5 (front axle) and Touareg with 16-inch chassis

Removing



Insertion



2/16.3/16.8/1.0' 8150g

Wheel hub and wheel bearing extraction & installation set for Ford / Volvo / Mazda

913T2



- For removing and installing the wheel hub or wheel bearings of built-in parts on cars.
- Suitable for cars with Ø 78mm wheel bearings.
- The design can prevent damage to the new wheel bearing because it provides safe and accurate centering and alignment when changing wheel bearings.



- Application: Ford - Focus 2(2004-), CMAX(2003-07, 2007-)
Volvo - C 3 0 (2 0 0 6 -) . C 7 0 2
Cabriolet(2006-) . S40(2004-).
V50(2004-)
Mazda - M3 1.4, 1.6, 1.6D TURBO(2003-)

2/17.5/18.5/1.2' 8750g

Professional wheel bearing tool set for BENZ

927T1



- This tool can make safe, quick and professional replacement and removal of wheel bearing.



- Adaptor ring: Centring Rings - 42 , 45 , 49 , 50 , 54 , 60 , 80mm
Pressure Rings - 66 , 70 , 73 , 75 , 79 , 83 , 84 , 85 , 87 , 88 , 90 , 93mm
- Application: 190 series (W201) , A-Class (W168; W169) , B-Class (W245; W124) C-Class (W202; W203) , E-Class (W210) , M-Class (W163; W164) S-Class (W140) , V-Class (W639)

1/14.6/15.6/1.3' 14480g

Professional wheel bearing tool set For Peugeot / Citroen / Renault

920T2



- This tool can make safe, quick and professional replacement and removal of wheel bearing.



- Adaptor ring: Centring Rings - 35, 37, 42, 45, 60, 75 mm
Pressure Rings - 65, 72, 82, 83 mm
- Application: Peugeot, Citroen, Renault

1/12.0/13.0/1.3' 11400g

■ Universal bush remove and install sleeve

933T1



- Universal application of step discs for bearing bush, silent bearing, hydraulic bearing, and rubber bearing on many kinds of different vehicles.
- 20pcs sleeves: ID ϕ 34~ ϕ 72mm(in 2mm increment)
- 2pcs step discs: use with sleeves.
- 4pcs bolts: M10, M12, M14, M16;
- Length:450mm



1/18.0/19.0/1.1' 18270g

■ Front wheel driver puller

920T1



- A great tool used to replace front wheel bearing without removing the steering knuckle & strut assembly.
- As the spindle assembly isn't removed, there is no need to align front end after the job is done.
- 3pc M12 x P1.5 screws
- 3pc M14 x P1.5 screws

Remove

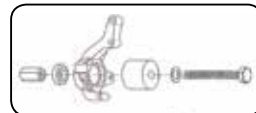

Install

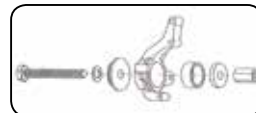

2/16.7/17.7/1.1' 8350g

■ 4WD Front wheel bearing tool

924T1



- 21pc Bearing cup size: 38, 50, 55, 59, 63.5, 66.5, 70.5, 71.5, 73, 73.5, 74.5, 76, 77.5, 81.5, 83.5, 86, 86, 88.5, 91, 102, 102mm
- 1pc Nut
- 1pc Screw
- 1pc Washer



2/21.5/22.3/1.5' 10.5kg

■ Hydraulic steering system pull tool set

949T1



- This set could disassemble damaged bushing and replace new one except the bushing without the hole.
- There is no effect when the control arm is on the car.
- Hydraulic cylinder max. load : 18.2t
- 4 spindle size: ϕ 10mm; ϕ 12 mm; ϕ 14 mm; ϕ 16 mm

Remove



Install



1/20.6/21.6/2.9' 20.6kg

■ Manual steering system pull tool set

950T1



- This set could disassemble damaged bushing and replace new one except the bushing without the hole.
- 4 spindles are especially designed for small bushes and they are available when the control arm is still on the car.
- Hydraulic cylinder: 10 t
- Four pull spindles: M10X1.5P ; M12X1.75P; M14X2.0P; M16X2.0P

Remove



Remove



Install



Install



1/30.6/31.6/2.9' 30.6kg

■ 10pc Bearing race and seal driver set

66603



Makes it easier to insert wheel bearing race and seals without damage to race and axle housing. The set includes 9 disc sizes to fit most standard wheel bearing. Turn discs over to drive seals.

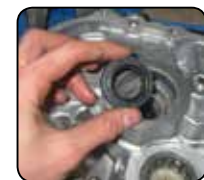

10/17.8/18.7/2.3' 1780g

14pc Master bushing driver, seal, and bearing installer set

915U2



- Set includes four drive handles and 11 adapters (most adapters have 3 or 4 size each)
- Works in any industry, automotive.
- Makes it easier to insert wheel bearing race and bushing seals without damage.

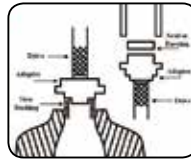

2/16.0/17.0/ 0.78' Δ 8kg

17pc Metric bushing driver set

917T1



- Adaptors held on drivers with knurled nut.
- Fit all remaining bushing.
- Size: 10mm-42mm.

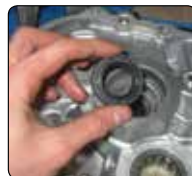

24/17.7/18.7/2' Δ 737g

Universal adjustable bearing race and seal driver

9U0301

NEW



- Aluminum all-in-one self-contained precision driver with rotating handle and expanding jaws to seat races / bearings or seals with ease.
- Variable Jaws cover a range of 18.5 - 89 mm or 0.72 - 3.50 inches.



20/16.6/17.6/1.7' Δ 832g

8pc Adjustable wheel bearing lock nut wrench

908T1

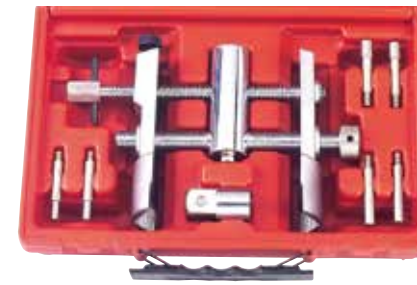

- Adjustable jaws with locking feature to suit both hexagon & octagon wheel bearing lock nuts.
- Includes three sets of pins to suit lock nuts with pin holes.
- Capacity:
6pt lock nuts: 1.3/4" to 5.1/4"(49-135mm) across the flats
8pt lock nuts: 1.3/4" to 5.5/8"(49-143mm) across the flats
Pin diameters: 1/4"(6mm), 5/16"(8mm), 3/8"(10mm).



6/14.8/15.8/1' Δ 2466g

17pc Slide hammer puller set

664



- Designed for removing hub, dent...etc.
- With most popular joints and 3-jaw puller to fulfill most vehicles.
- Content: T-bar, hammer, axle puller, adaptor, 2-jaw head, 3-jaw head, hook and accessories.

2/14/15/1.1' Δ 7kg

Slide hammer puller set

664A



Slide hammer puller set has several pulling attachments to give the user various methods for pulling, maintenance and repair applications; the slide hammer exerts force when needed.



2/19/20/1.9' Δ 9.5g

2pc Axle puller

66401

- Central hole to screw hole 130mm
- Drop forged



2/2/2.5/0.2'

1170g

3pc Axle puller

66402

- Central hole to screw hole 130mm
- Drop forged



2/8/8.5/0.6'

4150g

2pc Axle puller

66403

- Central hole to screw hole 110mm
- Drop forged



2/2.5/3/0.12'

1260g

3pc Axle puller

66404

- Central hole to screw hole 110mm
- Drop forged



2/8/9/0.43'

4375g

6pc Air hammer drift set

906T6

NEW

- 7" (177mm) long parallel shaft design won't get stuck in deep holes.
- Offers the extra driving force of an air hammer where needed.
- Air hammer drift set takes care of rusted shock and strut bolts.
- Sizes Included: 3/16" (5.2mm), 1/4" (6.5mm), 9/32" (6.9mm), 5/16" (7.7mm), 3/8" (9.3mm), 1/2" (12.7mm)

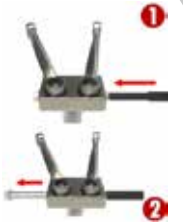

13pc Special Vibro Chisel Set

912T5

NEW

•Contents :

- 1pc 63mm Large Concave Hammer.
- 1pc 1/2"D Adaptor Hammer.
- 1pc 25mm Hammer.
- 1pc Track Rod Hammer.
- 2pc 7" X 20mm, 7" X 24mm Impact ball joint separator.
- 1pc 20mm Flat Chisel.
- 1pc Point Chisel
- 1pc Air Hammer.
- 4pc Drift punch 1/4" (6.5mm), 5/16" (7.7mm), 3/8" (9.3mm), 1/2" (12.7mm)



**BRAKE/
TRANSMISSION**

Ball joint separator

62801

- Heat treated drop forged steel body & bolt for long rough usage.
- Spread ball joints easily where space prevents use of direct action method.
- Jaws open: 19mm



20/24.4/25.4/1.3'

1220g

Ball joint separator

62802

- For splitting track-rod ends, anti-roll bar mountings, ball joints, etc.
- Jaw open: 20mm



20/21/22/1'

1050g

Ball joint separator

62803



- For splitting track-rod ends, anti-roll bar mountings, ball joints, etc.
- Jaw open: 20mm



20/21.2/22.2/0.97' 1060g

Ball joint separator

62804



- Special design 2-stage operating suits most cars and light trucks ball joints in steering & suspension.
- Offset lever permits maximum jaw opening in 30mm & 56mm.
- Jaw open: 22mm



20/24.3/25.3/0.97' 1218g

Ball joint separator

62805



- This universal tie rod end remover will work on most cars and light trucks.
- The necessary force needed to remove tie rod end is easily applied through the center pivot action.
- Fork opening: 20mm
- Reach: 20mm-50mm
- Suitable for: VW-AUDI, BMW, FIAT, FORD, MERCEDES, NISSAN, OPEL, PEUGEOT, RENAULT, ROVER, SAAB, TOYOTA, VOLVO.



20/26.2/27.2/1.1' 1310g

Ball Joint extractor

62806



- For splitting track-rod ends, anti-roll bar mountings, wheel-hub ball joints, etc.
- Jaw open: 22mm
- 2-Stage, 50-80mm.

12/18.2/18.7/0.96' 1620g

Universal ball joint extractor

6281518 / 6281522

6281532 / 6281545

- For splitting track-rod ends, anti-roll bar mountings, ball joints, etc.



Part no.	size	packing	g
	mm		
6281518	18	20/13.9/14.9/0.46'	695
6281522	22	15/10.7/11.7/0.6'	715
6281532	32	10/23.6/24.6/1.4'	2360
6281545	45	10/25.5/26.5/1.4'	2550

Hydraulic HGV ball joint separator

903T2



- For separating HGV ball-joint. Strengthened fork and lever allows for greater force to be applied.
- Remove ball joints easily where space prevents use of direct action method.
- Jaw opening capacity 70 mm; Jaw width 36 mm
- Patented Hydraulic ram provides max. 12 tons.
- SCM 440 material

2/14.0/15.0/1' 7kg

Quick-change ball joint remover

905T8



- Innovative quick change and simple action for suitable fork.
- Enable operator to select correct jaw size without taking entire extractor to the vehicle.
- Adjustable opening angle.
- Jaw opening: 20, 22, 24, 27, 30 mm.
- Thrust Screw Length: 100 mm.
- Pivot Rod Length: 125 mm.



3/18.0/19.0/1.0' 6000g

Ball joint extractor

6280723 / 6280728



- For splitting track-rod ends, anti-roll bar mountings, ball joints, etc., especially in small space conditions.
- **6280723** is for Audi VW, BMW, Ford, Mercedes (W170, W202, ETC), Opel / Vauxhall, etc.
- **6280728** is for Audi A4, A6, A8, VW Passat and Mercedes W203 etc.



art no.	Jaws open mm	Jaws deep mm	packing	g
6280723	23	25	30/24.8/25.8/0.99'	826
6280728	28	25	30/24.1/25.1/0.99'	800

Universal ball joint puller

6280817 / 6280820



Special steel for removing the ball pivots on steering arms, steering tie rocks, steering knuckles etc.

Part no.	packing	jawopen	g
6280817	20/20.4/21.4/1.5'	17mm	1020
6280820	20/23.4/24.4/2.1'	20mm	1170

Universal ball joint separator

62809



- Special steel for removing the ball pivots on steering arms, steering tie rocks, steering knuckles, etc.
- Jaws open: 30mm

10/ 9.0/10.0/0.49' 2900g

Four-way ball joint remover tool

62819



- Heat treated drop forged steel body & bolt for long rough usage.
 - Spread ball joints easily where space prevents use of direct action method.
- Total length: 165mm
Opening angle: 24mm ~ 45mm
Jaw opening: 22mm
Body material: SCM440

10/16/17/0.5' 1600g

Front end service set

906T3

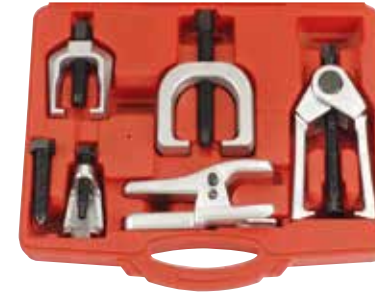

- This versatile set allows for easy removal of the most popular types of pitman arms, tie rods and ball joints.
- Press type ball joint separator allows for ball joint removal without damage to boots and other parts that fork type removers may cause.

3/15.6/16.6/1.25' 5.2kg

Tie rod end & pitman arm puller for compact cars

62811



- For the safe easy removal of pitman arm assembly from compact automobiles.
- Forged, heat-treated yoke with extra heavy center screw
- Opening: 1-1/16"(27mm)
- Pull: 1-3/4"(45mm)

20/8.9/9.9/0.46' 445g



Tie rod end & pitman arm puller

62812



- Redesigned heavy duty tool to be used to remove pitman arms from late model cars and light trucks
- Yoke is forged from high grade alloy steel and heat-treated.
- Opening: 1-5/16"(33mm)
- Pull: 2-1/2"(64mm)

24/19.1/20.1/0.79' 795g



Pitman arm puller

62813



- Designed to handle the toughest Pitman arm pulling jobs on passenger cars and light trucks.
- Features special forged jaws shaped to fit the job.
- To use, simply remove the retaining nut, place the puller jaws behind the pitman arm and tighten the forcing screw.
- Mechanical power does the rest.
- Opening: 1-5/16" (33mm)
- Pull: 2-1/2" (64mm)

20/22.7/23.7/1.1' 1134g



Outer tie rod remover

62814



- Two adjustable jaws special designed for removing outer tie rods of most models.
- Works on imports and domestics; front or rear wheel drives and castors stamped steel steering knuckles.
- Spread: 2-1/2" (64mm)
- Reach: 2-1/4" (57mm)



15/16.4/17.4/0.59' 1090g

Twin-arm bearing pullers

666B



- With clamping bridge and pushing adaptor especially for extracting the inner bearing ring at VW-AUDI cars.
- Size: 90mm X 100 mm



10/11.4/12.4/1.3' 1140g

Ball joint extractor

628E



For splitting track-rod ends, anti-roll bar mountings, ball joints etc.

Part no.	Open size	packing	g
628E18	18mm	60/19.0/20.0/1.2'	316
628E23	23mm	30/16.0/17.0/0.99'	533
628E29	29mm	20/17.6/18.6/0.9'	880
628E40	40mm	12/18.6/19.6/0.97'	1550
628E46	46mm	12/21.0/22.0/1.1'	1750



Universal tie rod end tool

62817



- Heat treated drop forged steel body & thrust bolt.
- Fits most cars, simply insert tool between spindle arm and tie rod, turn thrust bolt with 3/4" (19mm) socket or spanner to spread tie rod easily.
- Fork 18mm (11/16").



30/13.5/14.5/0.4' 450g

Ball joint puller bell vibro-impact

62818 / 6281830
6281832 / 6281839



Part no.	Size mm	packing	g
62818	25	15/19.4/20.4/0.6'	1290
6281830	30	15/19.5/20.5/0.8'	1950
6281832	32	8/22.6/23.6/0.8'	2820
6281839	39	8/27.2/28.2/1.2'	3400



5pc Tie rod ball joint separator set

905T2



Made from heat treated drop forged steel.

Contents:

- 1pc Tie rod separator Opening: 17mm (11/16")
- 1pc Ball joint separator Opening: 24mm (15/16")
- 1pc Pitman arm wedge Opening: 28mm (1-1/8")
- 1pc Handle with lock nut 8" (200mm)
- 1pc Pneumatic handle 7" (180mm)



10/20.0/21.0/1.46' 2kg

Ball joint separator

628



- Tempered drop forged steel one piece construction for long & rough usage.
- Replacing worn out ball joints easily with a hammer striking.
- **628300** also can separate shock absorber links.
- **628400** also can remove CV drive shafts on FWD vehicles
- Material: SCM440.



Part no.	Open size	<i>l</i> mm	packing	g
628300	15/16"	300	25/17.0/18.0/0.38'	680
628400	21/32"	400	20/19.0/20.0/0.38'	950

Ball joint spanner wrench

9T1404



- Designed for removal and installation of ball joint adjusting sleeves on 1/2-, 3/4- and 1-ton Dana open yoke front axles found on Ford, GM, Chrysler, IHC, and Jeep 4WD vehicles.
- Tool permits easy torquing with 1" socket for proper upper ball joint preload.



96/14.0/15.0/1.2' 170g

5pc 1/2"DR. Drive tooth socket for Mercedes

905T7



- Tooth socket for Mercedes Benz axle drive flange.

ID	Length	Tooth width	Usage
905T7-A	70 mm	8 mm	Mercedes Gearbox.
905T7-B	70 mm	6 mm	Mercedes Differential flange.
905T7-C	70 mm	6 mm	Mercedes G-class(W460/W461/W463) Front Axle-wheel bearing.
905T7-D	70 mm	6 mm	Mercedes W114,W115,W116 Models with constant velocity joint axles.
905T7-E	80 mm	8 mm	Mercedes W116,W123,W126 Rear Axle drive flange.

10/17.0/18.0/1.5' 1700g

6pc Ball joint anchor pin press set

906T4



- Special designed for the removal and installation of press fit parts, such as ball joints, universal joints and truck break anchor pins, without having to resort to makeshift methods.
- It contains heavy-duty C frame press, receiver tubes, and installation and removing adapters.

3/19.5/20.5/0.7' 6.5kg



9pc Ball joint anchor pin press set

909T2



- Special designed for the removal and installation of press fit parts, such as ball joints, universal joints and truck break anchor pins, without having to resort to makeshift methods.
- It contains heavy-duty C frame press, receiver tubes, and installation and removing adapters.

2/14.5/15.5/0.7' 7250g

Ball-joint installer/ remover for BENZ (W220/W211/W230)

905T10



- Special design for removing and installing the ball joint on car without removing any parts.
- Applicable: Mercedes Benz W220,W211,W230



3/16.5/17.0/1.1' 5500g

Multi-steering knuckle spreader tool kit

912T3



- Spreads the steering knuckle.
- This enables the removal and refitting of the shock absorbers without the risk of damaging to the aluminum or cast iron knuckle.
- Fully adjustable and is suitable for steering knuckles with either a centralized or eccentric slot.
- Wide range of vehicle applications.



12/13.0/14.0/1.0' 1083g

Audi ball joint tool

62821

NEW



- Required for releasing the lower ball joint to free corrosion etc.
- Effectively a converter to allow the ball joint to be turned after releasing the pinch bolt.
- 1/2" Dr. x H27mm x L36mm with 18mm diameter hole.
- Application: Audi A4 2007~ / A5 2009~ / A6 2011~ / A7 2010~ / Q5 2010~



1/2" DR. BENZ (W163/W164) Pin wrench socket

62820



- Used for Secure the retaining ring during R&R of ball joints.
- Applicable: MERCEDES-BENZ M-CLASS (W163/W164) lower ball joint of front & rear axles.



48/14.0/15.0/0.3' 291g

Lower ball joint socket for Peugeot/Citroen

9T1482

NEW



- Allows fast and simple removal & installation of screw type lower ball joints.
- Suitable for Citroen and Peugeot 405 lower ball joints.



72/16.8/17.5/1.2' 233g

5pc Tie rod adjusting tools

905T1

Unique design permits 360° rotation of the adjusting sleeve. 1/2"sq. drive allows use of ratchet or breaker bar.

Specification:

- Tie rod adjusting tool for compact cars with 3/4" dia. adjusting sleeves.
- Tie rod adjusting tool for compact cars with 7/8" dia. adjusting sleeves.
- Tie rod adjusting tool for compact cars with 1-1/8" dia. adjusting sleeves.
- Tie rod adjusting tool for compact cars with 1-7/16" dia. adjusting sleeves.
- Tie rod adjusting tool for compact cars with 1-13/16" dia. adjusting sleeves.



12/16.0/17.0/1.4' 1330g

Combination wheel alignment wrench

9T0701

- This special double-ended extended length wrench was developed to be utilized when adjusting the front tie rods on most ASIAN, EUROPEAN AND DOMESTIC automobiles which includes over 29 different automobile manufacturers.
- Size: 21mm X 22mm



12pc Inner tie rod tool

912T2

- These tools are specially designed for the inner tie rods that are inaccessible to adjust.
- The long socket can be easily used with eleven open-jaw drivers, size 1-3/16", 1-1/4", 1-5/16", 1-7/16", 14mm, 17mm, 19mm, 22mm, 26mm, 27mm & 33.6mm to most application.
- The inner tie rod can be easily removed and installed by slipping the long socket over tie rod end and connecting it to the open-jaw driver.



6/16.0/17.0/0.6' 2666g

Track rod end remover and installer

9T0204 / 9T0204B

- Designed for remove and install axial joint



Part no.	Application mm	l mm	packing	kg
9T0204	Ø35~ Ø45	400	10/22.5/23.5/2.2'	2.25
9T0204B	Ø28~ Ø35	400	10/21.5/22.5/1.6'	2.15

Multi-purpose inner tie rod tool

9T0801

- The master tie rod tools easily replaces inner tie rod ends without removing the rack & pinion.
- Capacity: 33-42mm



32/12.3/13.3/0.5' 384g

4pc Steering wheel holder & pedal depressor kit

904B2



Steering wheel:

- Firmly holds steering wheel in position when setting toe angle.
- Has a trigger-controlled mechanism and a thumb lock release.



Pedal depressor (brake gas):

- This brake and gas depressor is designed to use in the front seat of the car to obtain lever age.
- Place the point end of depressor on the pedal and use the small release lever above the spring to free the trigger mechanism in order to place the jack in place against the seat.
- Then press the trigger mechanism to put pressure on the brake or gas pedal the pedal jack will maintain the pressure until the release lever is pressed.



6/13.5/14.5/3.1' 2250g

Coil spring compressor

62701



- Use tool to remove and install automotive coil springs up to 5-5/8" OD. designed to grasp a maximum 3/4" wire diameter spring.
- Compress can be used on straight or curved coil spring.
- Forged alloy steel.



12/17.0/18.0/1.3' 1416g

Coil spring compressor

627



- Coil spring compressor made by forging and easy to use.
- Sold and packed in pair.



Part no.	packing	<i>l</i> mm	 g
627270	10/18.3/19.3/1'	270	1830
627370	10/21.7/22.7/1.5'	370	2170

Universal spring compressor

627200 / 627320



627200

- Allows the compressing of the spring at the car, so the strut can be taken out without dismounting the bearing housing.
- This is important at the front axle of VW cars and at rear axle of Ford Mondeo etc.



627320

- For use with all Macpherson.
- The spindles are equipped with contra-rotating threads which eliminate the risk of slipping round the spring.

Part no.	Compression length mm	packing	 g
627200	65-200	10/24.1/25.1/0.86'	2410
627320	65-320	5/14.4/15.4/0.7'	2880

Universal spring compressor

627170



- For replacement of self leveling shock absorbers.
- Particularly for rear axles on Mercedes and Fords.
- Compression length: 85-170mm
- Hex drive situated in the centre of the spindle permitting easy use in confined spaces where other spring compressors can not be used.

10/23.5/24.5/0.7' 2350g

Heavy duty coil spring compressor

627280



- Hooks engage spring which can be compressed by turning hex nut.
- Jaws capacity: 23mm ~ 280mm
- Length 280mm



6/19.5/21.5/0.5' 3.2kg

■ Heavy duty coil spring compressor with jaws & holder

627280U



- No need extra systematic jaw installation / removal
- High security coil spring compressor with 1200kg maximum capacity per pair and adjustable safety bar for additional security
- Jaws capacity : 23 mm ~ 280 mm
- Length 280mm



4/17.0/18.0/0.4' 4.2kg

■ Spring compressor for Mercedes

905T3



- Types 116/123/124/126/129/140/201/202 and 4-matic includes.
- Advantage: Newly developed automatic 3-point safety interlock and automatic freewheel at end of stroke.



5/28.5/29.5/2.46' 5.7kg

■ Professional coil spring compressor

908T5



- Safety yokes carefully shaped to prevent coil spring from bowing.
- Wide availability of spare yokes.
- Main axle length: 453mm
- Small jaw use range: 80-115mm
- Medium jaw use range: 110-150mm
- Large jaw use range: 140-195mm

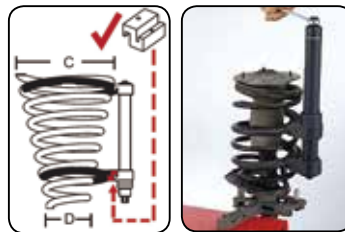

1/13.8/14.8/1.25' 13.8kg

■ Professional coil spring compressor (with cover)

908T8



- Application : BMW, TOYOTA, FORD, MITSUBISHI, VW, AUDI, SAAB, NISSAN, HONDA, SUBARU, VOLVO, OPEL, PORSCHE.
- Main axle length: 453mm
- Small jaw use range: 80-115mm
- Medium jaw use range: 110-150mm
- Large jaw use range: 140-195mm
- Max. Load: 10200 N
- Additional yellow plastic covers could protect the surface of shock absorber

1/13.7/14.6/1.25' 13.7kg

■ Spring compressor stand

9T3403



- Compress the coil spring quickly and easily.
- The opening of attachment shoes can be adjusted according to the diameter of the spring.
- Designed for strong, safe and reliable use.

1/26.4/28.3/3' 26.4kg

■ Strut nut socket for VW/AUDI

9T1481



- Used for removing and installing the top shock retaining nut on most FWD; VW; AUDI.
- Fits into slot in the top of the strut retaining nut
- 22mm (7/8") hex for use with a wrench.



200/15.9/16.9/1.2' 80g

Drive nut set

904T1



Contents:

- No.1: 10.5mm VW GOLF rear axle
- No.2: 12.5mm VW POLO front axle
- No.3: 14.5mm POLO, GOLF, PASSAT, AUDI 80
- No.4: 14.5mm AUSTIN MAERTRO

72/16.3/17.3/1.6' 226g



BENZ (W203) Strut nut socket

9T1401



- Use for removing and installing the top shock retaining nut.
- Applications: BENZ W203.

300/17.6/18.6/0.4' 60g



BENZ (W220) Strut nut socket

9T1402



- Use for removing and installing the top shock retaining nut.
- Applications: BENZ W220.

100/21.6/22.6/0.4' 216g



BENZ W220 Shock absorber service tool set

9T0304



- This tool is for changing the top seal in air suspension.
- Fix suspension strut to a vise. Set 3 legs onto stub bolts in strut. Drive the control forcing screw to compress the seal cup and replace the seal.
- Application: Benz W220

5/8.7/9.7/0.6' 1740g



39pc Turnbuckle for shock absorber's top lid

939T1

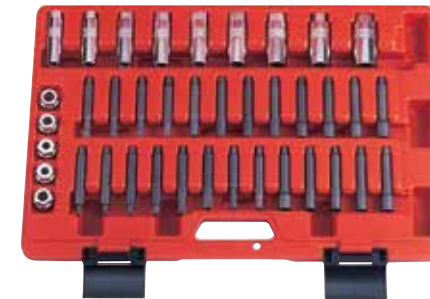

- The complete sizes for using of most kinds of cars.

Contents:

- 5pc external sockets 10.5, 12.5, 14, 14.5, 14.5mm
- 9pc external sockets 1022-14, 16, 1022-17, 18, 19, 1022-21, 22, 24, 27mm
- 9pc central sockets 4, 5.2, 6, 6.3, 7, 1022-39, 9, 10, 12mm
- 2pc central sockets 5, 10mm
- 4pc central sockets 8, 1022-59, 10, 11mm
- 4pc central sockets 5, 6, 7, 8mm
- 3pc central sockets 3, 3.5, 4mm
- 1pc central socket M12
- 2pc central sockets T50, T60

- Apply to : VW, AUDI, M-BENZ, AUSTIN MAESTRO, HONDA, NISSAN, SEAT, FIAT, FORD, ROVER, OPEL, PEUGEOT, RENAULT, CITROEN, TOYOTA, CHRYSLER, BMW, VOLVO.

4/25.0/26.0/2.75' 6.25kg



9pc 1/2"DR. Drive shaft socket

40912



- 1/2"Dr. 14,17,19 mm Hex
 - H14:VW Passat 1996-2001, Audi A4; front and rear axle bolts (AWD).
 - H17:1998-2005 VW Passat, 1999-2004 Audi A6, 2002-2005 Audi A4; front and rear axle bolts (AWD).
 - H19:VW T4,T5,Skoda Fabia.
- 1/2"Dr. 12pt 27,30,32,34,35,36 mm
 - 27mm:Ford Powerstroke;Volvo 480
 - 30mm:For BMW E36, E46; Citroen Saxo;Ford Galaxy; Mercedes W123, W124,W126, W129, W201, W203, W211; Opel Astra F, Astra G; Renault Scenic, Clio, Kangoo; Toyota Avensis, Picnic; VW Golf III, Golf IV, Lupo, Touareg, T5 etc.
 - 32mm:For Fiat Punto; Ford Escort, Mondeo; Mercedes W140; Nissan Almera; Opel Astra H, Vivaro;Subaru Outback etc.
 - 34mm:GM Motors.
 - 35mm:MADZA.
 - 36mm:For Audi; BMW E36, E39, X5; Ford Transit; Seat Lbiza, Cordoba; Nissan Primera; VW Polo, Golf V,Touareg etc.

6/22.6/23.6/1.54' 3767g



■ Axle spindle rethreading set

909T5



- 9pcs Tread restoring die set used to clean or repair axle thread on spindles of M24X2.0 ; M24X1.5 ; M22X1.5 ; M22X1.0 ; M20X1.5 ; M20X1.25 ; 13/16X20 ; 3/4X20.
- Use with 32 mm socket or wrench.

10/16/17/1.2' 1430g

■ 4 pc C.V. boot service kit

904T8

NEW



- Contents :
- 1pc CV Boot clamp pliers
- 1pc CV Joint boot clamp pliers
- 1pc C.V. joint banding tool (with cutter)
- 1pc Drive shaft circlip squeezing pliers

10/16/17/1.2' 1430g

■ CV Boot clamp pliers

62519



A sturdy tool, works on earless-type clamps including those found on GM inboard CV joint.



72/24.7/25.7/2.6' 320g

■ CV Joint boot clamp pliers

62520



For ear type clamps, fits late model GM CV joint boots, also installs PERMA-QUICK type clamps quickly and easily use for filter, cooling system and vacuum lines.



48/18.2/19.2/1.5' 380g

■ CV Dust boot clamp installer with cutter

62521



- Use 1/2" socket wrench to wind and crimp by hand tool is easily disengaged from the band after the band is tightened.
- Cut off easily with built in cutting arm without any other tool.



36/18.3/19.3/1.8' 510g

■ C.V. joint banding tool (with cutter)

62525



- Tool is easily removed by sliding sideways after winding has been completed.



72/20.5/21.5/2.5' 285g

■ Bent type C.V. boot hose clamp cutter

9T0501

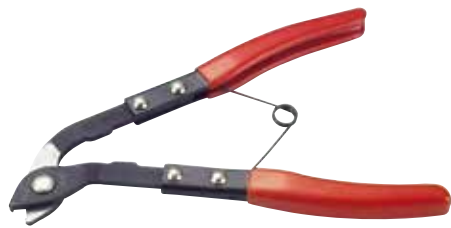

- Designed to cut the stainless steel clamp easily.
- Avoid to harm C.V. boot
- With hardest material SKS III
- Use capacity for hose clamp:
Width: Under 10mm
Thickness: 0.5mm-0.7mm



📦 48/16.8/17.8/2' ⚖️ 350g

■ CV boot clamp pliers

62526



- For all ear-type clamps.
- Application: for AUDI, BMW, CHRYSLER, FORD, GM, HONDA, MAZDA, MERCEDES, NISSAN, OPEL/VAUXHALL, VW etc.
- Designed: to use with extension.
- Handle or torque wrench.



📦 36/20.5/21.5/2.1' ⚖️ 570g

■ Heavy duty CV boot band pliers (with torque drive)

62527



- For assembly of new stainless steel clamp-bands on drive-shafts where a torque setting is required.
- The 3/8" torque wrench is ideal to provide the drive.
- Application: VW, Audi, Seat, Skoda, Opel / Vauxhall, Ford, etc.



📦 20/12.9/13.9/1.8' ⚖️ 645g

■ CV boot installer set (cone, boot installer)

903T1



- Squeeze the arm of the installer and place the large end of the boot over. Press in the small end of the boot. Spray the surface of cone & boot with lubricant.
- Place the cone on the ground and center the boot over the cone.
- Holding the boot to the installer use a firm and fluent motion to press the boot to the base of the cone.
- Place the installer & cone over the joint. Drive the boot over the joint by striking the base of the installer and greasing the joint. And don't stretch over the joint until a tight fit is formed.



📦 12/16.5/17.5/3.5' ⚖️ 1375g

■ Air powered CV boot installation tool

9T0502



- Innovative tool saves time, money and frustration.
- Installs flexible steering and CVJ boots without removing axle from the vehicle or the CV joint from the axle.
- No effort-wasting and no mess.
- Save labour time by up to 70% and prevent damage to CV joint.
- Composite body with simple control valve works from standard workshop air supply.
- Suitable for cars, small vans, light commercial vehicles.
- Material: Aluminum steel
- Capacity: Ø20-110mm



📦 4/12.0/13.0/1.3' ⚖️ 3565g

■ Drive shaft circlip squeezing pliers

62531

NEW



- To pre-tension the drive shaft circlip during assembly of the outer constant velocity joint.
- By holding the drive shaft circlip with special circlip pliers, the outer drive shaft splines can be easily assembled onto the CV Joint.
- Suitable for: VW, Audi, Ford, Honda, Mazda, Mitsubishi, Nissan, Opel/Vauxhall, Seat, Skoda, Subaru, Suzuki, Toyota, etc.



📦 48/17/18.5/1.6' ⚖️ 350g

CV joint assembly removal tool

9T0505

NEW



- Quickly removes the CV joint from the drive shaft without damaging the joint, and keeps hands free for releasing retaining circlip.
- Connector diameter: 29 X 37 mm
- Maximum axle diameter: 37 mm
- Maximum CV joint diameter: 115 mm

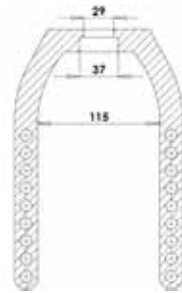

10/21.8/22.8/1.2' 2180g

Fender extending tool

9T0503



- Use for fender collision repair or fender flaring or to increase fender clearance.
- Fit most cars and light trucks with 4 or 5 lugs.
- Roller works on fender from inside wheel well.



2/17/18/2' 8.5kg

Transmission axle holder wrench

9T0201



- This tool use for 2005 & LATER LAND ROVER with V-8 engines.



16/16.8/17.8/1.6' 1050g

Waste oil drain

9T3621



- Capacity: 80L.
- Special designed for no switch beneath of the hopper, and that is not spray any oil absolutely.
- There is a filling net in the hopper that can be removed any dirty wastage on it.
- Use ordinary shop air to move out the waste oil.

1/30/33/7.6' 30kg

Vacuum oil extracting & draining machine

9T3622



- Capacity: 80L.
- Perform dual functions – oil extracting and draining
- Uses compressed air to create a powerful vacuum to extract any kinds of oil, gasoline, diesel, water. (There are some limitations to extract the liquid.)
- Tube size: A:ø6 x L750 ; B:ø7 x L750 ; C:ø6 x L920 ; E:ø3/8" x L650 ; F: Braking oil tube.



1/36/38/7.6' 36kg

Vacuum oil extracting machine & brake bleeder

9T3623



- Capacity: 12L.
- Uses compressed air to create a powerful vacuum to extract any kinds of oil, gasoline, diesel, water, and other anytime.
- With limp cup to check the flow anytime.
- Tube size: A:ø6 x L750 ; B:ø7 x L750 ; C:ø6 x L920 ; E:ø3/8" x L650 ; F: Braking oil tube.



1/13/14/1.9' 13kg

■ Pneumatic oil filling machine

9T3624



- Capacity:25L.
- Enlarged 45 mm oil filler hole for easier to refill oil.
- With oil dispensing gun to easily control the oil filling rate.
- With a dehumidify valve to filter the water from the air compressor.
- Compressed air could be stored in the tank and use for filling oil at any place.
- A clock or digital meter can be attached to measure the volume of the refilled oil. (optional part)

1/18/19/2.9' 18kg

■ Glass covered fluid extractor

9T3625



- To suck liquid by vacuum.
- Append many suction tubes and applicable to oil, transmission oil, brake oil...etc.
- 12L the design of visible glass storing oil box ,it can see storing oil.
- Dual oil reservoir tank design increases the storing capacity(80L+12L).
- Capacity of the tank below:80L.
- Tube size:A:ø6 x L750 ; B:ø7 x L750 ; C:ø6 x L920 ; E:ø3/8" x L650 ; F: Braking oil tube.



1/37/40/9' 37kg

■ Air lubricator for grease

9T3609



- Uses air as power to suck grease into lubrication points.
- Suitable for 00#~2# grease.
- Capacity: 20L.
- Max. pressure that pump could with stand: 7~9 kgs
- Shrink rate: 1/45~1/50
- Volume output: 2L/min
- Hose: 1/4" x 2W x 3M
- Grease output pressure: 180 ~ 405kgs/cm
- Deliver rate: 30cc/sec.

1/21.0/23.0/4.2' 21kg

■ Hand lubricator for grease

9T3610



- With reservoir capacity 25L
- It is suitable for general lubricant and gear oil.
- 4c.c. / each cycle
- Hose: 1/4" x 1W x 2M

1/7.0/9.0/2.2' 7kg

■ Hand lubricator for oil

9T3611



- With reservoir capacity 25L
- It is suitable for general lubricant and gear oil.
- 70c.c. / each cycle
- Hose: 1/2" x 2M PVC yarn pipe

1/7.0/9.0/2.2' 7kg

■ 9 Liters manual / pneumatic fluid extractor

9T3606



- A large 9.0 Liter (2.35gallon) capacity of manual & pneumatic fluid extractor, can be used to extract many kinds of non-explosive liquids.
- Completely automatic using normal shop air, or using hand pump without shop air.
- New safety design, when the tank is full of liquid, air inlet mechanism will be shut off automatically.
- Working Pressure: 70~170 PSI / 4.9~11.9 BAR
- Air inlet: 1/4"
- Air Consumption: 5 CFM

2/9.5/11.5/4.3' 4.75kg

9 Liters pneumatic fluid extractor

9T3606P



- A large 9.0 Liter (2.35gallon) capacity Pneumatic fluid extractor, can be used to extract many kinds of non-explosive liquids.
- Completely automatic using normal shop air, no electric spark, safety for workshop.
- New safety design, when the tank is full of liquid, air inlet mechanism will be shut off automatically.
- Working Pressure: 70~170 PSI/ 4.9~11.9 BAR
- Air inlet: 1/4"
- Air Consumption: 5 CFM

3/12.0/13.0/4.5' 4kg

9 Liters manual fluid extractor

9T3606M



- A large 9.0 Liter (2.35gallon) capacity Manual fluid extractor, can be used to extract many kinds of non-explosive liquids.
- Completely using hand pump when you stay out of door.
- New safety design, when the tank is full of liquid, the unit will be shut off automatically.

2/9.5/11.0/4.3' 4.75kg

5.5 Liters pneumatic fluid extractor

9T3607



- A versatile, portable, air operated fluid extractor for extracting fluids from crankcases, transmission cases, cooling systems and power steering reservoirs.
- This ideal tool designed to be used with many kinds of non-explosive liquids.
- Completely automatic using normal shop air.
- New safety design, when the tank is full of liquid, air inlet mechanism will be shut off automatically.
- Working Pressure: 70~170 PSI / 4.9~11.9 BAR
- Air inlet: 1/4"
- Tank Capacity: 5.5 L
- Air Consumption: 5 CFM

4/9.5/10.5/3.7' 2.4kg

9-Liter pneumatic oil & liquid dispenser

9T3612

NEW



- New safety design, with the dual-safety protection device, when tank pressure reaches the set level, the devices will start the pressure release automatically.
- Unique design, with the one-touch convert button device, simple and easy function converting between extracting and filling.
- Working pressure: 70~170 PSI/ 4.9~11.9 BAR
- Air inlet: 1/4"
- Tank capacity: 9.0 Liter
- Air consumption: 5 CFM

2/6.6/7.6/3.3' 3460g

Pneumatic brake fluid extractor / refilled kit

9T3608



- The unit creates a powerful vacuum that is used to bleed and flush hydraulic brakes and clutches.
- Large, stable base so it won't tip, requires no special adaptors.
- Automatic refilling of the master cylinder reservoir while bleeding.
- Universal drain valve fits to most standard recycling system.
- Working Pressure 70~170 PSI / 4.9~11.9 BAR
- Air inlet: 1/4"
- Air Consumption: 5.0 CFM
- Extracting Tank Capacity: 2.0 L
- Refilling Bottle: 1.0 L

2/5.0/5.8/2.3' 2.6kg

Oil drain tank

9T3701



- The most capacity is 30L.
- The safety capacity is 20L in any positions without splitting.



1/16.0/17.0/3.1' 16kg

Oil drain tray

9T3706 / 9T3707



- Material: PE
- Dish to save the slop oil.
- Special design on rim for prevent the oil comes out.
- And the producing hole also has special design to pour out the oil.
- Molded handles and 45° spout permit easy handling and pouring.

Part no.	Volume		packing	g
	L			
9T3706	8	10/5.4/6.4/3.2'		540
9T3707	16	10/9.5/11/5'		950

Oil drain tray

9T3708



- Volume: 24L
- material: PE

5/9/11/5.6' 1800g

Oil draion tray

9T3709 / 9T3710



9T3710

9T3709

Part no.	Volume		packing	g
	L			
9T3709	6	10/6.5/8.5/6.3'		665
9T3710	10	10/10/12/9'		1000

Replaceable oil pan separator and clean set

919T1



- Breaks gasket seals on engine sumps, transmissions or any difficult to separate gasket joints.
- The copper blade could avoid damage on gasket or oil pan connection joint surface.
- Clean up wheel tool helps use to clean all small spaces on cylinder head.



50/18.5/19.5/1.42' 360g

Exhaust spring clamp remover / installer

9T0301



- Essential for safe, controlled removal of clamps attaching exhaust to manifold.
- Special design provides "LEVERAGE" required to expand the strong spring clamps.
- For Volkswagen.



48/21.5/22.5/2' 448g

2pc Rubber ring hook tool set

902T1

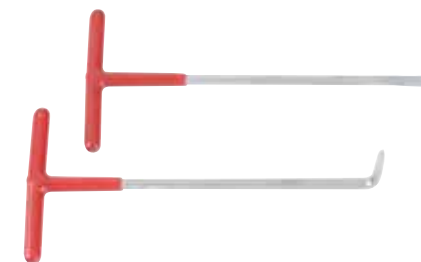

- Essential for safe, controlled removal of clamps attaching exhaust to manifold.
- Special design provides "LEVERAGE" required to expand the strong spring clamps.
- For Volkswagen.



72/18.5/19.5/6' 220g

Exhaust hanger removal tool

9T0316



- Easily remove exhaust rubber hanger for a wide range of applications.



710g

3pc Tailpipe expanders set

903T3



- Heavy-duty tools flare and expand in mufflers and tailpipes. Features exist long hex bar.
- Three sizes fit all automotive applications.
- Capacity:
 - 903T3A:** 1-1/8"-1-3/4" (29-44mm)
 - 903T3B:** 1-1/2"-2-7/16" (38-62mm)
 - 903T3C:** 2-1/8"-3-7/16" (54-87mm)



7/20.0/21.0/0.9' Δ 3kg

Magnetic adjustable camber gauge

688



- It has a simple leveling adjustment of +/-3°. Housed in a durable, non-magnetic casing with a magnetic head that attaches firmly to rotors or spindles.
- Time/money saving device.
- Return a strut to its original camber after repair or replacement.
- Measure camber change before reinstalling alignment heads during camber kit installation.
- Check the amount of camber change before reinstalling tire and wheel assemblies on trucks receiving offset alignment bushings.



12/6.1/7.1/1.3' Δ 510g

Magnetic adjustable camber gauge

68801



- It has a simple leveling adjustment of +/-3°. Housed in a durable, non-magnetic casing with a magnetic head that attaches firmly to rotors or spindles.
- Time/money saving device
- Return a strut to its original camber after repair or replacement.
- Measure camber change before reinstalling alignment heads during camber kit installation.
- Check the amount of camber change before reinstalling tire and wheel assemblies on trucks receiving offset alignment bushings.

30/15.0/16.5/1.8' Δ 500g

Camber adjustment tool for BMW rear axles

902T2

NEW



- Ideally suited for adjusting the camber on the rear axle.
- The rear wishbones can be moved with this therefore setting the camber.
- Without this tool the correct and exact adjustment of the camber is almost impossible.
- Application range: BMW 3 series, (E36, E46).

VW Automatic transmissions socket

9T0205



- Used for loosening and tightening the nut on the drive shaft.
- M6-speed manual gearbox 0A3, 4-wheel drive.
- Application: VW

20/20.0/21.0/0.44' Δ 1000g

Transmission clutch spring compressor

9T0317



- For removing and installing the transmission rear clutch piston snap ring.
- Adjustable, for most models of American cars and light trucks.



12/16.0/17.0/1.8' Δ 800g

VW Audi 7 Speed DSG clutch installer and remover

905T11

NEW



- This tool is designed to install and remove the clutch of gearbox.
- Application : VW Golf 2004 - present,
VW Golf Plus 2005 - present ,
Audi A3 2004 - present with 7-speed gearbox (code 0AM)
VW Touareg 2003 - present with 6-speed gearbox (code 08D)

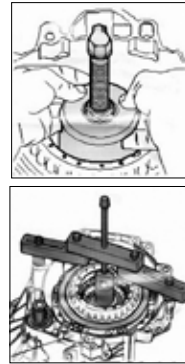

7-Speed DSG mechatronic unit remover for VW, AUDI, SEAT

9G4601

NEW



- Specially designed to remove load from plungers of mechatronic unit when you insert the tool between clutch lever and gear housing.
- Applicable: VW, AUDI, SEAT 7-speed dual clutch gearbox.

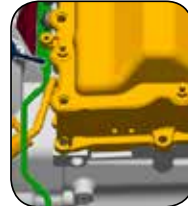

154g

8pc Auto transmission filling system

908T9



- The unit is designed to fill fluid into the transmission, differentials and transfer cases.
- Capacity: 7.5L
- Outlet: 80cc/ cycle
- Viscosity Range: up to SAE 140
- Application: Suits Honda, Nissan, BMW, Audi VW, DSG, Porsche, Mini Cooper, Mercedes Benz, etc.



2/10.0/11.2/3.4'

4700g

1/2" DR. 7 PC Wheel bearing locknut sockets set

907T5



- 1PC 55mm Hex locknut Socket:
For use on front wheel adjusting nuts found on Toyota FJ. Ln, and RN models
- 1PC 2-3/8" Hex locknut Socket:
Works on 1984-92 Ford Rangers & Bronco IIs with automatic locking hubs
- 1PC 2-1/2" Hex locknut Socket:
Found on rear axles and various front axle applications on light-duty trucks.
- 1PC 2-1/2" Rounded Hex locknut Socket:
Works on 1995-96 Ford F/150 trucks and full-sized Broncos with automatic locking hubs.
- 1PC 2-3/4" Rounded Hex locknut Socket:
Works on 3/4" and 1-ton Ford F-250 and F-350 trucks with automatic locking hubs.
- 1PC 2-9/18" Rounded Hex locknut Socket:
Works on 1990, 1993 Dodge trucks with Dana 60 manual hubs.
- 1PC 2-3/8" Rounded Hex locknut Socket:
Works on 1990- recent Ford Rangers, Bronco IIs, and Explorers with automatic locking hubs.

3/16.0/17.0/1.4'

5335g

Toyota Hub nut spanner 54mm (1/2"DR.)

9T1450

NEW



- Wheel bearing lock nuts are easy to remove or install with these specially designed sockets.
- High-grade truck wheel bearing lock nut socket is made of high-strength steel.
- Measure from flat to flat to determine size of lock nut.
- Size: 1/2"DR. 54 mm hex socket

24/13/13.5/1.5'

526g

Service jack 3 Ton

9U3921



- Ideally suited for all automotive, agriculture and light truck repair facilities.
- Pump is operated by both activating foot pedal to provide speed to contact the load, and activating " T " handle to lift it.
- Hydraulic power unit with dust seals to prevent oil contamination.
- Large heavy duty rear swivel caster wheels provide easy maneuvering and positioning of jack.

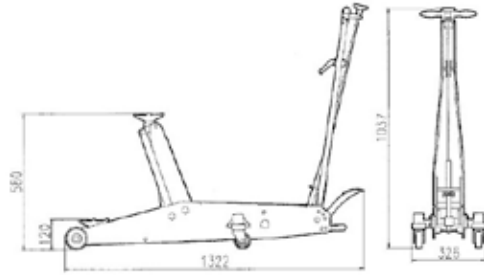

1/67.0/71.0/4.6' 67000g

Jack stands

9U39...



- These models incorporate a lever and ratchet assembly for adjusting the height.
- Same as Model 9U3902 but these models are newly designed with rubber pads which can prevent the auto body from damage.

Part No.	Capacity (ton)	Height range (mm)	Base Size (mm)	Packing	g
9U3901(one pair)	3 ton	270-420	177 x 194	1/6.0/6.6/0.66'	6000
9U3902(one pair)	3 ton	290-440	177 x 194	1/6.6/7.2/0.66'	6600

Jack stands

9U39...



- These models are designed for use with trucks, height adjustment is made using the knurled nut and threaded stud.

Part No.	Capacity (ton)	Height range (mm)	Base Size (mm)	Packing	g
9U3903	12 ton	456-710	ψ467	1/18.5/19.5/0.7'	18500
9U3904	12 ton	614-868	ψ590	1/21.0/22.0/1.0	21000
9U3905	12 ton	710-1065	ψ670	1/25.0/26.0/1.0	25000

4. Truck



IVECO truck tool

Page 4-1 ~ 4-1



SCANIA truck tool

Page 4-9 ~ 4-12



BENZ truck tool

Page 4-1 ~ 4-3



VOLVO truck tool

Page 4-13 ~ 4-16



MAN truck tool

Page 4-3 ~ 4-6



General truck tool

Page 4-17 ~ 4-28



BPW truck tool

Page 4-6 ~ 4-9



IVECO Axle nut socket 110mm

9T1405



- Six sided drive H 36.
- Positive drive of the axle nut.
- Any extensive slipping is avoided.
- Milled out profile.
- Robust execution.
- Can be used with an impact wrench or torque wrench.
- Special steel.
- Application range: Iveco Eurotech Cursor HA, etc.

SW(mm)	H(mm)	Outer ø(mm)	L(mm)
110	36.0	134.0	118.0

8/19.0/20.0/1.37' 2375g

IVECO Axle nut socket 98 mm

9T1406



- Six sided drive H 36.
- Positive drive of the axle nut.
- Any extensive slipping is avoided.
- Milled out profile.
- Robust execution.
- Can be used with an impact wrench or torque wrench.
- Special steel.
- Application range: Iveco Euro Cargo, etc.

SW(mm)	H(mm)	Outer ø(mm)	L(mm)
98.0	36.0	122.0	117.0

8/18.0/19.0/1.37' 2250g

BENZ Axle nut socket 95mm

9T1407



- Six sided drive H 36.
- Positive drive of the axle nut.
- Any extensive slipping is avoided.
- Milled out profile.
- Robust execution.
- Can be used with an impact wrench or torque wrench.
- Special steel.
- Application range: Mercedes Benz axle trailers.

SW(mm)	H(mm)	Outer ø(mm)	L(mm)
95.0	36.0	118.0	157.0

8/21.0/22.0/1.42' 2625g

BENZ Rear axle nut socket 105-125 mm

9T1408



- Rigid locating tube.
- High accuracy of fit.
- Extremely robust execution.
- Suitable for high tightening and loosening torque.
- Special steel.
- Application range: Mercedes Benz Actros rear axle, HL/HL 8 (Hypoid), etc.

Inner ømm	Outer ømm	L mm	Stud ømm	Stud	Stud width mm
105.0	125.0	180.0	116.0	6	10.0

6/17.8/18.8/0.9' 2965g

BENZ & MAN Rear axle nut socket 80-95 mm

9T1426



- Rigid locating tube.
- Optional with expander sleeve(bayonet locking system).
- High accuracy of fit.
- Extremely robust execution.
- Suitable for high tightening and loosening torque.
- Special steel.
- Application range: Mercedes Benz Atego Rear axle on Vitaro 814 and MAN, etc.

Inner ømm	Outer ømm	L mm	Stud ømm	Stud	Locating tube ømm	Stud width mm
80.0	95.0	175.0	87.0	6	49.0	10.0

12/19.6/20.6/1.1' 1630g

Benz & Man Rear axle nut socket 95-115 mm

9T1427



- Optional with sleeve locating tube.
- High accuracy of fit.
- Extremely robust execution.
- Suitable for high tightening and loosening torque.
- Special steel.
- Application range: Mercedes Benz and MAN 10+13t Reduction axle, Hypoid and Trailer axle NR7/4, Omnibus 0305G + 0405G, etc.

Inner ømm	Outer ømm	L mm	Stud ømm	Stud	Stud width mm
95.0	115.0	110.0	101.0	6	11.5

8/23.0/24.0/0.7' 2875g



BENZ & MAN Clamp nut socket 56 mm

9T1424



- For professional loosening and tightening.
- Extremely versatile.
- Rectangular form.
- Usable with rectangular clamp nuts on the axle stub.
- Suitable for exact torque with a 3/4" square drive.
- Milled-out profile.
- For machinery usage.
- Special steel.
- Application range: DAF, MAN trucks / BENZ trucks / BENZ buses / KASSBOHRER / SETRA.

SW mm	DR.	H mm
56.0	3/4"	53.0

20/18.5/19.5/0.36' 925g

BENZ & MAN Clamp nut socket 60 mm

9T1425



- For professional loosening and tightening.
- Extremely versatile.
- Rectangular form.
- Usable with rectangular clamp nuts on the axle stub.
- Suitable for exact torque with a 3/4" square drive.
- Milled-out profile.
- For machinery usage.
- Special steel.
- Application range: BENZ SK , Actros / MAN 9 tons strengthen / DAF / KASSBOHERE / SETRA

SW mm	DR.	H mm
60.0	3/4"	53.0

20/16.3/17.3/0.36' 815g

3/4" DR. BENZ & MAN Pitman arm puller 42mm

6281842



- Pressure pieces in the spindle rotating mounted.
- Save time and labor.
- No need to destroy the pitman arm.
- Cast forged execution.
- Special steel.
- Size: 3/4" DR. 63(A) x 42(B) mm
- Application: Benz Actros & MAN 414

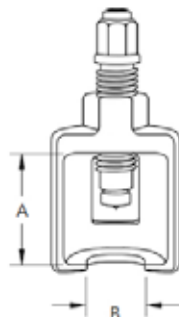

6/22.0/23.0/0.66' 3666g

MAN TGA Drive axle nut socket 133-145mm

9T1410



- Six sided drive H 60.
- Optional with sleeve Locating tube.
- High accuracy of fit.
- Extremely robust execution.
- Suitable for high tightening and loosening torque.
- Special steel.
- Application range: MAN TGA 460drive axle, V9-82L-01(Disk brake/ABS), etc.

Inner ømm	Outer ømm	L mm	Stud ømm	Stud	Stud width mm
133.0	147.0	160.0	118.0	6	12.0

4/18.6/19.6/1.3' 4650g

MAN TGA Front axle nut socket 133-145mm

9T1409



- Six sided drive H 60.
- Optional with sleeve Locating tube.
- High accuracy of fit.
- Extremely robust execution.
- Suitable for high tightening and loosening torque.
- Special steel.
- Application range: MAN TGA Front axle, V9-82L-01(Disk brake/ABS), etc.

Inner ømm	Outer ømm	L mm	Stud ømm	Stud	Stud width mm
133.0	147.0	110.0	118.0	6	12.0

4/15.3/16.3/0.7' 3825g

MAN TGA Front axle nut socket 101-110mm

9T1411



- Six sided drive H 60.
- High accuracy of fit.
- Extremely robust execution.
- Suitable for high tightening and loosening torque.
- Special steel.
- Application range: MAN TGA Front axle, V9-82L-01 (Disk brake/ABS), etc.

Inner ømm	Outer ømm	L mm	Stud ømm	Stud	Stud width mm
101.0	110.0	80.0	93.0	6	7.2

8/21.5/22.5/0.5' 2687g

MAN truck transmission socket 53.5mm

9T1412



- This special socket removes, transmission nut on MAN trucks.

Inner ømm	Outer ømm	L mm	DR.	Stud ømm
53.5	72.0	75.0	3/4"	4

12/16.8/17.8/0.35' 1400g

MAN Front wheel hub extractor tool 115mm

9T1429



- The tool is used to remove the front-wheel hub.
- Use this axle with spanner to spin the screw.
- Extremely robust execution.
- Flat oval form.
- European truck repair tool.
- Special steel.
- Specification:M115*P1.5
- Application:MAN truck

4/16.0/17.0/1.1' 4000g

3/4" DR. MAN Pitman arm puller 67mm

6281867



- The tool is designed for extracting pitman arm of MAN.
- It's different from traditional puller that prevents pitman arm from damage.
- Use H6,70mm socket to remove the fixed nut on the pitman arm before using this tool.
- Cast forged execution.
- Special steel.
- Size:3/4" DR. 75(A) x 67(B) mm
- Application:MAN Tractor Trailer FE410A/FE414.

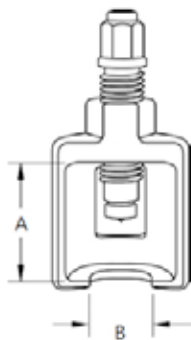

4/18.4/19.4/0.66' 4600g

3/4" DR. MAN Star impact socket for HGV Cylinder head bolt (E18 , E20 , E24)

466110



- Size : E18 , E20, E24
- 3/4" DR. 110mm.
- For HGV cylinder head bolts.

Part no.	Size	mm	g	Applications
46611018	E18	110 mm	520	For MAN commercial vehicles M2000 and MAN buses with D08 engines.
		30/15/16/0.4'		
46611020	E20	110 mm	540	For MAN commercial vehicles F2000 , F90 , F8 and MAN buses with D25 and D28 engines.
		30/16.2/17.2/0.4'		
46611024	E24	110 mm	591	For MAN commercial vehicles with D20 engines.
		30/17.7/18.7/0.4'		

BPW Rear hubcap nut socket 111mm

9T1417



- Special heavy duty oval shape socket with two flats on the side to suit BPW rear axle hub retaining cap nuts found on later model Japanese commercial trucks, tractors and other automotive industrial equipment.
- For extracting the rear axle cover.
- Male Hex Drive: 1-5/8" (41mm)
- Size: 4-3/8" (111mm) Across the flats.
- Application range: BPW 12 tons

Inner ømm	Outer ømm	L mm	H mm
111.0	132.0	94.0	41.0

6/17.0/18.0/0.6' 2833g

BPW Rear hubcap nut socket 95mm

9T1420



- For extracting the rear axle cover.
- Application: BPW 6.5~9 tons truck.

6/15.0/16.0/0.6' 2500g

BPW Rear hubcap nut socket 120mm

9T1416



- Special heavy duty eight point socket to suit BPW rear axle hub retaining cap nuts found on later model Japanese commercial trucks, tractors and other automotive industrial equipment.
- Male hex drive: 1-5/8" (41mm)
- Size: 4-3/4" (120mm) 8 Point opening
- Application range: BPW former 16 tons

Inner mm	Outer ømm	L mm	H mm
120.0	143.0	95.0	41.0

6/18.0/19.0/0.6' 3000g

BPW Rear hubcap nut socket 109mm

9T1418



- Special heavy duty eight point socket to suit BPW rear axle hub retaining cap nuts found on later model Japanese commercial trucks, tractors and other automotive industrial equipment.
- Socket for the rear axle cover.
- Male Hex drive: 1-5/8" (41mm)
- Size: 4-5/16" (109mm) 8 Point opening
- Special steel
- Application range: BPW 12 tons

Inner ømm	Outer ømm	L mm	H mm
109.0	129.0	94.0	41.0

6/15.0/16.0/0.6' 2500g

BPW Axle nut socket 65mm

9T1419



- For the dismantling and assembly of BPW axle nuts
- Extremely versatile
- Flat oval form
- Suitable for exact torque with a 3/4" square drive
- For machinery usage
- Special steel
- Application range: 6.5~9 tons trucks

Inner ømm	Outer ømm	L mm	H mm
65.0	82.0	66.0	36.0

4/15.5/16.5/0.5' 3875g

BPW Axle extractor 135mm

9T1430



- Use this tool on axle with spanner to spin the screw.
- Extremely robust execution.
- Flat oval form.
- European truck repair tool.
- Special steel.
- Specification: M135*P2.0.
- Application: BPW ECO 10~12 tons old model.

2/13.5/14.5/0.6' 6750g

BPW Axle extractor 136mm

9T1431



- Use this tool on axle with spanner to spin the screw.
- Extremely robust execution.
- Flat oval form.
- European truck repair tool.
- Special steel.
- Specification: M136*P2.5.
- Application: BPW ECO Plus 8~12 tons, BPW ECO 10 tons new model..

2/13.5/14.5/0.6' 6750g

BPW Axle extractor 155mm

9T1432



- Use this tool on axle with spanner to spin the screw.
- Extremely robust execution.
- Flat oval form.
- European truck repair tool.
- Special steel.
- Specification: M155*P3.0.
- Application: For former model of 16 tons truck.

2/13.5/14.5/0.6' 6750g

BPW Axle extractor 125mm

9T1433



- Use this tool on axle with spanner to spin the screw.
- Extremely robust execution.
- Flat oval form.
- European truck repair tool.
- Special steel.
- Specification: M125*P2.0.
- Application: For former 12 tons trailer.

4/16.0/17.0/1.1' 4000g

3/4" DR. Wheel capsule and axle nut socket

9T1435



- For clean, easy loosening and tightening of flat oval wheel capsules and axle nuts for BPW axles.
- For the dismantling and assembly of grease capsule on BPW axles.

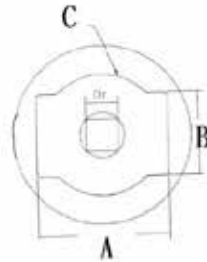

Part no.	A mm	B mm	C mm	DR.	g	packing
9T1435A	65	40	60	3/4"	1000	16/16.0/17.0/0.65'
9T1435B	80	50	72	3/4"	1187	16/19.0/20.0/0.65'
9T1435C	85	50	80	3/4"	1062	16/17.0/18.0/0.65'
9T1435D	95	40	68	3/4"	1583	12/19.0/20.0/1.2'
9T1435E	110	45	107	3/4"	2000	10/20.0/21.0/1.0'
9T1435F	120	48.5	115	3/4"	2500	8/20.0/21.0/1.1'

SCANIA Front wheel nut socket 80mm

9T1422



- This eight sided 80mm socket is specifically for front-wheel nut sockets on SCANIA trucks.
- SCANIA front-wheel nut socket.

Inner ømm	Outer ømm	L mm	H mm
80.0	100.0	102.0	41.0

12/21.6/22.6/0.65' 1800g

SCANIA Front wheel nut socket 100mm

9T1423



- Control the nut with slide rod to adjust bearing.
- This eight sided 100mm socket is designed specifically for rear wheel nut sockets on Scania trucks.

Inner ømm	Outer ømm	L mm	DR.
100.0	123.0	84.0	3/4"

6/17.0/18.0/0.5' 2833g

SCANIA Transmission clutch front main shaft socket

9T1421



- This special socket removes.
- European truck repair tool.

Inner ømm	L mm	Stud ømm	Stud	Stud width mm	DR.
80.8	76.1	72.5	4	6.75	3/4"

10/18.5/19.5/0.8' 1850g

3/4" DR. SCANIA Front - wheel shock absorber spring socket

9T1436



- To apply for SCANIA front-wheel shock absorber spring screws removal / installation.
- European truck repair tool.
- Size: 3/4" DR. 28.5(A) x 37.4(B) mm
- Application: SCANIA

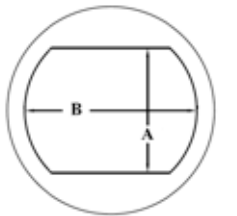

36/16.0/17.0/0.61' 444g

3/4" DR. SCANIA Rear axles damper rod socket

9T1437



- To apply for SCANIA rear axles damper rod screws removal / installation.
- European truck repair tool.
- Size: 3/4" DR. 34.5(A) x 47.5(B) mm
- Application: SCANIA

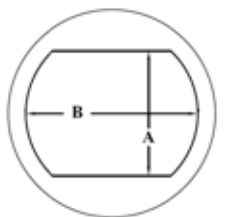

24/15.0/16.0/0.42' 625g

3/4" DR. SCANIA Rear wheel shock absorber spring socket

9T1438



- To apply for SCANIA rear wheel shock absorber spring screws remove / install.
- European truck repair tool.
- Size:3/4" DR. 34.5(A) x 56(B) mm
- Application:SCANIA

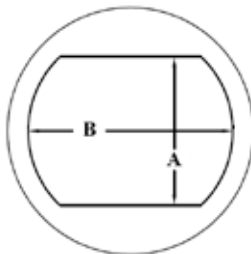

24/15.0/16.0/1.0' \triangle 625g

3/4" DR. SCANIA pitman arm puller 58mm

6281858



- To use on pitman arm of European trucks. No need to destroy the pitman arm.
- Cast forged execution.
- Special steel.
- Size:3/4" DR. 75(A) x 58(B) mm
- Application:European Truck, such as SCANIA.

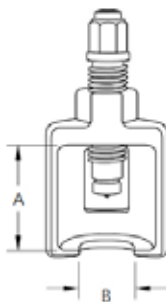

4/18.4/19.4/0.53' \triangle 4600g

3/4" DR. SCANIA Star impact socket (E28)

46611028



- To remove and install the bolt of crankshaft bearing cap.
- Applicable:SCANIA Ti engine.

Part no.	Size	mm
46611028	E28	110 mm

30/17.6/18.6/0.4' \triangle 588g

1/2"DR. SCANIA Truck camshaft rotator tool

9K0101



- This tool is designed to rotate the camshaft for timing on SCANIA truck engines.
- Size:Spline Tooth x 1/2"Drive..

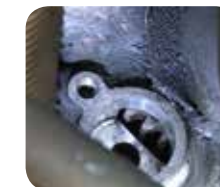

100/22.6/23.6/0.45' \triangle 226g

Caliper adjuster socket 24mm

9T1439



- Size:H24 , 5 teeth , 46mm L.
- Barreled round shape.
- Material:SCM440.
- Application:Most European trucks, such as SCANIA, VOLVO... etc.

100/17.0/18.0/2.0' \triangle 170g

Axle nut socket 140mm

9T1428



- Positive drive of the axle nut.
- Robust execution.
- Can be used with an impact wrench or torque wrench.
- Ideally suited for brake restoration working.
- Forward tension with SW 32mm is at 150 N-m.
- Angle of rotation 20-30 with SW 46.
- Special steel.
- Application range: SAF Euro axle, etc

Inner \varnothing mm	L mm	H mm
140.0	135.0	32,46

4/17.5/18.5/1.36' \triangle 4375g

1/2"DR. VOLVO Camshaft rotator tool

9K0102

- Special 1/2" drive tool for rotating the engine and camshaft for the setting the timing on Volvo diesel truck engines.
- Applicable: Volvo engines D9A, D12, D16C..



20/16.0/17.0/0.9' 744g

VOLVO Flywheel turning tool

9K0103

- NEW** •Special design to rotate the flywheel of crankshaft for correcting the timing position.
- Applications: Volvo/Renault MP8, MP10 engines.



620g

VOLVO / SCANIA Wheel shaft cover socket 115 mm

9T1440

- For Dismantling The Front / rear Wheel Axle Cover Of VOLVO
- Size: 3/4"Dr., 8 Point, 115mm

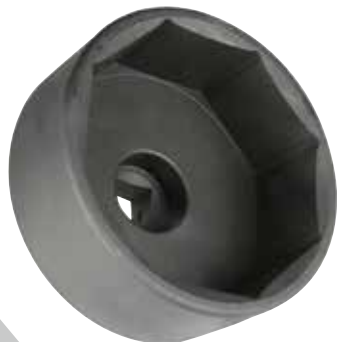

6/18/19/0.6' 3kg

VOLVO Truck axle nut socket 105mm

9T1441

- Fix bearing while removing or installing the truck nut.
- Use the air wrench or rod to control the nut to tighten or loosen bearing.
- Size: 1"Dr. , 6 Point, 105mm



6/18/19/0.6' 3kg

VOLVO Truck axle nut socket 95mm

9T1442

- Fix bearing while removing or installing the truck nut.
- Use the air wrench or rod to control the nut to tighten or loosen bearing.
- Size:1"Dr. , 6 Point, 95mm



6/17.5/18.5/0.6' 2916g

VOLVO King pin upper cover socket 80 mm

9T1443

- To remove king pin upper cover.
- Size:3/4"Dr. , 6 Points, 80mm
- Applicable: VOLVO FM12



10/15/16/1' 1500g

VOLVO Rear wheel shock absorber spring washer removal socket

9T1445



- Use for VOLVO rear wheel shock absorber spring washer removal socket.
- Size:3/4"Dr. , 28.5(A) x 43.5(B) mm, height 60mm
- Applicable: VOLVO rear axle e.g. FH, for removal and installation of leaf spring bolts on the springs.

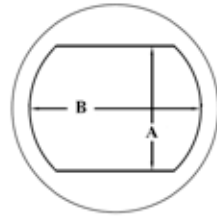

24/19.2/20.2/0.86' 800g

VOLVO Front wheel shock absorber spring washer removal socket

9T1446



- Special two pin socket for removal and replacement of spring washer holding the front wheel shock absorber on Volvo trucks.
- Pin Diameter:8.73 mm
- Circle diameter:37 mm
- Drive Size:27 mm Hexagon
- Applicable:VOLVO e.g. FL6 / F10 / F12

60/10.8/11.8/0.55' 180g

VOLVO Truck shock absorber upper base nut extractor / installer

9T1447



- For extracting and installing the shock absorber upper base nut of VOLVO Truck.
- Size:3/4"Dr. , 53mm Dia x 4 lugs.

30/22/23/1.23' 733g

VOLVO Truck front / rear brake shoe lining inside caliper

9T1448



- Extend wider and hold open brake shoe steel by locking A1169 inside caliper closer. Take out the bolts and change new brake shoe lining.
- Applicable:All kinds of VOLVO trucks.

10/19.5/20.5/1.76' 1950g

VOLVO Truck fan bearing base socket

9T1449



- This special four lug socket is used to remove the fan base bearing on engines fitted to Volvo trucks.
- Applicable:All kinds of VOLVO trucks.

24/19.5/20.5/0.8' 812g

Sleeve locating tube 60-67 mm

9T1413



- Practical connector system with fixing screw.
- Usable for different groove socket nuts(module systems).
- Enables stable work position.
- Prevents slippage of the socket.
- Extremely robust execution.
- Change through loosening of the grub screw on the hexagon.
- Special steel.

Inner ømm	Outer ømm	L mm
60.0	67.0	140.0

20/16.6/17.6/1.03' 830g

Sleeve locating tube 54-60 mm

9T1414



- Practical connector system with fixing screw.
- Usable for different groove socket nuts(module systems).
- Enables stable work position.
- prevents slippage of the socket.
- Extremely robust execution.
- Change through loosening of the grub screw on the hexagon.
- Special steel.

Inner ømm	Outer ømm	L mm
54.0	60.0	140.0

20/13.8/14.8/1.03' 690g

Sleeve locating tube 46-52 mm

9T1415



- Practical connector system with fixing screw.
- Usable for different groove socket nuts(module systems).
- Enables stable work position.
- Prevents slippage of the socket.
- Extremely robust execution.
- Change through loosening of the grub screw on the hexagon.
- Special steel.

Inner ømm	Outer ømm	L mm
46.0	52.0	140.0

20/10.0/11.0/1.03' 500g

9pc Sockets for ball bearing nuts (outer teeth)

909T3



- Outer-teeth sockets for ball bearing nuts.
- 1/2": KM4,5,6,7
- 3/4": KM8,9,10,11,12

Size	⊙	Nut slot	Length
KM4	Ø32	4	55
KM5	Ø38	5	55
KM6	Ø45	5	55
KM7	Ø52	5	55
KM8	Ø58	6	68
KM9	Ø65	6	68
KM10	Ø70	6	68
KM11	Ø75	7	68
KM12	Ø80	7	68

3/17.6/18.6/0.88' 5.8kg



Pickup truck & bus ball Joint extractor 30mm

6281830



- For removing the truck rod end from the drag link.
- The best tool for removal light truck ball joint.
- Size:60(A) x 30(B) mm
- Application:All light trucks. Such as BMW (E39), Benz(W203/W210/W211/W220/W221), Mitsubishi Delica, Canter, Toyota Dyna

15/5/6/0.6' 980g



Medium sized wagon ball Joint extractor 32mm

6281832



- The best tool for removal truck ball joint.
- No damage to ball joint and related parts.
- Size:92(A) x 32(B) mm
- Application:3.5 tons~8.8 tons trucks.

8/22.6/23.6/0.69' 2820g

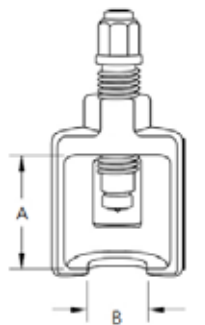

Truck ball Joint extractor 39mm

6281839



- The best tool for removal truck ball joint.
- No damage to ball joint and related parts.
- Size:60(A) x 39(B) mm
- Application:over 4 tons and European trucks , HINO Special for MAN 414 drag link.

8/27.2/28.2/0.69' 3400g

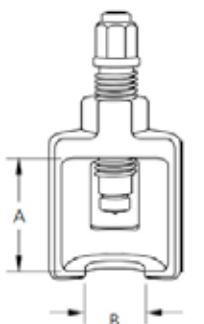

3/4" DR. Ball joint puller 47mm

6281847



- Pressure pieces in the spindle rotating mounted.
- Spindle suitable for impact wrenches.
- Less space required.
- Cast forged execution.
- Special steel.
- Size: 3/4" DR. 63(A) x 47(B) mm
- Application: HINO, ISUZU, UD, FUSO, 8.8 tons~10.5 tons truck.

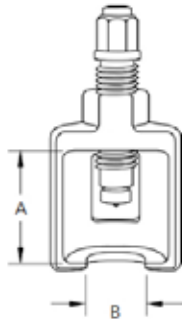

6/22.8/23.8/0.66' 3800g

3/4" DR. Ball joint puller 62mm

6281862



- Pressure pieces in the spindle rotating mounted.
- Spindle suitable for impact wrenches.
- Put is on steering mechanism pitman arm, then take pitman arm apart.
- Cast forged execution.
- Special steel.
- Size: 3/4" DR. 75(A) x 62(B) mm
- Application: 15 tons~35 tons of HINO, ISUZU, NISSAN, FUSO truck and bus.

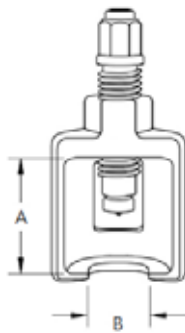

4/18.4/19.4/0.53' 4600g

Reverse action wheel stud thread restorer kit –Truck

905K1



- Unique design allows the two halves of the thread restorer to be fitted on the good thread and wound back over the damaged thread, normally at the end of the stud.
- Traditional thread restorers rely on luck for the restored and undamaged threads to align.
- Three sizes of product a set of capacity: M18 X 1.5, M20 X 1.5, M22 X 1.5, 7/8"-11 BSF1
- Applications:
M18 X 1.5 - DAF, IVECO, MAN, RENAULT, VOLVO I
M20 X 1.5 - MERCEDES, SCANIA I
M22 X 1.5 - DAF, FORD, MAN, RENAULT, VOLVO, MERCEDES, SCANIA I
7/8"-11 - SCANIA

20/16.5/17.5/1.1' 840g

Hydraulic HGV ball joint separator

903T2



- For separating HGV ball-joint. Strengthened fork and lever allows for greater force to be applied.
- Remove ball joints easily where space prevents use of direct action method.
- Jaw opening capacity 70 mm; Jaw width 36 mm.
- Patented Hydraulic ram provides max. 12 tons.
- SCM 440 material.

2/14.0/15.0/1.0' 7000g

11pc 3/4"DR. Truck wheel impact socket set

6113



- Content: 3/4" DR.
- 46190 17...21 2pc- Square impact deep socket 17; 21mm
- 46190 13.16 1pc- Square impact deep socket 13/16"
- 465100 33...41 4pc- 6pt. Flank impact deep socket 33; 35; 38; 41 mm
- 465100 1.1.16...1.1.2 4pc- 6pt. Flank impact deep socket 1-1/16; 1-1/8; 1-1/4"; 1-1/2"

3/27.5/28.5/1.5' 9150g

Double power lug wrench

681600



- Foldable: easy to carry and store.
- Sliding: increase power.
- Deep sockets.
- Socket size: 24/27/32mm & 3/4"SQ.DR.
- Length : 600 mm

6/20.0/20.5/0.84' 3333g

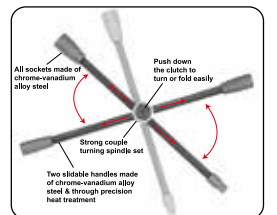

9pcs Center sleeve pin set

909K1



- Designed to protect the wheel threads when taking off the wheel.
- Center sleeves kit with inner thread for exactly mounting on truck wheels.

Each kit includes 3 sleeves.

Applications:

M18 X1.5 - DAF , IVECO , MAN , RENAULT , VOLVO
M20 X1.5 - DAF , FORD , MAN , RENAULT , VOLVO
. MERCEDES , SCANIA

M22 X1.5 - Alloy wheels MAN , MERCEDES



10/17.0/18.0/1.5' 2812g

Dual head truck tire gauge

9T0405

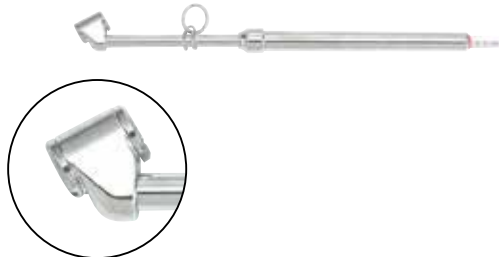

- Measures from 10 to 150 PSI
- Accuracy: +/- 2PSI

100/18.0/20.0/3.0' 180g

Dual head truck tire gauge (Straight-on)

9T0405B



- Measures from 10 to 150 PSI
- Accuracy: +/- 2PSI

100/20.0/22.4/3.1' 200g

8pc Adjustable wheel bearing lock nut wrench

908T1

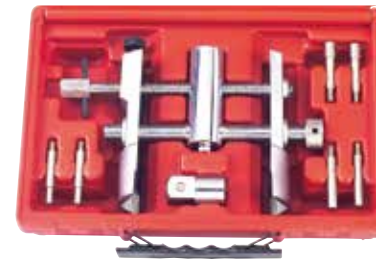

- Adjustable jaws with locking feature to suit both hexagon & octagon wheel bearing lock nuts.
- Includes three sets of pins to suit lock nuts with pin holes.
- Capacity:
6pt lock nuts: 1.3/4" to 5.1/4" (49-135mm) across the flats
8pt lock nuts: 1.3/4" to 5.5/8" (49-143mm) across the flats
Pin diameters: 1/4" (6mm), 5/16" (8mm), 3/8"(10mm).

6/14.8/15.8/1.0' 2466g



Truck jack stands

9U39...



- The jack stands are of heavy-duty design and high strength legs for truck & bus support.
- 9U3911 & 9U3912 are designed with rubber pad which can prevent the truck & bus body from damage.

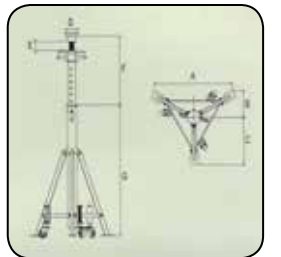

Item No.	Capacity (ton)	A (mm)	B (mm)	C (mm)	D (mm)	E (mm)	F (mm)	G (mm)	W (kgw)	Packing	g
9U3911	6.8	803	235.5	445	127	0	540	870	47	1/43.5/46.0/3.27	43500
9U3912	6.8	803	235.5	445	127	70	670	1426.5	59	1/56.0/59.0/4.67	56000
9U3913	15	948.5	308.5	513	127	70	700	1389	98	2/196.0/211.0/58.3	98000

ISUZU Crankshaft rear oil seal installer

902K1



- This tool is specially designed for preventing the oil seal from damage when installing it .
- Oil seal genuine no: BZ4962-E , 3-97071561.
- Application: ISUZU 3.5tons (4JB1,4JG2) (130HP / 150HP).

8/17.0/18.0/1.1' 2125g

4pc Injector socket set

904K1

- For removal replacement of the pressure nut injector holder.
- Applicable: BENZ truck, MAN, NEOPLAN, SETRA, IVECO, SCANIA, RANAULT...etc.



18/19.0/19.5/1.3' 1055g

HGV Diesel Injector nozzle Socket

9G0125

- The especially-designed toothed socket is for installing and removing the diesel injection nozzle on BENZ, MAN and SCANIA commercial vehicles.
- Specially-designed with window, toothed end and M14 pulling force screw.



40/20/21/0.8' 500g

4pc Diesel injector socket set

904G3

- 1/2" DR. socket for diesel injector removal and installation.
- Applicable: ALFA ROMEO, CHRYSLER, BMW, FORD, VW, MERCEDES, AUDI, OPEL, VAUXHALL, SEAT, VOLVO, ROVER also on VOLVO, MAN 2.5TD & SCANIA HGVS.



Diameter	Description	Length	Proof torque
22 mm	injector socket (6 pt)	110 mm	215 N-m
22 mm	injector socket (12 pt)	75 mm	215 N-m
27 mm	injector socket (12 pt)	78 mm	390 N-m
28 mm	injector socket (12 pt)	78 mm	430 N-m

10/11.4/12.4/0.8' 1140g

Diesel injector puller

9G0114

- Assists removal of stubborn BOSCH and LUCAS Diesel injectors saves time and money when injectors are difficult to remove.
- With M8 /M12 / M14 adaptors
- Applicable: VOLVO, SCANIA.



40/16.018.0/1.8' 400g

Diesel injector seat cutter set

907G7

- This kit has been specially design for cleaning and re-cutting injector seats on modern common rail diesel engines.
- 15mm flat reamer for universal injector.
- 17mm flat reamer for DELPHI / BOSCH injectors (BMW / PSA / RENAULT / FORD)
- 19mm flat reamer for BOSCH injectors (MERCEDES CRD)
- 19mm angled reamer for FIAT / IVECO.
- T handle, Pilot post



20/19.2/19.7/2.0' 950g

Diesel engine nozzle tester & cleaner

905G13

- For all diesel engine cars & trucks.
- For Testing injection nozzle opening pressure, leakage spray pattern, Atomization & Chatter Characteristic & Cleaner.
- Pressure Gauge: 70mm.
- Pump: 11mm.
- Stroke: 20mm.
- Discharge Amount: 2.0 cc.
- Weight: 8 kg.
- Simple & Easy to Operate by Hands.
- Follow New International Standard.
- Clean the Nozzle if used with 3M Cleaning Solution.
- Capacity Gauge : 9000 PSI (640 kg/cm²)
- Adaptors: M-12 x P1.5, M-14 x P1.5, M-16 x P1.5



2/15.7/16.7/1.27' 7850g



9pc Pre-heater plug tools

K909G4



- To ream out and clean the bore between the glow plug and precombustion chamber.
- Size: M12 x 1.25, M10, pre-heater plugs with 10mm across flats.
- Fasten the glow plug with the correct torque.
- 1/4" DR. Universal socket size: 8, 9, 10, 12 mm.

Thread Diameter	Tightening Torque
8 mm	8-15Nm(0.8-1.5Kgm)
9 mm	15-20Nm(1.5-2.0Kgm)
10 mm	15-20Nm(1.5-2.0Kgm)
12 mm	20-25Nm(2.0-2.5Kgm)

6/9.9/10.9/0.78' 1650g

Diesel compression tester

916G2



- 2-1/2" dial, glycerin filled gauge with glass lens in stainless steel housing 4,500 psi rated nylon jacketed pressure hose assembly.
- Dual scale 0-1,000 psi; Metric scale 0-70 bar. 13 piece adapter set (Deere & BMW adapters included).

4/21.6/22.6/2.24' 5400g

Turbo system pressure tester kit for commercial vehicles

907G19

NEW



- For fast diagnostics of the air charging.
- Enables time-saving and appropriate determination of leaky intercoolers and invisible cracks in air charging hose.
- Three pairs of stepped adapters : 105-110, 115-120, 125-130



Valve seal remover and installer kit for truck

902K2



- Two valve keeper removers and installers operate much quicker than standard compressors.
- Valve retention tools hold multiple valves in place at a time.
- Special deep-reach access valve seal pliers.
- All-in-one valve service kit with valve spring keeper removers installers, valve retention tools and valve seal pliers.
- Applicable: Trucks only.

20/14.5/15.5/0.76' 1316g

Piston ring pliers

62302

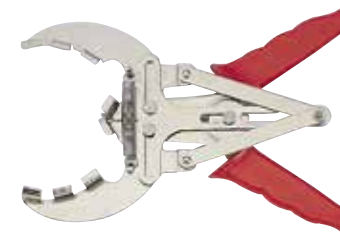

- Removes or installs piston rings easily and fast without risk of breakage or distortion.
- Capacity: 110mm-160mm pistons in diameter.

50/18.5/19.5/3' 420g



Self-gripping oil filter wrench

9B0704



- Removes all oil filters from 95-165 mm.
- Used with 1/2" square drive tools.

10/14.0/15.0/0.81' 1400g



Three-legged oil filter wrench

61913



- 3-leg, 1-way, fit 1/2" square drive
- Capacity 75 ~ 130mm (3" to 5-1/8")

24/24.0/25.0/0.79' 950g

■ Heavy-duty oil filter wrench

61905



- Wide steel bank designed to meet the high torque requirement of truck, bus, RV and heavy duty equipment filters.
- Used with 1/2" square drive tools.

Part no.	Packing	Capacity	g
61905120	36/24.8/25.8/4.5'	4-1/8" to 4-3/4" (105mm - 120mm)	690
61905135	36/25.2/26.2/4.5'	4-1/2" to 5-1/4" (115mm - 135mm)	700
61905145	36/25.6/26.6/4.5'	5" to 5-3/4" (125mm - 145mm)	700

■ Oil filter master pliers

639230



- These multi-purpose locking pliers will lock and grip oil filters or any irregular shaped object for quick positive tightening or removal.
- They can be adjusted and fastened for applications at any angle.
- Capacity: 2.1/8" to 4.1/2" (55mm to 120mm).
- Length: 230 mm.

40/19.5/20.5/1.7' 480g

■ Axle oil drain tray for HGV

9T3711



- For clean and simple removal of the drive shaft
- Suitable for different wheel diameters.
- Volume: 3L
- Material: PE



20/7.8/9.3/5.2' 390g

■ Hand lubricator for gear oil

9T3611



- With reservoir capacity 25L.
- It is suitable for general lubricant and gear oil.
- 70c.c. / each cycle.
- Hose: 1/2" x 2M PVC yarn pipe.

1/8/9.5/2.21' 7000g

■ Hand lubricator for grease

9T3610



- With reservoir capacity 25L
- It is suitable for general lubricant and grease.
- 4c.c. / each cycle
- Hose: 1/4" x 1W x 2M

1/8.5/10/2.2' 7000g

■ Lever type grease gun

88704



- Electric-plated finish for long service life.
- Short stroke "lever action" for easy use.
- Vented head cap for easy filling.
- Used standard 14 oz. Grease cartridge.
- 3-way loading: Standard 14 oz. Cartridge, pressure filler and bulk 400 c.c.

20/23.0/26.9/2.3' 1300g

5. Auto Body



Body dent puller tool
Page 5-1 ~ 5-2



Body pull clamp
Page 5-14 ~ 5-20



Wiper arm removal tool
Page 5-30 ~ 8-31



Body repair tool
Page 5-3 ~ 5-7



Body filler tool
Page 5-20 ~ 5-21



Dent repair tool
Page 5-8 ~ 5-8



**Upholstery fastener /
Clip tool**
Page 5-21 ~ 5-24



Weld / Bending pliers
Page 5-9 ~ 5-14



**Glass maintenance
tool**
Page 5-25 ~ 5-29



6pc Extra large sliding hammer set

906M2



Contents:

- 1- Hammer and shaft
- 1- Plate (9*120mm)
- 1- Plate (9*130mm)
- 1- Plate (9*140mm)
- 1- Plate (9*210mm)
- 1- Plate (9*220mm)

- For different extent of indentation, it has five hooks attached.
- The hooks will completely fit kinds of plate to your problem.
- It is durable and made by steel.

2/18.0/19.0/0.91' 9kg



10pc 12LBS Knocker set

910M1

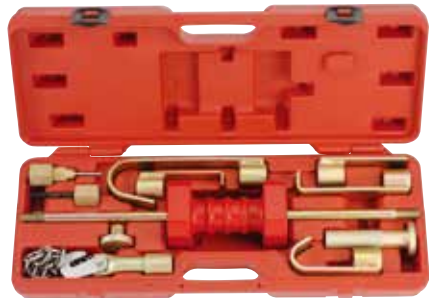

For those hard to reach places on unit-sized body reconstruction, when working on fenders, rocker panels, door edges, bumper ends, aligning doors, hoods, trunks etc. hammers both ways without reversing. Solid 5/8" steel slide shaft, pipe end nose adapter is machined and plated.



2/20.0/21.0/1.3' 10kg

11pc 10LBS Dent puller set

665B



Contents:

- 1pc Pipe (Diameter 22.5mm x 590mmL)
- 1pc Pipe (Diameter 22.5mm x 200mmL)
- 1pc 2 Hole pipe (Diameter 29mm x 40mmL)
- 1pc Hammer (10lbs.)
- 1pc Plate (6mm x 170mm) / 1pc Plate (6mm x 120mm)
- 1pc Plate (6mm x 120mm) / 1pc Plate (6mm x 200mm)
- 1pc Plate (3mm x 100mm)
- 1pc Chain & hook
- 1pc Hex nut (29mm)

2/16.8/17.8/1.1' 8420g

9pc Body pry bars and body wedge tools set

909M1

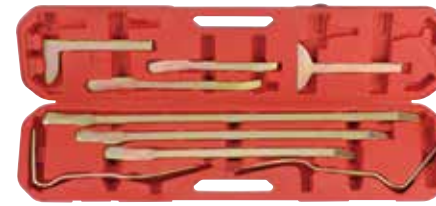

These pry bars are manufactured from special steel and are particularly suitable for:

- Dismantling stubborn components.
- Positioning components.
- Holding components in required position.
- Spreading clamp-fixtures, etc.

2/23.0/24.0/1.52' 11.5kg

13pc Body pry bars and body wedge tools set

913M2



These pry bars are manufactured from special steel and are particularly suitable for:

- Dismantling stubborn components.
- Positioning components.
- Holding components in required position.
- Spreading clamp-fixtures, etc.

2/23.0/24.0/1.52' 11.5kg

4pc Body and fender dent puller set

904M2



Often, the biggest time-consuming part of dent removal is the removal and installation of interior panels and upholstery. This tool eliminates those steps. Simply drill a hole at the base of the dent and thread in the tool's self-tapping screw. A few sharp blows of the slide hammer will pull the dent out.

12/18.6/19.6/1.4' 1550g

Air suction dent puller

905M4



- With 120mm & 150mm pad
- With 3LB(1.36kgs) sliding hammer
- With brass shut off valve
- With 13" length inlet hose
- Air exhaust from the handle
- With 1/4" air plug
- Optional pad: 60mm(905M4-60)



4/17.0/18.0/3.3' 3.8kg

11pc Auto body repair set (interchangeable)

911M1



- Material: Main hammer made from drop forged tool steel; all bits made from Chrome-Vanadium
 - Double locking device holding tight
 - Save space / weight
 - Save money / time
 - Create high efficiency
- Warning:** Form hitter hits shank has to be inserted to the hole's bottom.

10/23.0/24.5/1.8' 2300g

7pc Auto body repair tool set

50713B



- Contents:**
- 62602 1-Pick & finishing hammer
 - 62603 1-Light shrinking hammer
 - 62604 1-Standard bumping hammer
 - 68301 1-Utility dolly
 - 68302 1-Curved dolly
 - 68303 1-Heel dolly
 - 68304 1-Toe dolly

3/22.0/23.0/1.51' 7300g

7pc Auto body repair tool set

50719



- Contents:**
- 62604 1-Standard bumping hammer
 - 62602 1-Pick & finishing hammer
 - 68305 1-Grid toe dolly
 - 68306 1-Double end hand dolly
 - 68302 1-Curved dolly
 - 68353 1-Drip molding spoon
 - 68354 1-Light dinging spoon

3/22.4/23.4/1.5' 7460g

7pc Auto body repair tool set

50720



- Contents:**
- 1-Rubber heel dolly (size: 2-1/2" x 3" x 1-1/2")
 - 1-Large rubber heel dolly (size: 5" x 3" x 1-1/2")
 - 1-Rubber double end hand dolly
 - 1-Rubber general purpose dolly
 - 1-Rubber wedge dolly
 - 1-Rubber toe dolly
 - 1-Rubber drip molding spoon



2/22.0/23.0/1.5' 11kg

Twist & shrinking hammer

62601

Specially designed hammer surface profile has a good performance of expanding and making convex on sheet board.



40/20.3/21.3/2.6' 510g

Pick & finishing hammer

62602

Crowned face, with round point head to remove low spots when metal finishing.
Round face:Φ40mm



382g

Light & shrinking hammer

62603

Flat face+milled square face
Round face:Φ40.5mm
Square face:38mm



438g

Standard bumping hammer

62604

Flat face
Round face:Φ40.5mm
Square face:38mm



440g

Angle and flat double spoon

68351



- Length: 510 mm
- Width: 59mm
- Head material: 1055 medium carbon steel
- Head polished: mirror polished

8/19.4/20.4/1.2' 2425g

Angle and flat short double spoon

68352



- Length: 401 mm
- Width: 58mm
- Head material: 1055 medium carbon steel

8/14.3/15.3/1.2' 1787g

Drip molding spoon

68353



- Length: 236 mm
- Width: 49mm
- Head material: medium carbon steel

12/15.1/16.1/0.53' 1258g

Light dinging spoon

68354

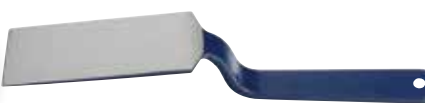

- To ding ridges smooth and level.
- When held against ridge and struck with hammer, spreads blow over large area.
- Making smooth job and preventing damages to metal or finish.
- Length: 250 mm
- Width: 50.8 X 109mm
- Head material: medium carbon steel

50/18.9/19.9/0.52' 378g

Short single spoon (light duty type)

68355



- Length: 286mm
- Width: 51mm
- Head material: 1055 medium carbon steel

20/17.0/18.0/0.45' 850g

Utility dolly

68301



Provides convenient hand holding during heaviest blows and seal different crowned working face.

- Length: 61mm
- Width: 70mm
- Depth: 69mm

1240g

Curved dolly

68302



- Length: 132mm
- Width: 70mm
- Depth: 69mm

1132g

Heel dolly

68303



Designed to reach easily into sharp corners and wide radii.

- Length: 79mm
- Width: 60mm
- Depth: 30mm

870g

■ Toe dolly

68304



The large flat face is frequently used in shrinking and dinging flat panels.

Length: 120mm
Width: 58mm
Depth: 29mm

⚖️ 1308g

■ Grid toe dolly

68305



- To use for shrinking metal stretched by dents.
- Length: 122mm
- Width: 59mm
- Depth: 29mm
- Head material: 1055 medium carbon steel

📦 20/27.7/28.7/0.46' ⚖️ 1385g

■ Double end hand dolly

68306



- Length: 66mm
- Width: 61mm
- Depth: 74mm
- Head material: 1055 medium carbon steel

📦 20/23.5/24.5/0.5' ⚖️ 1175g

■ Corrosion assessment tool

9M1501



- Combines tapping hammer, blunt scraper and short lever.
- For checking bodywork and structural corrosion.
- Designed for the vehicle inspectorate.

📦 100 / 11.0 / 12.0 / 2' ⚖️ 110g

■ Body gap gauge tool

9M0107

NEW

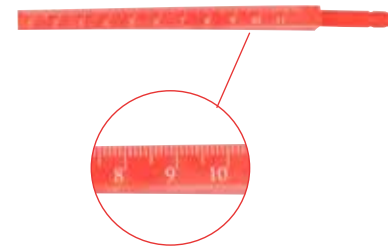

- A simple and perfect tool for correcting body / interior alignment (the gaps on hoods, deck lids, doors...).
- Very useful tool, especially for bearing work and for gauging slots.



📦 144/4/5/1.4' ⚖️ 30g

■ Paintless dent repair line board

902M5

NEW



- Great visual aid for PDR (Paintless Dent Repair), it allows you to locate your tool tip as well as to see the distortion of dent on the panel.
- 240mm x 200mm board with suction cup, can be positioned at any angle.
- White board with black lines for medium to dark coloured vehicles.



📦 24/10.3/11.3/3.5' ⚖️ 400g

■ Blending hammer and tap down tool set

905M7

NEW



- Aluminum blending hammer with 300mm (12") shaft.
- Aluminum tap down tool (adjustable in length): 70mm(2-3/4") ~ 100mm(3-15/16")
- 4 changeable tips with 5/16" threads.
- Tips conveniently store in the comfortable handle.



■ Dent repair Kit

915M1

NEW



- Ideal for repairing the vehicle body small damage or minor dents.
- Content: 1ps Dent puller set.
1ps Glue gun 100V-240V 60W with 2 glue sticks..
1ps Plastic razor blade.
10ps Glue pads.



📦 3/6.37/7.37/0.88' ⚖️ 1472g

7pc Locking pliers & clamp set

50721



Content:

- 614 125...250 2-Locking pliers 5"; 10"
- 614A175 1-Locking pliers (straight jaw) 7"
- 615150 1-Long nose locking pliers 6"
- 66011 1-Locking "C" clamp 11" with easy release
- 66101 1-Sheet metal tool
- 66201 1-Welding clamp

3/14.0/15.0/1.5' 4650g

Locking "C" clamp with easy release

660



- Cr-mo drop forged jaws
- Bodily heat-treated
- Welding brazed
- Nickel plated



Part no.	size	packing	g
66006	6"	72/17.6/18.6/0.76'	245
66011	11"	30/22.5/23.5/1.2'	750
66018	18"	20/22.8/23.8/1.1'	1140
66024	24"	20/23/24/1.5'	1150

Locking "C" clamp with pad

660...D



Part no.	Size	Packing	g
66006D	6"	72/17.5/18.5/0.67'	245
66011D	11"	36/23.2/24.2/1.2'	772
66018D	18"	20/23.5/24.5/1.1'	1175
66024D	24"	16/23.1/24.1/1.6'	1438

Sheet metal tool

66101



- Size: 8"
- Cr-mo jaws
- Bodily heat-treated
- Welding brazed
- Nickel plated
- Function: U-shaped jaws allow access and perfect visibility when welding.



48/24.2/25.2/1.2' 505g

Sheet metal bending pliers

9M0301 / 9M0302 / 9M0303



9M0301



9M0302



9M0303

- Easy to do the automobile body work

Part No.	Description	Length	Packing	g
9M0301	Straight	280mm (11")	20/13/14/0.96'	650
9M0302	45 Degrees	280mm (11")	20/13/14/0.96'	650
9M0303	90 Degrees	280mm (11")	20/16/17/0.96'	800

Welding clamp

66201



- Size: 9"
- Cr-mo jaws
- Bodily heat-treated
- Welding brazed
- Nickel plated
- Function: clips things by the two flat pieces in front of the clamp.

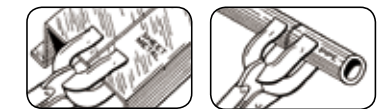

40/24.8/25.8/1.4' 620g

Welder's Flat Grip Wrench

65203

- Especially designed for the pipe welding.
- Length : 11" / 270mm

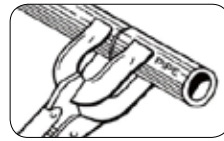

6pc Self-locking multi-grip pliers set

50635

Contents:

- 67901 Wide flat jaws
- 67902 Double curved jaws
- 67903 Wide curved jaws
- 67904 Angled jaws
- 67905 Straight jaws
- 67906 Mini straight jaws



3/13.5/14.5/1.5' Δ 4520g

Self-locking multi-grip pliers Wide flat jaws

67901

- Chrome-plated
- For spot welding
- Length:200mm



36/21.6/22.6/1.9' Δ 620g



Self-locking multi-grip pliers Double curved jaws

67902

- Chrome-plated
- For assembling angular shapes
- Length:200mm



36/21.1/22.1/1.1' Δ 586g



Self-locking multi-grip pliers Wide curved jaws

67903

- Chrome-plated
- For spot welding of metal sheets with 90° angled edges
- Length:200mm



36/21.6/22.6/1.1' Δ 620g



Self-locking multi-grip pliers Angled jaws

67904

- Chrome-plated
- For 90° edged metal sheets
- Length:210mm



36/18.2/19.2/0.97' Δ 505g



Self-locking multi-grip pliers Straight jaws

67905

- Chrome-plated
- For flat metal sheets
- Length:200mm



36/17.2/18.2/0.97' Δ 478g



Mini straight jaw

67906

- Chrome-plated
- Clamp two sheet metal pieces of equal thickness at 90°.
- Jaw adjustment: 0-12mm
- Length:200mm



36/18.0/19.0/0.97' Δ 500g



Plug weld pliers

9U0101



- Copper alloy backing plate prevents burning through. (Weld will not stick to the copper alloy)
- Warning:** Always wear ANSI approved safety goggles when working with tools and equipment.

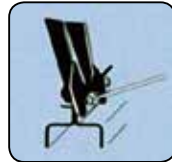

16/24.2/25.2/1.7' 505g

Air spot weld drill kit

910M5



- Ideal for speedy removal of spot welds on vehicle bodywork.
- Two-tier planetary gear system triples the output torque to meet the requirement of drilling high-strength body material BTR, BOR and USIBOR etc.
 - Control collar (feeding adjustable ring) allows precise setting of drilling depth.
 - The Brace & Feeder Assembly can be rotated 360 degree and removed, and also prevent side-slipping of drill when working.
 - With one piece of HSS drilling bit (8mm shank x 8.0mm)
 - Contents :
 - 1pc - Air spot weld drill with 8mm drill bit.
 - 5pc - HSS-Co Drill bits:3pc 8mm and 2pc 6.5mm.
 - 1pc -2mm Hex key
 - 1pc - Oil pot
 - 1pc - Air regulator
 - 1pc - 1/4" Air nipple

6/15.7/16.7/1.54' 2617g

Punch tool

9M0105



- Punch hole : 5mm diameter
- Steel thickness 1.1mm

16/19.0/20.0/1.1 1100g

Flanger / Punch combo tool

9M0106



- Punch hole : 6mm diameter
- Steel thickness 1.1mm



16/18.0/20.0/1.1' 1150g

Auto body repair pull clamp

62501



- Single direction action
- Capacity: 5 tons



10/19.4/20.4/0.6' 1940g

Auto body repair pull clamp (two way)

62502



- Two direction action
- Cross capacity: 2 tons
- Longitudinal capacity: 5 tons

10/21.0/22.0/0.6' 2100g

Auto body repair pull clamp

62503



- Single direction action
- Capacity: 3 tons

10/20.1/21.1/0.65' 2kg

Auto body repair pull clamp

62504



- Single direction action
- The two side heights of jaw surface are not even, most suitable for narrow space application.
- Capacity: 3 ton

10/20.1/21.1/0.88' 2kg

Auto body repair pull clamp (two way)

62505



- Two direction action
- The two side heights of jaw surface are not even, most suitable for narrow space application.
- Cross capacity: 2 ton
- Longitudinal capacity: 3 ton

10/20.1/21.1/0.94' 2kg

Auto body repair pull clamp

62506

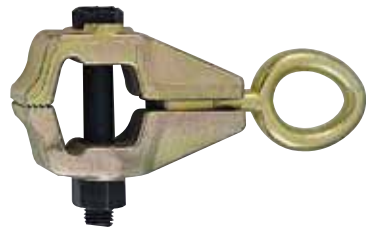

- Single direction action
- Capacity: 5 ton

6/13.4/14.4/0.71' 2230g

Auto body repair pull clamp (tight opening)

62529



- New design tight opening clamp.
- Single direction action.
- Capacity: 3 tons.
- Jaw open: 35 mm.

10/12.0/13.0/0.5' 1200g

Auto body repair pull clamp (C type)

62507



- Multi-direction action
- The jaw surface can be extended about 3" (75mm).
- Capacity: 4 ton

5/15.2/16.2/1.1' 3017g



Auto body repair pull clamp (C type)

62508



- Multi-direction action
- The jaw surface can be extended about 6" (150mm).
- Capacity: 4 ton

4/19.5/20.5/1.4' 4875g

Long nose pull clamp

62509



- Single direction action.
- Long jaw mouth is most suitable for narrow space application.
- Capacity: 1 ton

10/16.6/17.6/0.67' 1660g

Scissor pull clamp

62510



- Single direction action.
- No need screw for locking.
- During operation it will lock as well as tightly.
- Capacity: 3 ton

6/15.0/16.0/0.71' 2500g

Auto body repair pull clamp

62511

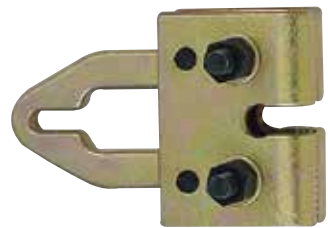

- Single direction action.
- The jaw surface is 120mm long, most suitable for thin sheet application.
- Capacity: 5 ton

6/15.1/16.1/0.71' 2520g

Auto body repair pull clamp (two way)

62512



- Two direction action.
- The jaw surface is long 120mm, most suitable for thin sheet application.
- Cross capacity: 3 ton
- Longitudinal capacity: 5 ton

6/17.3/18.3/0.71' 2880g

Auto body repair pull clamp (three way)

62513



- Universal direction action
- The jaw surface is 120mm long, most suitable for thin sheet application.
- Cross capacity: 3 ton
- Longitudinal capacity: 5 ton
- Multi-direction capacity: 3 ton

6/19.6/20.6/0.71' 3260g

Utility claw hook

62514



- Applying for connecting and shortening the chain. (3/8" and 5/16" chain applicatory)
- Capacity: 6 ton



20/24.4/25.4/0.6' 1220g

Twin pull hook

62515



- Applying for two clamps are connected by a chain and make a two sides action. (3/8" and 5/16" chain applicatory)
- Capacity: 6 ton



10/10.8/11.8/0.32' 1080g

Body jig chain connector link

62516

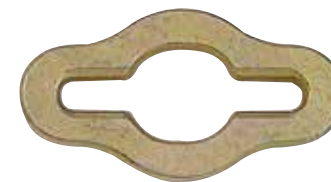

- Applying for connecting and shortening the chain. (3/8" and 5/16" chain applicatory)
- Capacity: 6 ton



10/6.3/7.3/0.32' 630g

Self-tightening clamp

9M1601



- Minimum size, maximum capability for tight places.
- Responsive, spring-loaded, one-handed application for fast action pulls.
- Round wedge allows chain to be pulled free of twists.
- Aggressive cross-hatched tooth design.
- Capacity: 5 ton

15/16.5/17.5/0.59' 1100g

Self-tightening clamp

9M1602



- Self-tightening clamp; grips tighter as it is pulled.
- Compact and lightweight for pulling from many places.
- Minimum of 1-1/2" reach-around for flanges, cowls, pinch welds, and lips.
- Butts against panels where only narrow bite available.
- 1-1/4"(31.8mm) jaws give added grip.
- Capacity: 6 ton



8/18.0/19.0/0.56' 2250g

Self-tightening clamp

9M1603



- Self-tightening: The harder it's pulled, the tighter it grips.
- Heat-treated steel clamp is positioned on work with wedge forward and nut just finger tight.
- Easy to attach no special wrench needed.
- 2-1/4" (57.2mm) jaws
- Capacity: 6 ton



6/18.7/19.7/0.56' 3120g

Right angle clamp & yoke

9M1604



- Capacity: 6 ton on straight way
3 ton on cross way
 - Two-way pull operation
 - Serrate width: 100 mm
- You can make straight and right angle pulls with this clamp. Replaceable hardened steel jaws com as standard.

4/16.0/17.0/0.49' 4000g

Right angle clamp & yoke

9M1605



- Capacity: 6 ton on straight way
3 ton on cross way
 - Two-way pull operation
 - Serrate width: 100 mm
- You can make straight and right angle pulls with this clamp. Replaceable hardened steel jaws com as standard.

4/16.3/17.3/0.49' 4075g

Pull clamp

9M1606



- Capacity: 6 ton on straight way
 - Single-way pull operation
 - Serrate width: 100 mm
- You can make straight and right angle pulls with this clamp. Replaceable hardened steel jaws com as standard.

4/13.0/14.0/0.6' 3250g

Pull clamp

9M1607



- Capacity: 6 ton on straight way
 - Single-way pull operation
 - Serrate width: 100 mm
- You can make straight and right angle pulls with this clamp. Replaceable hardened steel jaws com as standard.

5/16.2/17.2/0.46' 3240g

1 ton Portable puller

88201

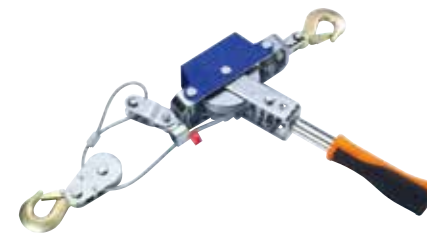

- Detachable Handle with ergonomic design.
- Stores in a handy case and easily under a pick-up seat or straps to a luggage carrier.
- Capacity: 1 ton (2000 lbs)
- Cable: 5mm x 10ft with 2 hooks

6/20.4/21.9/2.0' 3400g

3-in-1 Super duty orbital air sander

82603



- Machine description:3-in-1
- Paper size:6" (152 mm)
- Free speed:10000 R.P.M
- Orbit option:5.0 mm
- Overall length:8-55/64"(225 mm)
- Air inlet:1/4" P.T.
- Air hose:3/8 I.D
- Avg. air consumption:7.5cfm (212 L/min)
- Net weight:1.8 Lbs (0.82 kgs)

12/9.0/13.0/2.5' 815g

Adjustable body file blade holder

65701



Application: for 14" (350mm) flexible file adjustable frame.

20/15.7/16.7/2.1' 785g

Body file blade

65714



Part no.	teeth per inch	inch	Packing	g
6571409	9	14	60/18.6/19.6/0.5'	310
6571412	12	14	60/21/22/0.5'	350

4pc Body filler applicator set

904M7



- Flexible spring steel blades
- Ergonomic composite handles with rubber comfort grips
- Perfect for application of body fillers in automotive restoration.
- Set includes: 2", 3", 4" & 6" blade sizes.

40/9.0/10.0/2.8' 240g

5pc Needle file set

50513



Set of 5pcs needle files with different shapes. Smooth cut. Needle files shapes round, square, half-round, triangular, and flat.

120/10.8/11.8/0.9' 90g

5pc Auto body tools

T905M2



- Contents:**
- 905M2P1 1-Trim pad remover (big)
 - 905M2P2 1-Trim pad remover (small)
 - 905M2P3 1-Gasket scraper
 - 905M2P4 1-Radiator hose remover
 - 905M2P5 1-Cotter pin puller

6/5.0/6.0/0.65' 833g

4pc Composite scraper set

904M6

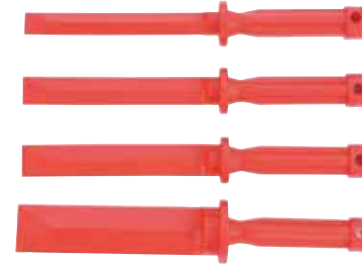

- Ideal for removing trim, badges and decals from bodywork.
- Also suitable for removing residue from alloy wheels.
- Polypropylene edges will not scratch or mark paint or panel work and can be re-sharpened with a file when required.
- Length: 270mm
- Blade Size: 19mm(3/4"), 22mm(7/8"), 25mm(1"), 38mm(1-1/2")

20/10.0/11.0/3.6' 500g



Plastic riveter set

67803



- Rivet sizes:10pcs each 5mm×15.8mm / 5mm×17.2mm / 6mm×17.2mm / 6.3mm×25.2mm.
- Save time:set different sizes of rivets without changing nose pieces.
- Wide range application:perfect for working on automotive plastic bumpers, wheel wells, etc.
- Set plastic rivets perfectly in a single stroke by using this tool which has self adjusting jaws.
- Avoid damaging painted and delicate surfaces by using this specialty tool.
- Provides extra access to hard to reach areas.

20/15.5/17/2.2' 775g

4pc Door service tool set

904M1



- A handy tool set which includes a door handle tool, two door panel removers and a GM door trim pad remover.
- Together they handle a wide range of service applications.

24/13.4/14.9/2.7' 560g



5pc Handy remover set

905M1



- For plastic upholstery fastener.
- Place tool under edge of door panel and insert into fastener as far as possible and then simply pull up.



48/19.3/20.3/3' 400g

4pc Trim Removal set

904M3



- The most versatile body/interior tool set we have ever carried. Nearly indestructible, non-marring composite construction.
- Great for technicians, body shops, upholstery shops.

72/6.9/7.9/1' 200g

BENZ Wedge set

9M0203



- Used to safely remove the wood & plastic pieces on the door panels as well as on the dashboard, without damage it.
- Application: All Mercedes Benz.



200/10.7/11.7/0.3' 53.5g

Clip removal pliers

9M0101



For removal of door inner-linings and other trim items held in place by plastic rivets.



72/17.3/18.3/3.8' 240g

Clip removal pliers

9M0102



- Designed to remove broken rivets (plastic), used under care cover or door pannel.
- Can adjust the angle from 0°~90°.

24/11.6/12.6/2.6' 480g



2pc Clip removal pliers set

902M1



- Removal for all types of clips
- The front ends of the tool are angled and tapered to fit easily under a clip.
- Size: **9M0103**-35°
9M0104-80°

48/18.0/19.0/3' 375g



2pc Clip remover

902U1



- Engage the tool tip behind the connector clip.
- Push or pull to disconnect.
- Works on Weather Pack and other automotive electrical connectors.

96/14.4/15.4/1.7' 150g

Mini clip pliers

902M3



- Special design to use on small space
- Size: 20mm x 100 mm
26mm x 100mm

96/14.4/15.4/1.7' 150g

44pc Auto glass maintenance set

944M1



- 1pc Wire piercing tool
- 1pc Square cutting wire
- 1pc Cutting wire
- 1pc Cutting wire (golden color)
- 2pc Wire handle
- 1pc Window clip molding remover
- 2pc Double suction cup (dia. 12cm) swiveling heads w/hole
- 1pc Window molding remover
- 1pc Wide pinch weld scraper
- 1pc Sharpening stone
- 1pc 18" Urethane cutting knife & blade
- 1pc Gasket scraper
- 1pc Door cover clip remover
- 1pc Standard cold knife
- 28pc Standard cold knife blade



2/12.0/13.0/3' 6kg

13pc Auto glass maintenance kit

K913M1



- Contents:**
- 9M0503 Windshield cut-out wire (stainless steel, square)
 - 9M2901 Wire guide
 - 902M2 2pc Wire gripping handles (Quick release)
 - 9M2902 Wire starter
 - 9M2903 Music wire piercing tool
 - 5055P401 Utility knife
 - 5055P401-P 5pc Spare blades for 5055P401
 - 9U2102 Scraper with dual-material grip (12mm blade)
 - 9U2102-12 5pc Blade 12mm
 - 9U2102-16 5pc Blade 16mm
 - 9U2102-16A 5pc Blade bevelled 16mm
 - 9U2102-20 5pc Blade

6/12.2/13.2/1.5' 2035g

4pc Windshield removal kit

904M5

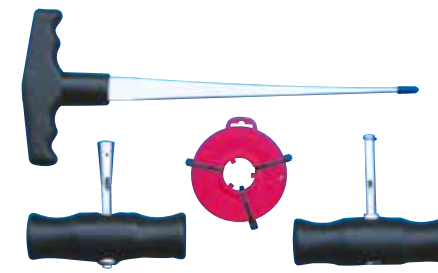

It is ideal and essential kit for removing the vinyl adhesive compound around windshield.

Contents:

- **Wire feeder tool (Length: 205mm)**
Designed for easy and flexible insertion of wire through polyurethane, allowing speedy removal of bonded windshield.
- **2pc Wire gripping handles**
Feed the wire through the hole in the wedge shaft. Loop it through the hole at the top of the shaft. Then back into the handle. Pressing the wedge back into the handle, the wire is held.
- **72 feet Square wire**
Material: Stainless

32/14.0/15.0/2' 437g

7pc Windshield removal kit

907M1



- **Wire**
Material: stainless
- **2pc Wire gripping handles**
Feed the wire through the hole in the wedge shaft. Loop it through the hole at the top of the shaft. Then back into the handle. Pressing the wedge back into the handle, the wire is held.
- **Windshield removal tool**
Cuts the vinyl adhesive compound around windshield.
- **Wire feeder tool**
Designed for easy and flexible insertion of wire through polyurethane, allowing speedy removal of bonded windshield.
- **Trim pad remover**
Place the tool under the edge of the door upholstery panel and insert it into the fastener as far as possible, then simple pry up.
- **Windshield molding release tool <for GM>**
Use for removal of windshield molding on rubberless installation.

6/6.5/7.5/1.5' 1083g

10pc Windshield installation kit

910M3



- **Rope insert tool**
Use this tool to insert the rope into rubber gaskets. The handle feeds rope through its stem as you pull it around the gasket.
- **Assort tip for insert tool**
For inserting locking strip into windshield seal. Different shaped heads interchangeable for most types of locking strip.
- **Curved hook tool**
Curved hook tool used for inserting and cleaning rubber gaskets.
- **Straight hook tool**
Straight hook tool used for inserting and cleaning rubber gaskets.
- **Cleaning tool**
Designed for the removal of broken glass for the side runners without removing them.



6/5.4/6.4/0.75' 895g

Windshield cut-out wire (stainless steel, square)

9M0503



- Designed to provide the fast cutting action possible.
- Each wire acts like a cutting saw tooth.
- Made of stainless steel 50m per roll.

96/18.3/19.3/1.5' 190g

Windshield cut-out wire (stainless steel braided)

9M0505



- Designed to provide the fast cutting action possible.
- Each wire acts like a cutting saw tooth.
- Made of stainless steel 50m per roll.

96/20.0/21.0/1.5' 125g

Windshield removal tool

9M2904



- Cable action makes cutting out windshields fast and easy.
- A strong tempered steel blade, sharpened to a fine cutting edge, with a large durable aluminum handle, combined with a steel cable pull handle assures the easiest and fastest way of cutting the caulking compound around the windshield.
- The steel cutting blade can be re-sharpened and after many uses is easily replaced with a new blade.



48/14.0/15.0/1.4' 290g

Window scraper

9U2101



- Special handle design for easier grip when operation.
- Replaceable blade design to change the blade quickly and easily.
- Blade width: 40mm



144/17.2/18.7/2.3' 120g

Multi-function powerful suction cup

634



- To pull up the plating notched part.
- To fix the windows while maintaining.
- To assemble the front and rear wind broken glasses.



Part no.	Application	Packing	Capacity	
			Kgs	g
63401	On flat object	20/7.9/5.9/1.6'	50	395
63404	Fixed 2 sucker	20/24.3/25.3/4'	80	1215

Multi-function powerful suction cup (Aluminum)

634..A



- To pull up the plating notched part.
- To fix the windows while maintaining.
- To assemble the front and rear wind broken glasses.

Part no.	Application	Packing	Capacity	Kgs	g
63401A	On flat object	20/10.9/11.9/1.6'	30	480	
63403A	Fixed 2 sucker	20/20.1/21.1/1/4'	50	780	
63404A	Flexible 2 sucker	20/24.4/25.4/4'	35	1180	
63405A	Fixed 3 sucker	10/14.1/15.1/3.1'	100	1410	

33pcs Paintless dent repair kit

933M1



- Hail damage, door dings and other cosmetic damage are quickly massaged out with this extensive 33pc tool profit center.

2/17.5/18/1.6' 8.5kg

Air inflator for unlocking car door (vehicle)

9M2301



- This inflation design easily and safely to separate the door frame from the vehicle body.



20/4.8/5.8/2.4' 200g

Windshield stand (folding type)

9M3401



- The most common complaint about windshield stands is the amount of space they take up.
- To collapse the stand, pull each of the legs apart and fold them toward the center.
- Each leg is held together by a steel rod that gives the stand greater strength than it would have if it did not have the rods.
- Size:24"



1/9.0/10.0/1.3' 9kg

5pc Wiper arm puller set

905M5



- Universal applications
- Provide 4 adjustable removers & one high versatility puller fits nearly all difficult wiper arm removing works.

10/11.7/12.7/1.27' 1170g



Easy lock wiper arm remover tool

9M0207

NEW



- Easy lock action allows a fast snap to wiper arm saving huge amounts of time.
- Can be used on a variety of applications.
- Suitable for use on 99% of vehicles.
- Capacity: 0~30mm



■ Windscreen wiper arm removal tool

9M0201



- The compact design offers easy access in confined spaces and eliminates the risk of damage to the wiper arm or surrounding paintwork.
- A simple, effective tool allowing easy removal of those stubborn wiper arms. Suitable for both taper and taper spline spigots.
- Size: 16mm×32mm



48/6.8/7.8/1'

140g

■ Windshield wiper arm removal tool

9M0202



- Tool removes wiper arms for most of the vehicles.
- Protective pad on bottom jaw will not scratch painted surfaces. Place jaws between wiper arm and shaft and squeeze handles to remove.



72/20/21/3.6'

278g

■ Locking cylinder assembly sleeve

9M0108



NEW

- Suitable for the quick and exact repair of the door lock.
- For inside track closure with internal spring.
- Application range: Volkswagen - Passat, Vento, Beetle, Lupo, Golf 4 (not Cabrio), Seat, Škoda etc.

48/6.8/7.8/1'

140g

6. Motorcycle



Flywheel puller tool

Page 6-1 ~ 6-3



Valve / Piston / Oil filter tool

Page 6-8 ~ 6-10



General tool

Page 6-13 ~ 6-18



Clutch holder tool

Page 6-4 ~ 6-4



Timing tool

Page 6-10 ~ 6-11



Motorcycle fork / Carburetor tool

Page 6-4 ~ 6-6



Wheel nut tool

Page 6-11 ~ 6-12



Chain / Belt tool

Page 6-6 ~ 6-7



Brake tool

Page 6-12 ~ 6-13

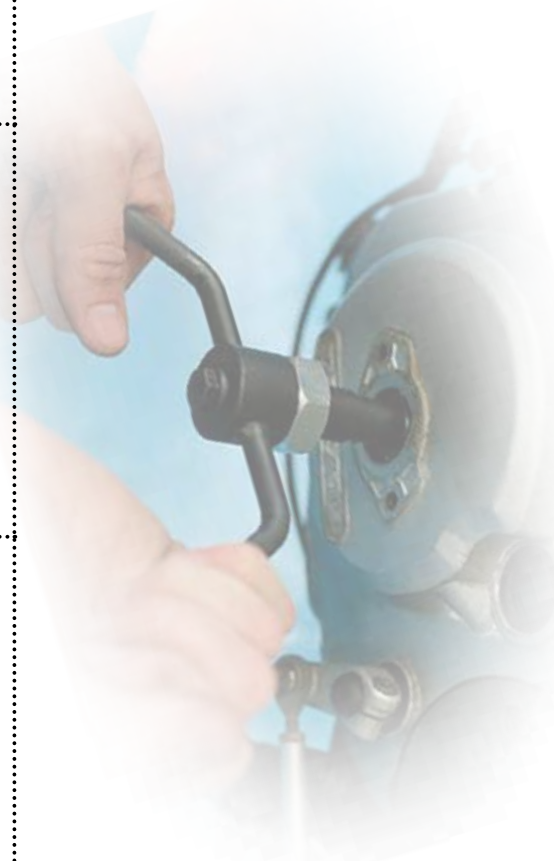

10pcs Motorcycle flywheel drive puller set

909Y1



- Thread Sizes:
85mmL
M14xP1.5; M16xP1.5; M18xP1.5
65mmL
M19xP1.0; M28xP1.5;
M20xP1.0 / M27xP1.25; M22xP1.0 / M25xP1.5;
M22xP1.5 / M26xP1.5; M24xP1.0 / M27xP1.0L;
M26xP1.0 / M28xP1.0
- Application:
YAMAHA, SUZUKI, HONDA, BOSCH, DUCAN, GLERA,
SAM, CAGIVA, SFERA, KYMCO, MBK, PEUGEOT, KIMOO,
MOTOPLATT, KAWASAKI, KOKUSAN, MINARELLI, DUCATI.



10/17.8/18.8/1.15' 1780g

Motorcycle flywheel puller M27x1.5

9Y0182



- Designed to remove the motorcycle flywheels.
- Puller includes M27x1.5 right hand internal threads, M12x1.25 crankshaft protector cap.
- Application:
Honda: CG125 / ML / BIZ100 / POP100

60/20/21/1.1' 333g

Motorcycle flywheel puller M30x1.0

9Y0183



- Designed to remove the motorcycle flywheels.
- Puller includes M30x1.0 right hand internal threads, M12x1.25 crankshaft protector cap.
- Application:
Yamaha: WR 250F 2003 – 2008 and WR 450F 2003

60/25.5/26.5/1.1' 425g

Motorcycle flywheel puller M30x1.25

9Y0185



- Designed to remove the motorcycle flywheels.
- Puller includes M30x1.25 right hand internal threads, M12x1.25 crankshaft protector cap.
- Application:
Honda: CRF450X, CRF450X8

60/25.8/26.8/1.1' 430g

Motorcycle flywheel puller M30x1.5

9Y0186



- Designed to remove the motorcycle flywheels.
- Puller includes M30x1.5 right hand internal threads, M12x1.25 crankshaft protector cap.
- Application:
Honda: Most 1989-1990 FL400R pilot models.
Kawasaki: Some KLF300 quad models.
Suzuki: Most LT160/230/250, TM125/250/400, 1970's TS250, 2004-2009 DR200 enduro models and most early PE, TS models.
Other: European CZ MX and enduro models.

60/25.4/26.4/1.1' 424g

Motorcycle flywheel puller M28x1.0

9Y0188



- Designed to remove the motorcycle flywheels.
- Puller includes M28x1.0 right hand internal threads, M12x1.25 crankshaft protector cap.
- Application:
Honda: CRF450X 2004-2008, TRX450R/ER 2006-2007
Kawasaki: 2008 K LX450R
Suzuki: 2008 RMZ450

60/17.2/18.2/1.1' 287g

Motorcycle flywheel puller M26x1.0

9Y0187



- Designed to remove the motorcycle flywheels.
- Puller includes M26x1.0 right hand internal threads, 12mm shaft protector cap.
- Application:
KTM: 250 RFS, 250SX-F, 400, 450, 520, 525

60/12.8/13.8/1.1' 213g

Motorcycle flywheel puller T bar M27x1.0

9Y0181



- Designed to remove the motorcycle flywheels.
- Size: M27x1.0.
- Applicable:
Honda: CR80R/125R/250R/450R/480R/500R, XL80/100/100S/170, XR100/100R, XR50/CRF50 00-04, FL250, ATC70/110 (CDI ONLY), ATC185/ 250R, TRX250R 86-89, TRX90 93-00, TRX70/125 & EARLY 50cc
Suzuki: 125/160EK/250R, DR100/125/200, DS80, ALT185
Yamaha: 1968 & later, BW80, RIVA50, PW50, RZ350, TT500, XT500, YFM80/100/200/225, YFS200, YFZ350, YSR50, YT125/175 & YZ400F, YZ450F
Kawasaki: KD/KX/KDX80, KM100, KS100, KS125
KTM: 65SX 99-04, 85SX 04, 105SX 04, 200 EXC/MXC 98-05, 125/250 SX/EXC/MXC 98-05 & 250/300/380 SX/EXC/MXC 97-05

60/15.0/16.0/1.0' 250g

Flywheel puller for DUCATI

902Y1



- Designed to remove the motorcycle flywheels.
- Applications: Ducati 250/350/450 and most later bevel single wide-case models.

24/12.0/13.0/0.7' 500g

Clutch holding tool

9Y0101



- Made from medium carbon steel with hardened jaws
- Holds clutch hubs, flywheels, gears, sprockets, etc...
- Features spanner pins
- Jaws open to 5" wide

20/14/15/1.2' 700g



Rotor and sprocket holder

9Y0111



- Keeps flywheels, rotors and sprockets from rotating during removal and installation.
- Holds sprockets and rotors with holes center-to-center at a minimum distance of 1/2" (13mm) and a maximum distance of 9" (230mm).
- Features 5mm and 9mm pins.
- Adjustable stop screw keeps tool open at set distance.

36/20.5/22.0/2.1' 569g



Universal fork seal driver

903Y1



- Designed for easy installation of most fork seals.
- Works on either conventional or inverted forks.
- Unique adjustable insert will work on dia. 26 to 45mm.

20/22.0/23.0/0.7' 2200g



Motorcycle fork cap wrench (46x50)

9Y0121



- For removing the fork caps on late-model RMs & CRs
- Can be used for removal of a compression stack on late-model RMs
- Replaces Suzuki OEM 09941-53630
- One end is 46mm, the other is 50mm
- Also fits 2010 Honda CRF250R

48/16/17/0.74' 334g



Fork compression valve removal tool

9Y0122



- Ideal tool to remove the compression valve from cartridge.
- 19mm drive hex with 36 mm octagon.
- Made of 6061-T6 aluminum.
- Applications:
Honda: CRF250R 2010-2012, CRF450R 2009-2012,
Kawasaki: KX 450F 2009-2012
Yamaha: YZ 125/250 2005-2012, YZ 250F/450F 2006-2012

144/7.5/9.0/1.5' Δ 52g

Twin chamber KYB compression valve wrench

9Y0146

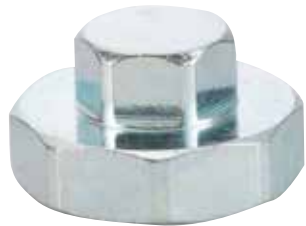

- This tool removes the Compression Body from the cartridge on twin-Chamber KYB forks.
- Applications:
Yamaha: YZ 125/250 05-09, YZ250F/450F 06-09

144/17.0/18.5/1.0' Δ 118g



3/8"DR. Fork damper rod holder

9Y0123



- Ideal tool to hold damper rod when disassembling and assembling front forks.
- It provides a secure method of holding the inner damper rod while removing the bolt from the bottom of the fork leg on Kawasaki models.
- Applications: KZ, ZS, KX and KDX front fork dampers.

96/14.5/16.0/1.3' Δ 151g



Angle driver for motorcycle carburetor

910Y1



- Deep-access tool particularly suited to adjustment of motorcycle carburetor.
- One turn of handle equals one turn of blade.
- 90° and straight gear-boxes.
- Furnished with set of driver bits.

12/11.0/12.0/2.1' Δ 916g

Carburetor synchronize tool set

919G2



- For testing fuel pump carburetor and transmission check auto with 2~4pc carburetors.
- Gauge: Pressure: 0~15 PSI: 0~1 kg/cm²
Vacuum: 0~28 in-Hg (0~70 cm-Hg)
- Contents:
4pc 3-1/2" Synchronizer gauges with fixed plate
4pc Rubber hose 8 X 5 x 750mm
4pc Extension tube 3.9 x 52mm
4pc Extension tube 3.9 x 122mm
8pc Cone type connector 8 x 40mm
4pc Adapters 10 X 53mm (M6 x 0.75)
4pc Adapters 10 X 60mm (M6 x 1.0)

6/20.0/21.0/2.25' Δ 3330g



All purpose chain separating tool

9Y0135

- For pressing rivets out of the chains.



24/18.5/19.5/1.6' Δ 770g

Chain breaker and riveting tool set

913Y1



- Versatile 3-in-1 tool can be used on both cam chains and drive chains.
- The kit supplied with adequate components to break chains from #35 to #630.
- Includes three pin sizes for compatibility with most chains (2.2 mm, 2.9 mm & 3.8 mm) .
- Also includes tools and plates needed to rivet hollow nose master links.

20/16.5/17.5/1.5' Δ 825g



Chain link pliers

9Y0131



- Designed to simplify installation or removal of clip-type master chain links.



48/16.9/7.9/2.3' 143g

Chain puller tool

9Y0132



- This chain puller is made for work on drive chains found on motorcycles and all-terrain vehicles (ATVs).
- Tightening the forcing screw pulls the jaws together to hold the chain for easy removal or installation of the chain connector or master link.



48/12.0/13.0/2' 252g

Motorcycle chain brush

9Y0133



- Composite, angled chain brush features adjustable brush adaptors to fit various size chains.
- Suitable for use on all chain types.



72/8.5/10.0/3.6' 118g

Motorcycles belt tension gauge

9Y0141



- This tool can be used to adjust belt tension on most motorcycles equipped with a secondary drive belt.
- This tool provides a simple way to firm the belt for proper tension.



240/18.0/19.5/1.6' 75g

Tappet adjusting tool set

9Y0142

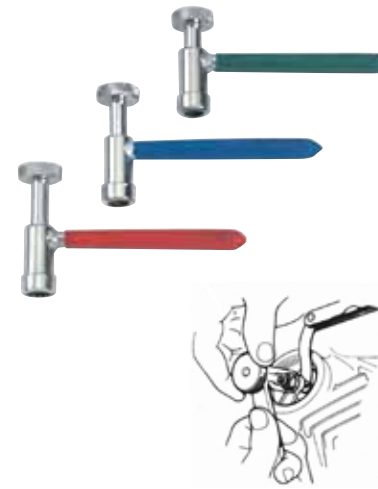

- Set contains three wrenches (8, 9 & 10mm) and three adjusters (screw type and 3 & 4mm square type).
- Interchangeable adjusters and wrenches provide nine different combinations.
- Ideal for most marks and models of motorcycles, ATVs and ATCs.
- Applications:
HONDA: All ATC's and motorcycles with 4-cycle engines and screw type adjusters.
YAMAHA: SR 185/250, XT/TT250, XS400, ST185
SUZUKI: All 4-cycle ATV's and motorcycles with screw-type adjusters.
Any tappet adjuster with 8, 9 or 10mm adjusting nut and 3 or 4mm square slotted adjuster.

48/12.5/13.5/0.6' 260g

Large tools work on valves of 4-valve-per-cylinder heads

9Y0143



- Used to install valve spring keepers.
- Replaces the large cumbersome valve spring compressor.
- These tools are aimed at saving time when replacing valves in modern 16 to 20 valve head.
- Designed to fit the valves of 4 -cylinder heads (5.5 mm valve stem diameter or larger with under 40 lbs).



36/13.0/14.0/0.6' 361g

Small tools work on valves of 4-valve-per-cylinder heads

9Y0143B



- Used to install valve spring keepers.
- Replaces the large cumbersome valve spring compressor.
- This tool is designed to save time in replacing valves of modern 16 to 20 valve heads.
- This tool works on valves of 4- or 5- valve-per-cylinder heads. (Valve stem diameter of 5mm or smaller)

36/15.0/16.0/0.6' 420g

Valve spring compressor

62110



- These tools are designed to compress and release valve spring after removing the collets. Pantograph-type levers ensure a consistent coaxial contact with the valve.
- Contents:
3pc Driving adaptor: 16; 19; 23; 25; 30 mm
3pc pressure screw: 70mmL; 110mmL; 120mmL
1pc C Clamp



10/21.5/22.5/2.2' 2150g

Piston ring pliers

62002



- Save by reducing ring breakage.
- Tapered jaws to remove and install most passenger car and light truck rings from 3/64" to 1/4" (1.2mm ~6.3mm).



144/18.0/19.0/2.15' 135g

Piston ring compressor tool

62005



- Designed to prevent ring breakage during cylinder installation.
- It can easily be removed after cylinder is in position.
- Tool supplied with 6 rings to be applicable to most engine sizes.
- Fits 35-73 mm

60/16.23/17.23/2' 270.5g

Piston ring compressor for Motorcycle

6202080



- For easy insertion of piston into cylinder bore and even compression over full ring length.
- Ratchet mechanism.
- Capacity: 40 - 80 mm diameter.

50/7.0/8.0/0.89' 140g

Oil filter wrench

9B0701



- Steel jaw grips filter without slipping.
- Use with 3/8" drive.
- Suitable for filter 2-1/2" to 3-1/8" (60m/m-80m/m).



48/18.1/19.1/1.7' 380g

Timing and crankshaft turning tool for DUCATI

9Y0301



- Ideal tool to turn timing mark on the degree wheel for perfect valve adjustments.
- It makes ignition timing work to be performed well.
- Applications: DUCATI Monster | Multistrada 600 / 620 / 748 / 750 / 800 / 848 / 851 / 888 / 900 / 916 / 996 / 998 / 999 / 1000 / 1098 / 1198.



36/18.0/19.5/1.9' 500g

Engine rotating tool for DUCATI

9Y0302



- It allows you to rotate your engine easily and safely while checking the valve clearances or setting the timing.
- Applications: DUCATI Monster /748/996/999/SS.



96/12.5/13.5/0.6' 130g

Timing and crankshaft turning tool for DUCATI

9Y0303



- It allows you to attach through the primary cover access hole and fit into the crankshaft notch for ignition timing work accuracy.
- It is also suitable for mounting most available degree wheels.
- Applications: Ducati 250/350/450/750

36/14.5/16.0/1.1' 403g

Cam holder for DUCATI

9Y0305



- This tool helps you to loosen the cam gear nut easily.
- Applications: DUCATI 250 350 450 750 single twin bevel.

20/19.2/20.2/0.43' 960g

Spark plug cap removal tool for BMW

9Y0306



- This tool works on R and F series coil-over bikes.
- It is designed to slip onto the cap from the front and that allows you to remove the spark plug cap without damaging it.
- If the cap is very difficult to remove, choose a proper bar, slip it through the 1/4" hole on the tool and then you can pry the cap loose easily.
- Applications:
All R1150 from Dec 2002 production
R1200C, R1200C I/M, R1200 Montauk from October 2002 production
All R1200 from model year 2003 and newer
R1100S from December 2002 production
All F Twins
All G Thumpers
All new style K1200/1300s



144/7.5/9.0/1.8' 52g

4-in-1 Hex axle tool

9Y0151



- Fits internal hex on many late-model sport-bike axles and some dirt bikes.
- Four metric hex sizes: 17, 19, 22 and 24mm.
- 3/8 in. square drive on both ends.
- Applications:
BMW: 1200GS, R1200 RT
Buell: XB9R, XB9S, XB12R, XB12S (2003-2004)
Honda: CBR600RR, CBR1000RR
Kawasaki: ZX6R, ZX6RR, ZX600E/K, ZX7R, ZX9R, Z1000
Suzuki: GSXR 2000-2004, DL 1000 V-Strom (all), SV1000
Yamaha: R1, R6



100/17.0/18.0/0.6' 170g

Motorcycle spindle tool

9T1403



- Use a socket on the free end to remove spindle.
- 24mm for SUZUKI / HONDA
- 22mm for KAWASAKI
- 19mm for YAMAHA



100/13.6/14.6/1.5' 136g

Front and Rear wheel nut tool set

909Y2



- The combined socket is two sizes in one, a 55mm 12pt for the rear and a 28mm 6pt for the front.
- The other sockets size as follow:
41mm/46mm 6/12pt for the rear wheel
25mm/30mm 6pt and 28mm 12pt for the front wheel
- All sockets with 1/2" drive.



15/16.5/18.5/1.4' 1100g

Brake piston detaching tool for motorcycle

9Y0201



- To detach a piston from the disc brake base of a motorcycle
- Ratcheting handle allows the operator to replace a piston conveniently
- Jaw adjustment: 30-33 mm.
- Length: 240 mm.



10/13.5/17.6/2.1' 270g

Parking brake piston socket for YAMAHA

9Y0202



- Material: Heavy duty Cr-Mo steel construction
- Applications:
YAMAHA: MAJESTY (07~11), MAXAM (05~10), GRAND MAJESTY 400 (05~09), GRAND MAJESTY 250 (04~07), TMAX (05~10)

240/16.0/18.0/1.8' 67g

■ Parking brake piston socket for HONDA / SUZUKI

9Y0203



- Material: Heavy duty Cr-Mo steel construction
- Applications:
SUZUKI: SKYWAVE250 (07~11), SKYWAVE400 (07~11)
HONDA: FORZA (00~03)

240/14.0/16.0/1.8' 58g

■ Brake fluid bleeder bottle

9Y0161



- Bleeder Bottle Capacity: 0.5 L

50/10.0/11.0/3.0' 200g

■ Honda oil filter and clutch hub spanner

9Y0145



- Designed for oil filter and clutch hub on many Honda models (single-cylinder and twin-cylinder machines).
- 3/8" driver and 24mm inside diameter.
- Applications: most pre-1978 CB, CL, CT, SL and XL models, XR200 1980-1984, XR200R 1981-1994, XR250L 1991-1994, XR250R 1986-1995.
- Replaces large end of 077160020100 OEM tool.

240/12.5/14.5/1.6' 52g

■ Adjustable spanner wrench

9U0701



- For use on slotted retaining rings.
- Adjustable from 1/2" to 2-3/4".

48/16.1/17.1/1.1' 335g



■ Fixed type adjustable hook wrench

823

- For use on slotted retaining rings.



Part no.	Size	Packing	g
823035	15-35 mm	60/6.6/7.6/1'	110
823050	35-50 mm	60/12.6/13.6/1'	210
823080	50-80 mm	40/17.0/18.0/0.9'	425
823120	80-120 mm	20/15/16/0.92'	750
823180	120-180mm	12/17/18/1'	1400

■ Pin type adjustable hook wrench

823A

- For use on slotted retaining rings.

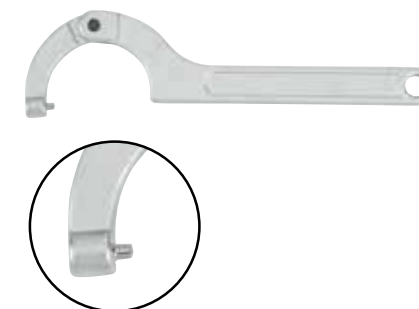

Part no.	Size	Packing	g
823A035	15-35 mm	60/6.6/7.6/1'	110
823A050	35-50 mm	60/12.6/13.6/1'	210
823A080	50-80 mm	40/17.0/18.0/0.9'	425
823A120	80-120 mm	20/15/16/0.92'	750
823A180	120-180mm	12/17/18/1'	1400

■ Internal snap ring pliers (long arm)

9U0102



- Special design for the retaining ring in the deep hole.
- The most deep size: 56mm.

48/9.5/11/2' 198g

■ Stud extractor

818A



- Socket 1/2" DR. Stud Extractor.
- For remove threaded, stripped, rusted, broken and smooth studs.
- Stud range: 6 - 19mm (1/4" - 3/4")

30/16.9/17.9/0.55' 560g



Hex nut driver T handle

774..A



Part no.	Tip	blade	over	g	pc/box
77406A	6	300	200	220	10
77407A	7	300	200	220	10
77408A	8	300	200	279	10
77409A	9	300	200	285	10
77410A	10	300	200	294	10
77411A	11	300	200	318	10
77412 A	12	300	200	432	10
77413 A	13	300	200	346	10
77414 A	14	300	200	422	10
77415 A	15	300	200	480	10
77416 A	16	300	200	510	10
77417 A	17	300	200	542	10
77418 A	18	300	200	600	10
77419 A	19	300	200	620	5
77420 A	20	300	200	650	5
77421 A	21	300	200	715	5
77422 A	22	300	200	715	5
77424 A	24	300	200	702	5
7741.4A	1/4"	300	200	220	10
7745.16 A	5/16"	300	200	279	10
7743.8A	3/8"	300	200	294	10
7747.16 A	7/16"	300	200	318	10
7741.2A	1/2"	300	200	342	10
7749.16 A	9/16"	300	200	422	10
7745.8A	5/8"	300	200	510	10
7743.4A	3/4"	300	200	620	5

Hex nut driver adjustable T handle

774..B

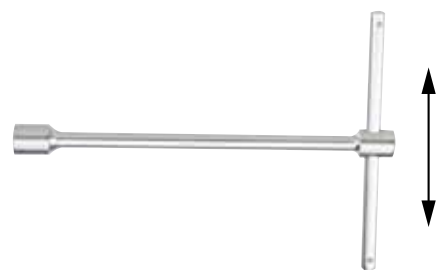

Part no.	Tip	blade	over	g	pc/box
77407B	7	220	200	190	10
77408B	8	240	200	195	10
77410B	10	260	200	265	10
77412B	12	260	200	380	10
77413B	13	260	200	380	10
77414B	14	260	200	385	10
77417B	17	290	250	500	5
77419B <small>NEW</small>	19	290	250	580	5
77422B	22	315	250	715	5

Tire lever

750



Part no.	Packing	Length	g
750200	100/14.6/15.60.56'	200	162
750300	120/31.6/32.6/0.6'	300	370
750380	60/22.9/23.9/0.5'	380	556
750380B	60/22.9/23.9/1.2'	380	560

12pc 3/8"DR. Impact socket set

3126



Part no.	Content:
82431	1-Impact wrench
8043 075...150 MPB	2-Impact extension 75, 150 mm
80531MPB	1- Universal joint (ball type)
80934MPB	1-Adaptor 3/8"(F)x1/2"(M)(ball type)
435 8...19	7-6pt. Flank impact socket 8, 10, 12, 13, 14, 17, 19 mm

6/15.6/16.6/1.54' 2600g

3-Drawer chest with 97pcs tools(Motorcycle)

50223S-97



1/19.87/20.87/2.2'



14pc Utility set

Part no.	Content:
6044190	1-Pin punch 4mm (190mmL)
6046210	1-Safe pin punch 6(210mm)
610B160	1-Long nose pliers
611B200	1-Combination pliers 8"
612B160	1-Diagonal pliers 6"
616200	1-Engineer hammer 200gw
61702	1-Flexible magnet pick-up tool
618	1-20pcs Feeler gauge set
6983	1-Technician's scissors 145mmL
750 300...380	2-Tyre lever 300mmL; 380mmL
88001	1-Round magnetic tray
88423	1-Car light tester Checks 6-24V system
9U3001	1-Brass & Nylon scrape brushes



60pc Combination set

Part no.	Content: 1/4" & 3/8" DR.
535 08...24	16-6pt. Flank socket (MM) 8; 9; 10; 11; 12; 13; 14; 15; 16; 17; 18; 19; 20; 21; 22; 24 mm
53546 08...14	5-6pt. Flank socket (MM) 8; 10; 12; 13; 14 mm
12125 0...3	4-Phillips bit PH.0; PH.1; PH.2; PH.3
12225 0...3	4-Pozidriv bit PZ.0; PZ.1; PZ.2; PZ.3
12425 03...08	6-Hex bit 3; 4; 5; 6; 7; 8 mm
5071	7-Star key
766 10...40	T10; T15; T20; T25; T27; T30; T40
5072	7-Hex key
764 025...10	2.5; 3; 4; 5; 6; 8; 10 mm
8013215	1-Swivel handle
802214	1-Mini bit ratchet
80233	1-Ratchet handle 24th
8033165	1-Sliding T bar
8043044...150	3-Extension 44mm(1.75") & 75mm(3") & 150mm(6")
80531	1-Universal joint
8073 16M... 20.6M	2-Mag. Spark plug socket 16 & 20.6 mm
81022M	1-Magnetic bit holder 1/4"(F)x1/4" in hex



10pc Waterpump pliers & Screwdriver set

Part no.	Content:
613B250	1-Waterpump pliers 10"
711 1B...3B	3-Phillips screwdriver PH.1x80mmL; PH.2x100mmL; PH. 3x150mmL
7112BS	1-Stubby Phillips screwdriver PH.2x25mmL
713 04B...08B	4-Slotted screwdriver 4mmx100mmL; 5.5mmx125mmL; 6.5mmx150mmL; 8mmx175mmL
713065BS	1-Stubby slotted screwdriver 6.5mmx25mmL



13pc wrench set

Part no.	Content:
754 0607...0810	2-Double open end wrench 6x7; 8x10 mm
755 08...17	7-Combination wrench 8; 10; 11; 12; 13; 14; 17 mm
758 1012...2427	4-45° Offset ring wrench 10x12; 14x17; 19x22; 24x27 mm

MOTORCYCLE

7. Torque wrench / Puller



Torque wrench
Page 7-1 ~ 7-9



**Torque handle fittings/
Torque driver**
Page 7-9 ~ 7-13



Torque multiplier
Page 7-15 ~ 7-16



**Puller tool (bearing /
gear separator)**
Page 7-17 ~ 7-34



■ **9pc Wheel specialized torque tool set**

64707



- Content: 1/2" DR.**
 6474 088N...190N 5- Torque wrench
 88; 108; 135; 163; 190 Nm
- 44585 17C...21C 3-Wheel nut 6pt. flank impact socket (85mmL)
 17; 19; 21 mm
- 681A300 1-Assembly wheel nut wrench
 17; 19; 13/16"; 1/2"DR. (300mmL)

1/12.4/13.4/0.85' 12.4kg

■ **3/8" DR. Preset torques wrench**

647...P



Part no.	Capacity Nm	l mm	 g
647318P	18	245	1500
647324P	24	245	1500

■ **11pc Torque wrench set**

64701L



- Content: 3/8" DR.**
 6473380 1- 3/8"DR. Lock torque wrench
- 535 10...21 6- 3/8"DR. 6pt. Flank socket
 10; 12; 14; 17; 19; 21mm
- 334050 04...08 4- 3/8"DR. Hex socket bit
 4; 5; 6; 8mm (50mmL)

12/20.4/21.4/0.85' 1.7kg

■ **11pc Torque wrench set**

64702L



- Content: 1/2" DR.**
 6474535 1- 1/2"DR. Lock torque wrench
- 545 17...27 6- 1/2"DR. 6pt. Flank socket
 17; 19; 21; 22; 24; 27 mm
- 344055 06...12 4- 1/2"DR. Hex socket bit
 6; 8; 10; 12 mm (55mmL)

6/18.1/19.1/1' 3016g

■ **Tone control torques wrench**

647



Part no.	Capacity Nm	 Packing	l mm	 g
6472270	1/4"DR. 5-25	20/15.4/16.4/1.19'	270	770
6473270 6473365	3/8"DR. 5-25 20-110	20/15.5/16.5/1.19' 20/21.5/22.5/1.46'	270 365	775 1075
6474470 6474630	1/2"DR. 42-210 70-350	12/19.8/20.8/1.1' 10/28.7/29.7/1.4'	470 630	1650 2870
6476850 64761030 64761215	3/4"DR. 65-450 140-700 140-980	4/18.1/19.1/1.7' 4/30.3/31.3/1.67' 2/16.2/17.2/1.13'	850 1030 1215	4525 7575 8100
64781215	1"DR. 140-980	2/16.3/17.3/1.13'	1215	8150
Part no.	Inch-lb	Packing	mm	g
6472270S	1/4"DR. 20-200	20/14.4/15.4/1.14'	270	720
6473270S	3/8"DR. 20-200	20/14.8/15.8/1.14'	270	740
Part no.	Ft-lb	Packing	mm	g
6473365S	3/8"DR. 5-80	20/21.0/22.0/1.14'	365	1050
6474470S 6474630S	1/2"DR. 10-150 25-250	12/20.2/21.2/1.1' 4/11.2/12.2/0.92'	470 630	1685 2800
6476850S 64761030S 64761215S	3/4"DR. 50-300 100-600 100-700	4/19.0/20.0/1.7' 4/30.0/31.0/1.67' 2/15.0/16.0/0.8'	850 1030 1215	4750 7500 7500
64781215S	1"DR. 100-700	2/15.0/16.0/0.8'	1215	7500

• Spare part available

PULLER/
TORQUE WRENCH

Lock torques wrench (tone control)

647



Unlock



Adjust



Lock



Part no.	Capacity Nm	Packing	l mm	g
6472295	1/4"DR. 6-30	20/19.0/20.0/1.12'	295	950
6473295	3/8"DR. 6-30	20/18.1/19.1/1.12'	295	905
6473380	20-110	12/13.7/14.7/1.57'	380	1140
6474380	1/2"DR. 20-110	12/15/16/1.3'	380	1250
6474535	40-210	10/21.0/22.0/1.31'	535	2100
6474660	70-350	6/17.9/18.9/0.92'	660	2980
6476880	3/4"DR. 100-500	4/18.7/19.7/1.07'	880	4675
64761095	140-700	4/31.0/32.0/1.93'	1095	7750
64761240	140-980	4/30.3/31.1/1.93'	1240	7575
64781240	1"DR. 140-980	2/16.2/17/1.13'	1240	8100
64781700	300-1500	1/12.0/13.0/0.9'	1700	11580

Part no.	Inch-lb	Packing	mm	g
6472295S	1/4"DR. 40-250	20/17.2/18.2/1.63'	295	860
6473295S	3/8"DR. 40-250	20/17.2/18.2/1.63'	295	860

Part no.	Ft-lb	Packing	mm	g
6473380S	3/8"DR. 15-80	8/9.1/10.1/0.76'	380	1140
6474535S	1/2"DR. 30-150	6/12.6/13.6/1.31'	535	2100
6474660S	50-250	6/17.7/18.7/0.92'	660	2950
6476880S	3/4"DR. 50-300	5/23.7/24.7/1.7'	880	4740
64761095S	100-600	4/30.0/31.0/1.8'	1095	7500
64761240S	100-700	2/16.0/17.0/1'	1240	8000
64781240S	1"DR. 100-700	2/16.0/17.0/1'	1240	8000
64781700S	200-1000	1/12.0/13.0/0.9'	1700	11580

• Spare part available

Lock torques wrench (tone control)

647



Unlock



Adjust



Lock



Part no.	Capacity Nm	Packing	l mm	g
6473383	3/8" DR. 15-80	12/12.5/13.1/0.76'	383	740
6473385	20-110	12/14.0/15.0/0.76'	383	960
6474536	1/2" DR. 40-210	10/20.6/21.2/1.3'	535	1070
6474645	70-350	6/18.4/19.0/0.92'	645	2540
6476865	3/4" DR. 100-500	4/19.5/20.5/1.1'	865	3660
64761088	140-700	4/30.0/31.0/1.9'	1088	5940
64761230	140-980	2/16.0/17.0/1.1'	1230	6460
64781230	1"DR. 140-980	2/16.0/17.0/1.1'	1230	6460

Part no.	Ft-lb	Packing	mm	g
6473383S	3/8" DR. 10-60	12/12.5/13.1/0.76'	383	740
6473385S	15-80	12/14.0/15.0/0.76'	383	960
6474536S	1/2" DR. 30-150	10/20.6/21.2/1.3'	535	1070
6474645S	50-250	6/18.4/19.0/0.92'	645	2540
6476865S	3/4" DR. 50-300	4/19.5/20.5/1.1'	865	3660
64761088S	100-600	4/30.0/31.0/1.9'	1088	5940
64761230S	100-700	2/16.0/17.0/1.1'	1230	6460
64781230S	1"DR. 100-700	2/16.0/17.0/1.1'	1230	6460

• Spare part available



Clock wise click
for right thread nut



Anti-clock wise click
for left thread nut

PULLER/
TORQUE WRENCH

Lock torque wrench - window display (tone control)

647...W

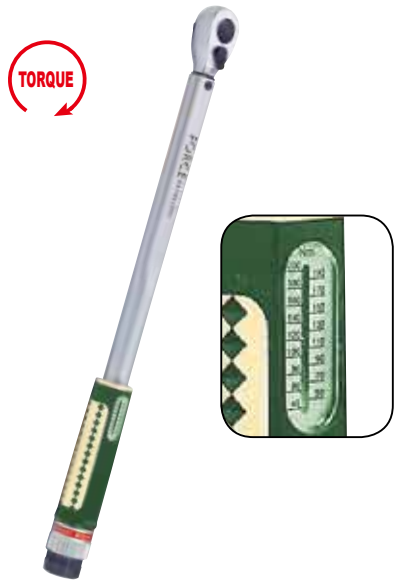

Part no.	Capacity	Packing	l mm	g
6472300W	1/4"DR. 6-30Nm 40-250in-lb	20/16.0/17.0/1.63'	300	800
6473420W	3/8"DR. 20-100Nm 15-75ft-lb	12/16.8/17.8/1.57'	420	1400
6474530W	1/2"DR. 40-200Nm 30-150ft-lb	10/16.0/17.0/1.31'	530	1600

• Spare part available

Lock torque wrench - window display

647...W



Part no.	Capacity Nm	l mm	g
6472290W	1/4" DR. 1-25	290	420
6473360W	3/8" DR. 5~50	360	920
6474405W	1/2" DR. 10-100	405	1020
6474500W	20-200	500	1200
6474595W	60-300	595	1330
6474680W	80-400	680	1820
6476970W	3/4" DR. 100-550	970	3700
64761150W	150-750	1150	5600
64781250W	1" DR. 200-1000	1250	7200

• Spare part available

Double click torque wrench

647A

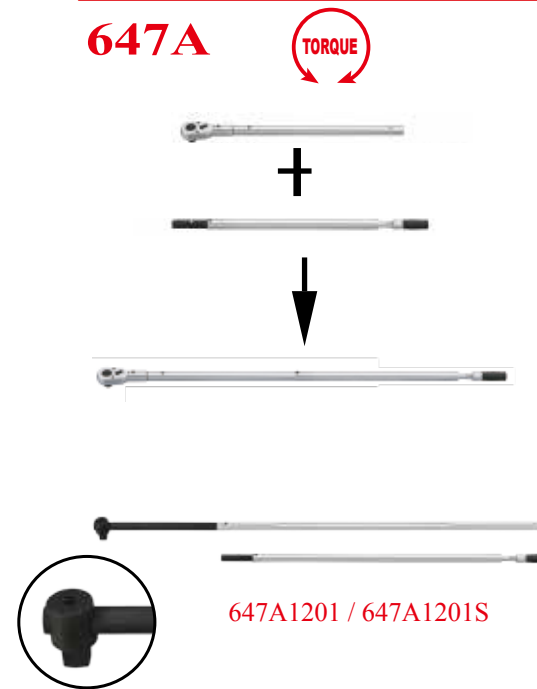

Part no.	Capacity	l mm	kg
647A602	3/4"DR. 300-1500Nm	1720	12
647A602S	200-1000Ft-lb	1720	12
647A802	1"DR. 300-1500Nm	1720	12
647A802S	200-1000Ft-lb	1720	12
647A803	1" DR. 400-2000Nm	2176	13
647A803S	300-1500Ft-1b	2176	13
647A1201	1-1/2"DR. 600-3000Nm	2780	15
647A1201S	400-2000Ft-1b	2780	15

• Spare part available

Lock torques wrench-window display (tone control)

6472195W



- **6472195W** : 1/4"DR. 3-15Nm (195mm)
- Nm in display only.

Interchangeable torque handle (Adjustable torque)

647B



Part no.	mm	Torque Nm	l mm	g
647B005D	9x12	1-5Nm	195	340
647B030D	9x12	6-30Nm	220	420
647B110D	9x12	20-110Nm	403	970
647B210D	14x18	40-210Nm	460	1160
647B350D	14x18	70-350Nm	525	1310
647B450D	14x18	75-450Nm	775	2220

Part no.	mm	Torque Nm	l mm	g
647B800D	20x28.5	100-800Nm	960	5750
647B1500D	20x28.5	300-1500Nm	1786	8200

■ 1/4"DR. torque driver

6472160



Part no.	Capacity	packing	g
	Nm		
64721602	0.4-2	100/18/18.8/1.02'	130
64721605	1-5	30/11.7/12.3/1'	280
64721608	2-8	30/13.21/13.81/1'	280
64721610	2-10	30/13.6/14/0.96'	452

■ 8pc Head-interchangeable torque wrench & spanner set

64709



- **647B210** :40~210Nm Torque wrench (14×18)
- Ø 43, 60, 72, 50, 63.2, 82, 32 mm

4/15.7/16.7/0.78' 3925g

■ 10pc Head-interchangeable torque wrench & spanner set

64710



- **647B030** :6~30 Nm Torque wrench
- **647H209** :1/4" DR. 9 X 12 Ratchet head
- 9 X 12 Spanner head: 7, 8, 9, 10, 11, 12, 13, 14mm

10/15.2/15.8/1.29' 1.52kg

■ 12pc Head-interchangeable torque wrench & spanner set

64711



- **647B110** :20~110 Nm Torque wrench
- **647H309** :3/8" DR. 9 X 12 Ratchet head
- 9 X 12 Spanner head: 10, 11, 12, 13, 14, 15, 16, 17, 18, 19mm
- **647A201** :1-1/2" DR. 600~3000Nm, L:2180, 15kg
- **647A201S** :1-1/2" DR. 400~2000Nm, L:2180, 15kg

10/21.6/22.4/1.68' 2.16kg

■ 11pc Head-interchangeable torque wrench & spanner set

64712



- **647B015** :3~15 Nm Torque wrench
- **647H209** :1/4" DR. 9 X 12 Ratchet head
- 9 X 12 Spanner head: 5.1mm, 5.8mm, 6.1mm, 6.3mm, 6.4mm, 6.5mm, 6.7mm, 6.9mm; 6 PT. Spline

30/23.0/24.0/0.74' 765g

■ 10pc Head-interchangeable torque wrench & spanner set

64713



- **647B030W** :6~30 Nm Torque wrench
- **647H309A** :3/8" DR. 9 X 12 Ratchet head
- 9 X 12 Spanner head: 7, 8, 9, 10, 11, 12, 13, 14mm

10/15.2/16.2/1.29' 1.52kg

■ 12pc Head-interchangeable torque wrench & spanner set

64714



- **647B060W** :10~60 Nm Torque wrench
- **647H409** :1/2" DR. 9 X 12 Ratchet head
- 9 X 12 Spanner head: 10, 11, 12, 13, 14, 15, 16, 17, 18, 19mm

10/18.1/18.7/1.68' 1.81kg

■ 12pc Head-interchangeable torque wrench & spanner set

64715



- **647B100W** :20~100 Nm Torque wrench
- **647H409** :1/2" DR. 9 X 12 Ratchet head
- 9 X 12 Spanner head: 10, 11, 12, 13, 14, 15, 16, 17, 18, 19mm

10/21.6/22.4/1.68' 2.16kg

PULLER/
TORQUE WRENCH

8pc Head-interchangeable torque wrench & spanner set

64704



- Contents:**
- 647B080 1- 15~80Nm Torque wrench(14mm x 18mm)
 - 647H414A 1- 1/2"DR. Ratchet head (24 teeth)
14mm x 18mm small, width 36mm
 - 68514 17...29 6- Spanner head (14mm x 18mm)
17; 22; 24; 26; 27; 29 mm
- 6/19.5/20.5/1.2' 3250g

11pc Head-interchangeable torque wrench & spanner set

64705



- Contents:**
- 647B210 1- 40~210Nm Torque wrench(14mm x 18mm)
 - 647H414 1- 1/2"DR. Ratchet head (24 teeth)(14mm x 18mm)
 - 68514 13...30 9- Spanner head (14mm x 18mm)
13; 14; 15; 17; 19; 22; 24; 27; 30 mm
- 4/17.7/18.7/0.96' 4425g

Torque handle fittings

647H

24 Teeth Ratchet head (9 X 12 mm)



Part No.	DR.
647H209	1/4"
647H309	3/8"
647H309A	3/8" (small, width 27mm)
647H409	1/2"

647H...-72

72 Teeth round ratchet head (9 X 12 mm)



Part No.	DR.
647H209-72	1/4"
647H309-72	3/8"
647H409-72	1/2"

Torque handle fittings

68509

Open end wrench head (9x 12mm)



Part No.	Size (mm)
6850907	7
6850908	8
6850909	9
6850910	10
6850911	11
6850912	12
6850913	13
6850914	14
6850915	15
6850916	16
6850917	17
6850918	18
6850919	19

685A09

Box end wrench head (9 X 12 mm)



Part No.	Size (mm)
685A0907	7
685A0908	8
685A0910	10
685A0911	11
685A0912	12
685A0913	13
685A0914	14
685A0915	15
685A0916	16
685A0917	17
685A0918	18
685A0919	19
685A0921	21
685A0922	22

685B09

Flare nut wrench head (9 X 12 mm)



Part No.	Size (mm)
685B0910	10
685B0911	11
685B0912	12
685B0913	13
685B0914	14
685B0916	16
685B0917	17
685B0918	18
685B0919	19
685B0921	21
685B0922	22

Torque handle fittings

647H

24 Teeth Ratchet head (14 X 18 mm)



Part No.	DR.
647H314	3/8"
647H414	1/2"
647H414A	1/2" (small, width 36 mm)

647H...-72

72 Teeth round ratchet head (14 X 18 mm)



Part No.	DR.
647H414-72	1/2"
647H314-72	3/8"

68514

Open end wrench head (14 X 18 mm)



Part No.	Size (mm)	Part No.	Size (mm)
6851413	13	6851429	29
6851414	14	6851430	30
6851415	15	6851432	32
6851416	16	6851434	34
6851417	17	6851436	36
6851418	18	6851438	38
6851419	19	6851440	40
6851421	21	6851441	41
6851422	22	6851442	42
6851424	24	6851444	44
6851426	26	6851446	46
6851427	27		

Torque handle fittings

685A14

Box end wrench head (14 X 18 mm)



Part No.	Size (mm)	Part No.	Size (mm)
685A1413	13	685A1427	27
685A1414	14	685A1429	29
685A1415	15	685A1430	30
685A1416	16	685A1432	32
685A1417	17	685A1434	34
685A1418	18	685A1436	36
685A1419	19	685A1438	38
685A1421	21	685A1440	40
685A1422	22	685A1441	41
685A1424	24	685A1442	42
685A1426	26	685A1444	44
		685A1446	46

685C14

Single hook spanner head (14 X 18 mm)



Part No.	Size (mm)
685C1443	43±5mm
685C1460	60±5mm
685C1472	72±5mm
685C1450	50±5mm
685C1463	63.2±5mm
685C1482	82±5mm
685C1432	32±5mm (strong type)

685D14

Double hook spanner head (14 X 18 mm)



Part No.	Size (mm)
685D1432	31.6±5mm
685D1435	34.9±5mm
685D1442	41.9±5mm
685D1450	50±5mm
685D1463	62.9±5mm

■ **Open end wrench head (20 x 28.5 mm)**

68520



Part No.	Size (mm)
6852032 <small>NEW</small>	32
6852036 <small>NEW</small>	36
6852041 <small>NEW</small>	41
6852046 <small>NEW</small>	46
6852050	50
6852055	55
6852060	60
6852065	65

■ **Box end wrench head (20 x 28.5 mm)**

685A20



Part No.	Size (mm)
685A2050	50
685A2055	55
685A2060	60
685A2065	65

■ **2pc Torque driver set**

64703 / 64703A



Content: 1/4" DR.

- 64721605 1- 1/4"DR. Torque driver (1-5Nm)
- 81022 1- Bit holder 1/4"(F)x1/4" inhex

64703A Changed item

- 64721608 1-Torque driver (2-8Nm)

40/15.7/16.7/0.5' 393g

■ **47pc Torque driver set**

K64706 / K64706S

Content: 1/4"DR.



- 64721605 1- Torque driver (1~5Nm)
- 81022 1- Bit holder 1/4"(F)x1/4" inhex
- 8042100 1- Extension 4"
- 12125 0...3 4- Phillips bit (25mmL) PH.0; PH.1; PH.2; PH.3
- 12223 0...3 4- Pozidriv bit (25mmL) PZ.0; PZ.1; PZ.2; PZ.3
- 12325 03...065 5- Slotted bit 3; 4; 5; 5.5; 6.5 mm
- 12425 015...06 6- Hex bit 1.5; 2; 3; 4; 5; 6 mm
- 124R25 1...3 3- Square bit 1; 2; 3 mm
- 12625 06...40 11- Star bit T6; T7; T8; T9; T10; T15; T20; T25; T27; T30; T40
- 12725 06...40 11- Star tamperproof bit T-6H; T-7H; T-8H; T-9H; T-10H; T-15H; T-20H; T-25H; T-27H; T-30H; T-40H

K64706S Changed item

- 64721605S 1- Torque driver (10~50 Inch-lb)

24/21.7/22.7/1.5' 905g

■ **49 pc Torque driver set**

K64708

Contents: 1/4"DR.



- 64721605 1-Torque driver 1/4" inhex (1~5Nm)
- 8092225 1-Bit adaptor 1/4" Hex-1/4" Sq
- 81260 1-Magnetic inhex extension 60mmL
- 12125 0...3 4- Philips bit (25mmL) PH.0; PH.1; PH.2; PH.3
- 12225 0...3 4-Pozidriv bit (25mmL) PZ.0; PZ.1; PZ.2; PZ.3
- 12225 03...065 5-Slotted bit 3; 4; 5.5; 6.5 mm
- 12425 015...06 6-Hex bit 1.5; 2; 3; 4; 5; 6 mm
- 124R25 1...3 3-Square bit 1; 2; 3 mm
- 12625 04...40 13-Star bit T4; T5; T6; T7; T8; T9; T10; T15; T20; T25; T27; T30; T40
- 12725 06...40 13-Star tamperproof bit T-6H; T-7H; T-8H; T-9H; T-10H; T-15H; T-20H; T-25H; T-27H; T-30H; T-40H

24/16.4/17.4/1.5' 684g

Torque multiplier set

65111L



- Contents:**
- 65111 2-Torque multiplier head & 380mm reaction bar
1/2"(F)x3/4"(M) Max Output 1500 Nm
 - 65111L-1 1-90° Reaction bar
 - 65111L-2 1-90° Reaction Base
 - 65111L-3 2-Break-Away adapter

- Always apply the break-away adapter in order to protect the torque multiplier from damage.
- The break-away adapter is expendable.

3/10.5/11.5/1.2' 3500g

Torque multiplier set

65112L



- Contents:**
- 65112 2-Torque multiplier head & 380mm reaction bar
1/2"(F)x1"(M) Max Output 2000 Nm
 - 65112L-1 1-90° Reaction bar
 - 65112L-2 1-90° Reaction Base
 - 65112L-3 2-Break-Away adapter

- Always apply the break-away adapter in order to protect the torque multiplier from damage.
- The break-away adapter is expendable.

3/10.5/11.5/1.2' 3500g

Torque multiplier set

65113L



- Contents:**
- 65113 2-Torque multiplier head & 380mm reaction bar
3/4"(F)x1"(M) Max Output 2500 Nm
 - 65113L-1 1-90° Reaction bar
 - 65113L-2 1-90° Reaction Base
 - 65113L-3 2-Break Away adapter

3/10.5/11.5/1.2' 3500g

Mechanical torque multipliers

651



	Max. Output	Square Drive	Ratio
Part no.	Nm / Ft-lb	size	
65101	1500/1100	1/2" to 3/4"	1:3
65102	3000/2200	3/4" to 1"	1:3
	Max. Input		
Part no.	Nm / Ft-lb	Packing	g
65101	500/365	4/14.4/15.4/0.75'	3600
65102	1000/730	4/19.4/20.4/1'	4850

- Spare part available
- Impact use is prohibited
- **65101L / 65102L**: Supplied with the reaction bar styles for maximum versatility.

Torque multiplier

65103 / 65104



Part no.	Drive	Ratio	Max Input	Max Output	
			Nm / Ft-lb	Nm / Ft-lb	g
65103	1/2"(F)x3/4"(M)	1:10	150/110	1500/1100	3400
65104	1/2"(F)x1-1/2"(M)	1:10	400/290	4000/2900	16000

- Impact use is prohibited

Mechanical Torque Multipliers

651



Part no.	Drive	Torque Ratio	Max. input	Max. output	
65106	1/2"(F)x3/4"(M)	1:5	260Nm	1300Nm	8.8kg
65107	3/4"(F)x1"(M)	1:5	540Nm	2700Nm	8.7kg

- *Material: SCM440 (4140)
- *Finish: Manganese phosphate

Open ended pre-set torque wrench

647C



Part no.	Spanner size	Torque	<i>l</i>	
	mm	Nm	mm	g
647C1817	17	18	220	410
647C4222	22	42	230	450
647C5526	26	55	290	600
647C6529	29	65	295	620

Pipe torque wrench

647P



Part no.	Torque	<i>l</i>	
	Nm	mm	kg
647P210	40-210	590	3
647P350	70-350	825	3.7
647P500	100-500	920	4.3

*Accuracy: +6%

Hydraulic bearing separator puller set

66601

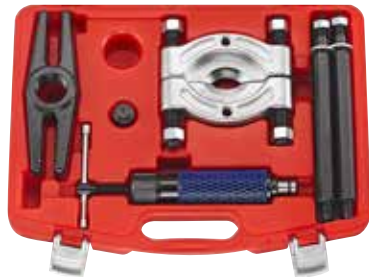

Contents:

- 1pc Hydraulic ram (SCM415 Diameter 37.7mm x 160mmL x 16t)
- 1set Bearing separator & bolts, SCM415, capacity 75-105mm
- 2pc Main rod (8"x1.75p)
- 2pc Extension rod (8"x1.75p)
- 1pc Beam

2/15.2/16.2/0.53' 7.6kg

Pressure screw separator puller set

66602



Contents:

- 1pc Central bolt
- 1set Bearing separator & bolts, SCM415, capacity 75-105mm
- 2pc Main rod (8"x1.75p)
- 2pc Extension rod (8"x1.75p)
- 1pc Beam
- 1pc Nut

2/17.3/18.3/1' 8650g

Two sets bearing separator kit

66610



- 2 sets Bearing separator & bolts (SCM415 Drop forged HRC 42-45)
Capacity: 30-50mm
Capacity: 50-75mm
- 4pc Main/Extension rod (Hex bar 17mm x 127mmL x 3/8" - 16T)
- 4pc Main/Extension rod (Hex bar 14mm x 102mmL x 3/8" - 16T)
- 1pc Beam (S45C)
- 1pc Forcing screw (Φ9/16" - 10T/inch x 175mmL S45C)
- Packing: Blow mold case



5/23.0/24.0/1.8' 4.6kg

Pressure screw separator puller set

66612



- 1 set Bearing separator & bolts (SCM415 Drop forged HRC 42-45) Capacity: 75-105mm
- 2pc Main rod (Hex bar 19mm x 8"L x Φ15.24mm - 1.75P)
- 2pc Extension rod (Hex bar 19mm x 8"L x Φ15.24mm - 1.75P)
- 1pc Beam (S45C)
- 1pc Forcing screw (Φ18.65 - 10T/inch x 292mmL S45C)
- 1pc Central nut
- Packing: Metal case



2/18.0/19.0/0.5' 9kg

Hydraulic bearing separator puller set

66613



- 1pc Hydraulic ram (SCM420 Φ37.7mm)
- 1 set Bearing separator & bolts (SCM415 Drop forged HRC 42-45)
Capacity: 105-150mm
- 2pc Main rod (Hex bar 21mm x 10"L x Φ5/8" - 11 NC)
- 2pc Extension rod (Hex bar 21mm x 10"L x Φ5/8" - 11 NC)
- 1pc Beam (Ductile)
- 1pc Adaptor (Carbon steel)
- Packing: Metal case



2/24.0/25.0/0.8' 12kg

Mini bearing separator assembly

66614



Bearing separator inside:

- Capacity 3/8" - 1 1/4" (10mm to 30mm)
- Bolt (6.3mm x 83mmL x 1/4" x 20UNC)
- Body thread 3/8" x 20UNC



Pull out the bearing with the H-type beam and bolts.

20/12.7/13.7/0.8' 636g

Hydraulic bearing separator puller set

666

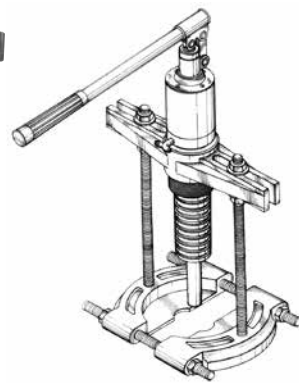

Part no.	Capacity	Reach(mm)	Spread(mm)	Stroke	kg
66605	6 tons	300/190	235/90	82	16
66606	8 tons	300/245	235/90	82	17
66607	10 tons	300/190	235/90	82	16
66608	12 tons	300/245	235/90	82	17

Bearing separator

666



Item No.	Capacity	Bolt	Hole
666050	1-1/4" to 2-1/4" (30-50mm)	9.5mm x 125mmL x 3/8" x 24t	8.2mm x 3/8" x 16t
666075	2-1/4" to 3-1/2" (50-70mm)	12.7m m x 135mmL x 1/2" x 20t	8.2mm x 3/8" x 16t
666105	3" to 4-1/2" (75-105m)	16m m x 165 mm L x 5/8" x 18t	11.2m m x 1/2" x 12t
666150	4" to 6" (105-150mm)	19m m x 260 mm L x 3/4" x 16t	14.6mm x 5/8" x 11t
666225	35-225	20m m x 255 mm L	5/8" x 11P
666300	35-300	26m m x 355 mm L	3/4" x 10P

Bearing Separator

666140



- Capacity 1.5" to 6" (35-140mm)

4/30.0/31.0/1' 7.5Kg

K3 Series

666T

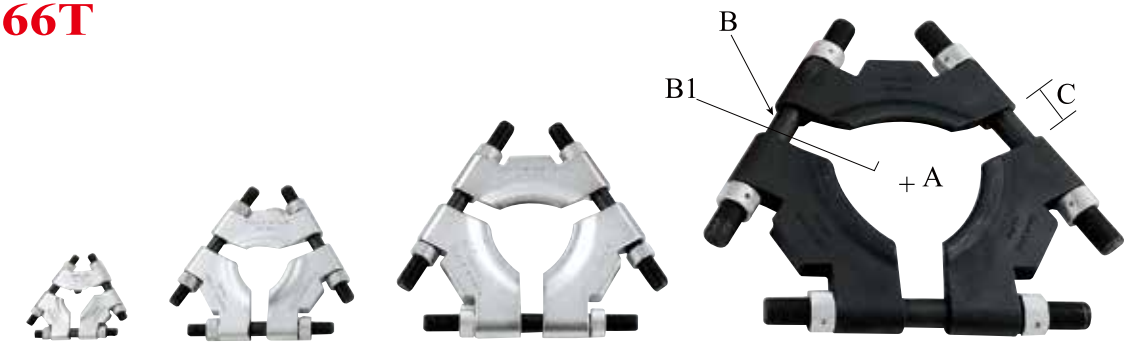

Item No.	A	B	B1	C	Weight (kg)
666T050	50	90	70	32	0.43
666T100	100	172	139	64	2.27
666T160	160	250	205	95	6.07
666T260	260	400	335	146	19.40
666T380	380	542	457	206	48.21

Locking jaw puller set

664P



With several pulling attachments to give the user various methods for pulling, maintenance and repair applications.

Contents:

- 9pc Adjustable reversible jaw
- 1pc Forcing screw
- 1pc Two-way yoke
- 1pc Three-way yoke
- 1pc Reversible adjusting nut
- 3pc Screw & nut

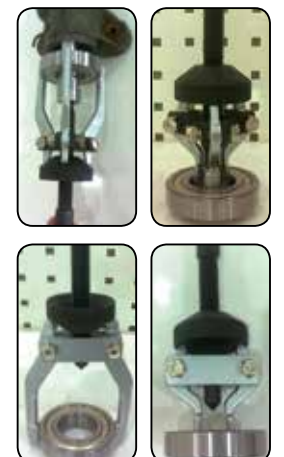

6/13.6/14.6/1.33' 2260g

Internal & external puller set

66431



- Drop forged chrome vanadium steel

Contents:

- 1-Internal small (Capacity: 15-30mm)
- 1-Internal large (Capacity: 30-80mm)
- 1-External (Capacity: 15-80mm)

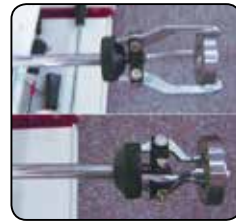

3/16.0/17.0/1.5' 5300g

Rear Axle puller & external rearing puller set

66432



- Chrome molybdenum steel external bearing puller with chrome plated & black finish.
- Suitable for rear axle puller & external bearing puller.

Contents:

- 1-Slide screw: 5/8" – 16T X 22-1/2" (16mm – 16T X 57cm)
- 1-External bearing puller capacity from 15-80mm (9/16" – 3-1/2")
- 1-Axle yoke
- 1-Bearing adaptor
- 1-Slide hammer 3-3/4 LB (1.75kg)
- 1-Lock nut 5/8" (16mm)
- 1-Bearing hook

3/16.0/17.0/1.5' 5300g

Blind hole bearing puller set

905T6



- One slide hammer shaft & 4 clamps.
 - Adjustable collets make easy removal of bearing or bushings from blind holes.
- Clamps: 1/2" (10-14mm), 5/8" (15-19mm), 13/16" (20-24mm), 1-1/8" (25-32mm)



5/17.5/18.5/1.25' 3650g

Blind hole bearing puller

910T1



- Two function bearing remover for puller and slide hammer.
- One slide hammer, 62mm tailpipe expanders and pullers for 8mm~32mm.



5/16.5/17.5/1.66' 3500g

2-in-1 Bearing Puller (2 Jaws)

66621

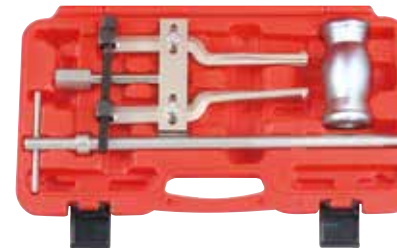

- Inside diameter 38mm ~ 120mm

2/10.7/11.7/0.62' 5400g

2-in-1 Bearing Puller (3 Jaws)

66620



- Inside diameter 12mm ~ 38mm

4/12.4/13.4/1.17' 3050g



■ Pilot bearing puller

66619



- Capacity: inside diameter 12mm-38mm, 1/2"~1-1/2"

20/18.3/19/0.8' 920g

■ Thick jaws gear puller

65910



- Jaws thickness: 1.5 mm
- Depth : 100mm
- Bearing dimension: 40-90mm



20/15.0/16.0/1.1' 680g

■ Bearing puller

666A



Part no.	Capacity mm	 g	 packing
666A035	19 - 35	280	40/11.2/12.2/1'
666A055	24 - 55	783	24/18.8/19.8/1.4'
666A080	35 - 80	600	20/12.0/13.0/1'



■ Long jaw bearing puller

66616



- For long distance pulling jobs
- Capacity 10-50mm
- Alloy steel
- Jaw long 300mm (SCM415 drop forged HRC 40-42)
- Drop forged hardened 48°-50°
- Forcing screw (SCM415)
- Stopper cone (S45C)
- Connector (SCM415)

24/26.0/27.0/2.6' 1200g

■ Bearing separator

66618



- This kit is different from other bearing separators. When obstruction is round external dia. and internal dia. of bearing, it can be used on the confined space to damage the protecting cover of bearing and easily remove bearings.
- Adjust range: 20 ~ 95 mm
- Bearing range:
6004 ~ 6010 (Jaw size: Ø 6 / 8)
6201 ~ 6206 (Jaw size: Ø 5.5 / 6 / 8) ;
6300 ~ 6304 (Jaw size: Ø 6 / 8)



20/17.0/18.0/1.5' 800g

■ Bearing separator

66618M



- This kit is different from other bearing separators. When obstruction is round external dia. and internal dia. of bearing, it can be used on the confined space to damage the protecting cover of bearing and easily remove bearings.
- Adjust range: 35 ~ 120 mm
- Bearing range:
6207 ~ 6211 (Jaw size: Ø 11 / 12.5 / 15)
6305 ~ 6308 (Jaw size: Ø 11 / 12.5) ;
6403 ~ 6405 (Jaw size: Ø 11 / 12.5 / 15)

12/22.0/23.0/1.3' 1700g

■ Unique bearing removal kit

66618MA



- Three-way operation allows use with traditional bearing separator, internal or external legs or bearing race separator. Bearing race separator application makes this kit ideal for use on "blind" mounted bearings where rear of bearing is not accessible.
- Adjust range: 35 ~ 120 mm
- Bearing range: 6207 ~ 6211 (Jaw size: Ø 11 / 12.5 / 15)
6305 ~ 6308 (Jaw size: Ø 11 / 12.5) ;
6403 ~ 6405 (Jaw size: Ø 11 / 12.5 / 15)
- Beam : 30~50 mm
- Legs: 30~90 mm

5/17.0/18.0/1.2' 2700g

■ Differential side bearing puller

666A01



- Used to removing differential side carrier bearing. Works on a wide variety of cars and light-duty trucks.
- Includes four step plate adapters to fit carrier bearings.

10/22.5/23.5/1.46' 2250g

■ A/C Clutch puller set

666A02



- Versatile 2-jaw puller designed to remove stubborn A/C clutch pulleys.
- Features two sets of jaws, a crossbar with three settings for correct spread, and an adjustable yoke to keep jaws tight.
- Spread of jaws: 3" to 5". Reach of jaws: 1" to 2-1/4".

10/22.0/23.0/1.46' 2200g

■ 21pc Go-through ratchet socket set (SAE&MM)

666A03



- For a wide range of pulling jobs, including: bearings, alternators, generators, power steering and crankshaft pulleys, timing gears, and harmonic balancers.
- Spread: 2-3/8" to 3-3/8" & 3-1/2" to 5-1/2"
- Reach: 1-5/8" & 1-3/4"
- Set includes drop-forged components, which can be used in a variety of combinations.

5/20.6/21.6/1.3' 4120g

■ Hydraulic gear puller set

66622



- For agriculture/ Machine/ Garage/ Industry use
- Hydraulic ram (SCM420 Ø37.7mm)
 - Twin Head 1pc
 - Triple head 1pc
 - Ram nut (SCM415 HRC 42-45)
 - Beam (S45C)
 - 4" Leg 3 pcs (SCM415 HRC 42-45)
 - 6" Leg 3 pcs (SCM415 HRC 42-45)
 - 8" Leg 3 pcs (SCM415 HRC 42-45)
 - Sent pop (Ø1" × L30mm S45C)
 - Ram extension rod (Ø1" × L2" S45C)
 - Ram extension rod (Ø1" × L2" S45C)
 - Main rod 2 pc (Hex bar 19mm × L8" × Ø15.24mm-1.75P)
 - Extension rod 2pc (Hex bar 19mm × L8" × Ø15.24mm-1.75P)
 - Bearing separator Spread range 75-150mm (SCM415 Drop forged HRC 42-45)

1/16.5/17.5/1.2' 16.5kg

■ 6 ways multi purpose hydraulic gear puller

66623



- Hydraulic ram (SCM420 Ø 37.7mm)
- Combination cross head (S45C)
- Combination leg 3pcs (SCM415 Drop forged HRC 42-45)
- Steel Plate 6 pcs
- Screw/ Nut /Washer 6pcs
- Sent pop (Ø 1" × L30mm S45C)
- Ram Extension rod (Ø1"× L2" S45C)

5/24.0/25.0/1.3' 4800g

■ Micro 3" jaw lock puller

66617



- Forcing screw (SCM415)
- Chuck (SCM415)
- 3" Jaw 3pieces (SCM415)

12/12.0/13.0/0.7' 1420g

Hydraulic 6" jaw lock puller

66617A



- Hydraulic ram (SCM420)
- Chuck (SCM415)
- 6" Jaw 3pieces (SCM415)

4/14.0/15.0/0.7'

5500g

Universal puller set

66627



- 1 beam 2-arm
- 1 beam 3-arm
- 9 pulling legs, length 150 / 220 / 300 mm
- 1 spindle

2/25.0/26.0/1.25'

12.4kg

Inside puller

66624



- Spread: 23-130 mm
- Depth: 140 mm

12/19.0/20.0/2'

1600g

2&3 Jaws gear puller set

66628



- 1 beam with 2-arm and 3-arm
- 6 pulling legs, length 130 / 200 mm
- 1 spindle (219mm)

6/16.5/17.5/0.93'

12.4kg

Outside puller

66625



- Spread: 7-140 mm
- Depth: 147 mm

12/22.0/23.0/1.6'

1.8kg

Separate hydraulic puller

6590825



Part no.	Capacity	Reach(mm)	Spread(mm)	Stroke(mm)	kg
6590825	25 tons	375-15"	540	110	30

Universal puller set

66626



- 1 beam 2-arm
- 1 beam 3-arm
- 9 pulling legs, length 100 / 200 / 250 mm
- 2 spindle

3/20.5/21.3/1.2'

7200g

Hydraulic puller with hydraulic pump

6590850



Part no.	Capacity	Reach(mm)	Spread(mm)	Stroke(mm)	kg
6590850	50 tons	405-16"	800	250	45
6590850L	50 tons	635-25"	1200	250	49

Hydraulic puller

65911



Part no.	Capacity	Reach(mm)	Spread(mm)	Stroke(mm)	kg
6591106	6 tons	300-12"	95/235	82	6
6591108	8 tons	300-12"	95/235	82	7
6591110	10 tons	330-13"	95/235	82	6
6591112	12 tons	330-13"	95/235	82	7

Hydraulic puller

65912



Part no.	Capacity	Reach(mm)	Spread(mm)	Stroke(mm)	kg
6591206	6 tons	170-7"	95/210	82	6.5
6591208	8 tons	220-9"	95/220	82	7.5
6591210	10 tons	190-8"	95/210	82	6.5
6591212	12 tons	240-10"	95/220	82	7.5

Hydraulic puller

65913



Part no.	Capacity	Reach(mm)	Spread(mm)	Stroke(mm)	kg
6591306	6 tons	170-7"	95/210	82	8.5
6591308	8 tons	220-9"	95/220	82	9.5
6591310	10 tons	190-8"	95/210	82	8.5
6591312	12 tons	240-10"	95/220	82	9.5

Hydraulic puller

65906



Part no.	Capacity	Reach(mm)	Spread(mm)	Stroke(mm)	kg
6590604	4 tons	152-6"	150	55	4.5
6590606	6 tons	152-6"	200	82	4.9
6590606L	6 tons	190-8"	200	82	4.9
6590608	8 tons	190-8"	250	82	6.6
6590608L	8 tons	225-10"	250	82	6.6
6590615	15 tons	225-10"	280	82	8.0
6590615L	15 tons	300-12"	280	82	8.0

Hydraulic puller

6590630



Part no.	Capacity	Reach(mm)	Spread(mm)	Stroke(mm)	kg
6590630	30 tons	375-15"	540	110	31

Hydraulic puller

65907



Part no.	Capacity	Reach(mm)	Spread(mm)	Stroke(mm)	kg
6590710	10 tons	182-7"	280	82	5.6
6590710L	10 tons	220-9"	280	82	5.6
6590712	12 tons	220-9"	305	82	7.6
6590712L	12 tons	260-10"	305	82	7.6
6590720	20 tons	260-10"	356	82	10
6590720L	20 tons	300-12"	356	82	10

Hydraulic puller

6590725



Part no.	Capacity	Reach(mm)	Spread(mm)	Stroke(mm)	kg
6590725	25 tons	300-12"	406	110	20
6590725L	25 tons	375-15"	406	110	20

Separate hydraulic puller

65908



Part no.	Capacity	Reach(mm)	Spread(mm)	Stroke(mm)	kg
6590815	15 tons	230-9"	280	82	14
6590815L	15 tons	300-12"	280	82	14

■ Puller accessory

659C2



Part no.	Capacity	Reach(mm)	Spread(mm)	Stroke(mm)	kg
659C208	8-12 tons	220-9"	95/220	82	6.0
659C210	6-10 tons	190-8"	95/210	82	5.0

■ Puller accessory

659C3



Part no.	Capacity	Reach(mm)	Spread(mm)	Stroke(mm)	kg
659C308	8-12 tons	220-9"	95/220	82	9.0
659C310	6-10 tons	190-8"	95/210	82	8.0

■ Puller accessory and straightener

659A



Part no.	Reach(mm)	Spread(mm)	Stroke(mm)	kg
659A01	150	100/410	82	9.5
659A02	205	100/410	82	9.0
659A03	205/150	100/410	82	10.0

• This puller part converts 6590615 and 6590815 into a hydraulic straightening tool

■ Gear puller - 2 Jaw

65901



Part no.	size	Capacity	Spread(mm)
6590103	3"	2 tons	40/75
6590104	4"	4 tons	50/100
6590106	6"	6 tons	70/150
6590108	8"	10 tons	95/200
6590112	12"	15 tons	140/300



■ Gear puller - 3 Jaw

65902



Part no.	size	Capacity	Spread(mm)
6590203	3"	3 tons	40/75
6590204	4"	6 tons	50/100
6590206	6"	9 tons	70/150
6590208	8"	15 tons	95/200
6590212	12"	22 tons	140/300



■ Gear puller - 2 Arm

65903



Part no.	Jaw open mm	Capacity ton	kg
65903065	25-65	1.5	0.4
65903090	30-90	3.0	0.9
65903130	45-130	3.0	1.0
65903160	45-160	4.0	2.8
65903210	45-210	4.0	3.0
65903270	65-270	5.0	7.5
65903340	65-340	5.0	8.2

■ Gear puller - 2 Jaw

65909



Part no.	Size	Length	Ton	kg
65909090	90	100	3	1.1
65909130	130	100	3	1.3
65909160	160	150	5	3.2
65909200	200	150	5	3.6
65909250	250	200	7.5	7.8
65909350	350	200	7.5	9.2
65909520	520	200	10	15.2
65909640	640	225	15	23.2



Quick-adjusting puller - 2 Arm

65909Q



Part no.	Jaw open	Reach	Packing	kg
	mm	mm		
65909090Q	90	100	12/14.0/15.0/0.57'	1.2
65909130Q	130	100	12/15.5/16.8/0.57'	1.3
65909160Q	160	150	6/18.6/19.6/0.56'	3.1
65909200Q	200	150	6/21.3/22.3/0.63'	3.6
65909250Q	250	200	3/21.8/22.8/0.62'	7.3

Gear puller – 3 Arm

65910



Part no.	Jaw open	Reach	Packing	kg
	mm	mm		
65910090	90	100	12/17.8/18.8/0.71'	1.5
65910130	130	100	12/19.8/20.8/0.79'	1.7
65910160	160	150	3/12.2/13.2/0.46'	4.1
65910200	200	150	3/13.2/14.2/0.54'	4.4
65910250	250	200	2/18.1/19.1/0.82'	9.1

Quick-adjusting puller - 3 Arm

65910Q



Part no.	Jaw open	Reach	Packing	kg
	mm	mm		
65910090Q	90	100	12/18.3/19.3/0.71'	1.5
65910130Q	130	100	12/20.1/21.1/0.79'	1.7
65910160Q	160	150	3/12.3/13.3/0.46'	4.1
65910200Q	200	150	3/13.3/14.3/0.54'	4.4
65910250Q	250	200	2/17.6/18.6/0.82'	8.8

Mechanical

65903



6590312 6590309 6590305

Item No.	Span (mm)	Depth (mm)	Dimensions (mm)	Spindle Thread	Extraction force	Mass (Kg)
6590305	130(5")	105	(a)14+1(b)15+1	M14x1.5	45	1.9
6590309	230(9")	150	(a)19+1(b)22+1	M22x2.0	100	4.0
6590312	295(12")	235	(a)19+1(b)22+1	M22x2.0	100	5.1

8. General



**Socket bit tool /
Socket series**
Page 8-1 ~ 8-10



**Damaged bolt remove /
Screw extractor**
Page 8-22 ~8-26



Vise
Page 8-36~ 8-38



**Steel wire rope / Bolt
cutter**
Page 8-52 ~ 8-52



**Steel creeper / Steel
car seat**
Page 8-61 ~ 8-61



**Wrench series /
Screwdriver**
Page 8-11 ~ 8-17



**Threaded repair /
Nut cracker tool**
Page 8-26 ~8-28



Shears / Pliers
Page 8-38 ~ 8-44



**Inspection mirror /
Work light**
Page 8-53 ~ 8-57



Oil pump
Page 8-62 ~ 8-62



**Air hose reel / Air
blow gun**
Page 8-18 ~ 8-19



**Hammer / Chisel /
Pin punch**
Page 8-28 ~ 8-33



Pipe wrench
Page 8-45 ~ 8-46



**Magnetic pick-up /
Fender cover / Car seat**
Page 8-57 ~8-59



**Grease gun / Oil can
/ Pry bar**
Page 8-63 ~ 8-68



Stud extractor
Page 8-20 ~ 8-21



Riveter tool
Page 8-34 ~ 8-36



**Tubing cutter /
Double flaring tool**
Page 8-46 ~ 8-52



**Fender cover / Seat
cover**
Page 8-59 ~ 8-60



Brush
Page 8-69 ~ 8-69



20pc 1/2" Hex socket bit set

4206



Part no.	Content...
344055 05...12	7-Hex socket bit (55mmL) 5; 6; 7; 8; 9; 10; 12 mm
34406514	1-Hex socket bit (65mmL) 14 mm
344070 17...19	2-Hex socket bit (70mmL) 17; 19 mm
344100 05...14	9-Hex socket bit (100mmL) 5; 6; 7; 8; 10; 11; 12; 13; 14 mm
34411017	1-Hex socket bit (110mmL) 17mm
4/13/14/1.3'	3250g

26pc 1/2" Star socket bit set

4263



Part no.	Content...
346055 20...70	12-Star socket bit (55mmL) T20; T25; T27; T30; T35; T40; T45; T47; T50; T55; T60; T70.
346100 20...100	13-Star socket bit (100mmL) T20; T25; T27; T30; T40; T45; T50; T55; T60; T70; T80; T90; T100.
34614060	1-Star socket bit (140mmL) T60.
4/14.9/15.9/1.3'	3725g

28pc 1/2" Spline socket bit set

4285



Part no.	Content...
348055 05...16	8-Spline socket bit (55mmL) M5; M6; M8; M9; M10; M12; M14; M16.
348100 05...18	10-Spline socket bit (100mmL) M5; M6; M8; M9; M9.5; M10; M12; M14; M16; M18.
348140 08...14	5-Spline socket bit (140mmL) M8; M9; M10; M12; M14.
348055 14T...16T	2-Spline security socket bit (55mmL) M14; M16.
34810016T	1-Spline security socket bit (100mmL) M16.
674	2-M10 Alternator tools 1pc 1/2"DR. Spline(XZN) socket bit M10x110mmL 1pc Reaction corkscrew cap 33 teeth- Ø19mm-17mm hex

4/17.6/18.6/1.3' 4400g

26pc 1/2" Ribe socket bit set

4265



Part no.	Content...
349100 05...16	10-Ribe socket bit (100mmL) M5; M6; M7; M8; M9; M10; M12; M13;M14; M16.
349140 08...14	5-Ribe socket bit (140mmL) M8; M9; M10; M12; M14.
34914010V	1-Ribe socket bit (140mmL) M10V.
349063 05T...16T	9-Ribe tamperproof socket bit (63mmL) M5; M6; M7; M8; M9; M10; M12; M14;M16.
34905506	1-Ribe socket bit (55mmL) M6.

4/15.7/16.7/1.3' 3925g

26pc Special socket bit set

4266



Part no.	Content...
344100 11...13	2-Hex socket bit (100mmL) 11; 13.
34414010	1-Hex socket bit (140mmL) 10mm.
346100 60...70	2-Star socket bit (100mmL) T60; T70.
34614060	1-Star socket bit (140mmL) T60.
34710055	1-Star tamperproof socket bit (100mmL) T-55H
34710570	1-Star tamperproof socket bit (105mmL) T-70H.
34713030	1-Star tamperproof socket bit (130mmL) T-30H.
34714080	1-Star tamperproof socket bit (140mmL) T-80H.
34810014	1-Spline socket bit (100mmL) M14.
34812009	1-Spline socket bit (120mmL) M9.
348140 08...12	4-Spline socket bit (140mmL) M8; M9; M10; M12.
34805516T	1-Spline security socket bit (55mmL) M16.
34810016T	1-Spline security socket bit (100mmL) M16.
34910013	1-Ribe socket bit (100mmL) M13.
34912012	1-Ribe socket bit (120mmL) M12.
34914009	1-Ribe socket bit (140mmL) M9.
34914010V	1-Ribe socket bit (140mmL) M10V.
674	2-M10 Alternator tools 1pc 1/2"DR. Spline(XZN) socket bit M10x110mmL 1pc Reaction corkscrew cap 33 teeth-Ø19mm-17mm hex
678	2-T50 Alternator tools 1pc 1/2"DR. Star socket bit T50x110mmL 1pc Reaction corkscrew cap 33 teeth-Ø19mm-17mm hex

4/18.8/19.8/1.3' 4700g

31pc 1/4" Bit set

2311



Content:

- 1-Magnetic bit holder 60mmL (81260Q)
- 6-1/4" Phillips bit PH.0, PH.1x2, PH.2x2, PH.3
- 6-1/4" Pozidriv bit PZ.0, PZ.1x2, PZ.2x2, PZ.3
- 4-1/4" Slotted bit 3, 4, 5, 6.5
- 6-1/4" Hex bit 2, 2.5, 3, 4, 5, 6 mm
- 8-1/4" Star tamperproof bit T-10H, T-15H, T-20H, T-25H, T-27H, T-30H, T-35H, T-40H

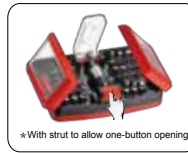

40/12.6/13.6/1.1' 315g

9pc 1/4" & 3/8" Five-sided star tamperproof socket bit set

3095



Content: 1/4"DR. & 3/8"DR.

- 32F32 10...40 7-1/4"DR.: Five-sided star tamperproof socket bit TS10; TS15; TS20; TS25; TS27; TS30; TS40
- 33F50 45...50 2-3/8"DR. Five-sided star tamperproof socket bit TS45; TS50

Bit 30/7/8/0.9' 233g

5pc Specialty set

4059



Content: 1/2"DR.

- 348140 08...12 3-1/2" Spline socket bit M8; M10; M12 (140mmL)
- 34413008 1-1/2" Hex socket bit 8mm (130mmL)
- 34410508B 1-1/2" Bent hex socket bit 8mm (105mmL)

20/13.0/14.0/1.3' 650g

3/8" DR. Universal star socket bit

336...U



Part no.	Tip	l mm	g	pc/box
33645U	T45	65	68	10
33650U	T50	65	70	10

1/2"DR. Bent hex socket bit (8mm)

34410508B



Part no.	size	l mm	g	pcs/box
34410508B	8mm	105	92	10

PH.2 Bits with limiter

121A



Part no	Size	l	30/7/8/0.9'	g
121A252	PH.2	25mm	400/7.8/8.8/1.2'	19.5g
121A502	PH.2	50mm	400/10.2/11.2/1.2'	25.5g

10mm Square bit

174S



Part no.	Size
	mm
174S3008	8
174S3009 NEW	9
174S3010	10
174S3013	13

Angle driver drill tool with quick release

827B03



NEW

- 1/4" Hex shank.
- 1/4" Bit holder with quick release.
- Mini handle attached to quick locking sleeve allows user to rotate 360°.
- Smooth precision turning at 90° position.
- Reach most difficult space.

48/18.7/19.7/0.8' 390g

Magnetic screw bit holder

827B02



Width: 14mm
Length : 24mm

400/3.2/4.2/0.58' 8g

1/4" DR. Universal socket

80525



Part no.		<i>l</i>		
	socket	mm	g	pc/box
8052505	5	39	22	20
8052506	6	39	22	20
8052507	7	39	24	20
8052508	8	39	24	20
8052509	9	39	24	20

1/4" DR. Universal deep socket

8052565



Part no.		<i>l</i>		
	socket	mm	g	pc/box
805256505	5	65	29	20
805256506	6	65	31	20
805256507	7	65	36	20
805256508	8	65	38	20
805256509	9	65	38	20
805256510	10	65	44	20
805256511	11	65	49	20
805256512	12	65	49	20
805256513	13	65	50	20

3/8"DR. Universal socket

80535



Part no.		<i>l</i>		
	socket	mm	g	pc/box
8053510	10	57	64	10
8053511	11	57	66	10
8053512	12	57	67	10
8053513	13	57	67	10
8053514	14	57	70	10
8053515	15	57	77	10
8053516	16	57	78	10
8053517	17	57	82	10
8053518	18	57	92	10
8053519	19	57	92	10
805353.8	3/8"	57	64	10
805357.16	7/16"	57	66	10
805351.2	1/2"	57	67	10
805359.16	9/16"	57	67	10
805355.8	5/8"	57	78	10
8053511.16	11/16"	57	82	10
805353.4	3/4"	57	92	10

3/8"DR. Universal deep socket

8053585





Part no.		<i>l</i>		
	socket	mm	g	pc/box
805358510	10	85	82	10
805358511	11	85	86	10
805358512	12	85	92	10
805358513	13	85	92	10
805358514	14	85	104	10
805358515	15	85	108	10
805358516	16	85	112	10
805358517	17	85	121	10
805358518	18	85	136	10
805358519	19	85	136	10
80535853.8	3/8"	85	82	10
80535857.16	7/16"	85	86	10
80535851.2	1/2"	85	92	10
80535859.16	9/16"	85	92	10
80535855.8	5/8"	85	112	10
805358511.16	11/16"	85	121	10
80535853.4	3/4"	85	136	10

3/8" DR. Star universal socket

80536





Part no.	 socket	<i>l</i> mm	 g	 pc/box
8053606	E6	42	52	10
8053607	E7	42	52	10
8053608	E8	42	56	10
8053610	E10	42	56	10
8053611	E11	42	60	10
8053612	E12	42	60	10
8053614	E14	42	62	10
8053616	E16	42	62	10

1/2" DR. Universal socket

80545





Part no.	 Socket	<i>l</i> mm	 g	 pc/box
8054513	13	67	131	10
8054514	14	67	136	10
8054515	15	67	136	10
8054516	16	67	137	10
8054517	17	67	137	10
8054518	18	67	144	10
8054519	19	67	151	10
8054520	20	67	151	10
8054521	21	67	151	10
8054522	22	67	155	10
8054524	24	67	168	10
805451.2	1/2"	67	130	10
805459.16	9/16"	67	135	10
805455.8	5/8"	67	136	10
8054511.16	11/16"	67	137	10
805453.4	3/4"	67	151	10
8054513.16	13/16"	67	151	10
805457.8	7/8"	67	153	10
8054515.16	15/16"	67	167	10

1/2" DR. Universal deep socket

80545108





Part no.	 Socket	<i>l</i> mm	 g	 pc/box
8054510813	13	108	172	10
8054510814	14	108	179	10
8054510815	15	108	186	10
8054510817	17	108	201	10
8054510819	19	108	222	10
8054510821	21	108	255	10
8054510822	22	108	266	10
8054510824	24	108	283	10
805451081.2	1/2"	108	173	10
805451089.16	9/16"	108	175	10
805451085.8	5/8"	108	179	10
8054510811.16	11/16"	108	192	10
805451083.4	3/4"	108	216	10
8054510813.16	13/16"	108	259	10
805451087.8	7/8"	108	266	10
8054510815.16	15/16"	108	283	10

1/2" DR. Star universal socket

80546



Part no.	 Socket	<i>l</i> mm	 g	 pc/box
8054608	E8	65	124	10
8054610	E10	65	124	10
8054611	E11	65	125	10
8054612	E12	65	127	10
8054614	E14	65	127	10
8054616	E16	65	133	10
8054618	E18	65	133	10
8054620	E20	65	177	10
8054624	E24	65	177	10

1/2"DR. Vacuum switch socket (22. 27mm)

443



Part no.	size	l mm	g	pc/box
44322	22	85	230	10
44327	27	85	389	10
44315022	22	150	450	10

3/4" DR. Star impact deep socket

466110



Part no.	socket	l mm	g	pc/box
46611018	E18	110	520	1
46611020	E20	110	540	1
46611022	E22	110	580	1
46611024	E24	110	591	1
46611028	E28	110	710	1

• E20 For HGV Cylinder-head bolts.

21x28 mm Rectangular deep socket

48311021



- Special design for railway.
- Drive: 1"
- Size: 21 x 28 mm

20/28.8/29.8/0.46' 1440g

6pc 1/2"DR. Star extra-long deep socket set

40616



Part no.	Content:
546150	6-1/2"DR. Star extra-long deep socket (150mmL)
10B...20B	E10; E12; E14; E16; E18; E20

10/17.3/18.3/1.2' 1732g

1/4"DR. Mixture adjuster

601235



1/4" Driver tamperproof mixture adjuster (Double D) for use on Asian and Mikuni carburetors found on Toyota and Mitsubishi cars (35mmL).

200/5.6/6.6/1.3' 28g

1/4"DR. Mixture adjuster

601250



1/4" Driver tamperproof mixture adjuster (fish tail) for use on Nikki and Hitachi carburetors found on Nissan and Subaru cars (50mmL).

200/5.6/6.6/1.3' 28g

T tap wrench (ratchet type)

881



Part no.	Tap range	l mm	g
8812090	1/8"-1/4" (3-6mm)	90	190
8812250	1/8"-1/4" (3-6mm)	250	280
8814110	1/4"-1/2" (6-12mm)	110	320
8814300	1/4"-1/2" (6-12mm)	300	460

6pc Star wrench set

5062



Contents:
756 0608...2024 6-Star wrench
E6xE8; E7xE11; E10xE12;
E14xE18; E16xE22; E20xE24

30/16.7/17.7/1.4' 556g

6pc Extra long flat ring wrench set

50622



Contents:

760 1012...1719 6-Extra long flat ring wrench
10x12; 12x14; 13x15; 14x17;
16x18; 17x19 mm

Tip 12/24.8/25.8/1.2' 2070g

6pc Double gear flat long wrench set

50623



Contents:

827 1012...1719 6-Double gear flat long wrench
10x12; 12x14; 13x15; 14x17;
16x18; 17x19 mm

Tip 12/20.9/21.9/1.2' 1741g

6pc S-form ring wrench set

50634



Contents:

761 1012A...2224A 6pc S-form wrench
10x12; 11x13; 14x15; 16x18;
17x19; 22x24

10/11.0/12.0/1.1' 1100g

6pc Flare nut wrench set

5066 / 5066S



5066 Contents:

751 0810...1719 6-Flare nut wrench
8x10; 10x11; 10x12; 11x13; 12x14; 17x19 mm

5066S Contents:

751 0810S...1719S 6-Flare nut wrench
5/16" x 3/8"; 3/8" x 7/16"; 7/16" x 1/2";
1/2" x 9/16"; 5/8" x 3/4"; 11/16" x 3/4"

30/18.3/19.3/1.3' 610g

Ratchet flare nut wrench

751...A



Part no.	Size mm	<i>l</i> mm	 g	 pc/box
75108A	8	137	84	10
75110A	10	137	85	10
75111A	11	138	88	10
75112A	12	138	82	10
75113A	13	140	91	10
75114A	14	140	86	10
75117A	17	186	146	10
75119A	19	189	157	10



9pc Ratchet flare nut wrench

T50918



Contents:

751 08A...22A 9-Ratchet flare nut wrench
8; 10; 11; 12; 13; 14; 17; 19; 22 mm

6/8.1/9.1/0.66' 1350g

2pc Adjustable wrench set

5023



Part no.	Contents:
649200E	2-Adjustable gauged wrench 8" (200mmL)
649300E	12" (300mmL)

6/9.4/10.4/0.9' 1562g

Adjustable gauged wrench

649...E



Part no.	Size mm	<i>l</i> mm
649200E	24	200
649250E	29	250
649300E	33	300

2pc Auto adjustable wrench

902U2



9U0704

9U0703

- Ideal for track-red ends. Allows leverage in confined areas.
- **9U0703** for use with 3/8"DR. power bar. (40/10.4/11.0/0.6")
- **9U0704** for use with 1/2"DR. power bar. (40/18.0/19.0/1.0")

20/13.8/14.8/0.46' 690g

Adjustable spanner wrench

9U0701



- This tool is ideal for adjusting pillow block bearings.
- Also works well on international model "M" water pump or power takeoff on all.
- Adjustable from 1/2" to 2-3/4".



48/16.1/17.1/1.1' 335g

13pc Hex extra long key set (SAE)

5137XLS



Part no.	
764 1.16XL... 3.4XL	Contents: 13-Hex extra long key 1/16"; 5/64"; 3/32"; 1/8"; 5/32"; 3/16"; 1/4"; 5/16"; 3/8"; 1/2"; 9/16"; 5/8"; 3/4"

6/18.2/19.2/0.68' 3030g

9pc Star & star ball point long key set

5098LB



- Contents:
- 766 10BL...50BL 9-Star & Star ball point long key
 T10; T15; T20; T25; T27;
 T30; T40; T45; T50

Tip 50/16.5/17.5/2.2' 300g

Extra-long spline key M8

76808XL



- Size: Spline M8
- Total length (300mm), for use in hard-to-access areas.

200/23.0/24.0/.96' 115g

1/2" DR. Extension with light

8044080L



Part no.	<i>l</i> mm	 g	 Packing
8044080L	80	360	60/12.6/13.6/1.1'



Flexible extension tube

804...F



- Reach to unreachable corners.
- Delivers high torsion
- Material: SCM 440



Part no.	DR.	<i>l</i> L(mm)	 g	 Packing
8043185F	3/8"	185	300	50/15.0/16.0/0.43'
8044225F	1/2"	225	630	30/18.8/19.8/0.42'

18" Flexible extension

8111L



- 1/4" Drive
- Length: 18", 450mm

100/16.8/17.8/0.9' 168g

Flexible hex nut driver

648



Part no.	size	Blade	over	g	Pc/carton
648055	5.5	160	270	190	60/2.5'
64806	6	160	270	192	60/2.5'
64807	7	160	270	196	60/2.5'
64808	8	160	270	198	60/2.5'
6481.4	1/4"	160	270	192	60/2.5'
6485.16	5/16"	160	270	198	60/2.5'

Flexible hex nut driver

6480607



Part no.	size	Blade	over	g	Pc/carton
6480607	6x7	160	275	220	60/2.5'

Flexible hex nut driver

648...L



Part no.	size	L	over	g	Pc/carton
648055L	5.5	500	630	275	30/1.1'
64806L	6	500	630	275	30/1.1'
64807L	7	500	630	275	30/1.1'
64808L	8	500	630	275	30/1.1'

Extra long screwdriver

655



Part no.	Tip	size	Blade	over	g	pc/box
65511	PH.1	350	450	75	10	
65512	PH.2	350	450	75	10	
65512L	PH.2	400	515	215	10	
65522L	PZ.2	400	515	215	10	
655304	4	300	400	65	10	
655305	5	300	400	65	10	
655306	6	300	400	65	10	
655308	8	300	400	70	5	
6553065L	6.5	400	515	215	10	

7pc Star screwdriver set (300 mmL)

20719



Contents:

716300 10...40 7-Star screwdriver for hard-to-reach fastener
T10; T15; T20; T25; T27; T30; T40 (300mmL)

* Pack in color box

Tip 10/10.3/11.3/1.3' 1030g

Spline screwdriver M4

71817004A



- For removing & fitting the internal covering of tail lamps and dashboards as fitted to the Golf IV & new AUDI / VW models.
- For door handle VW Passat and Golf IV.
- Length: 80mm

Tip M4 35g 10PC

■ Five-sided star tamperproof screwdriver

71F



Part no.	Tip	Blade(mm)	Over(mm)	g	pc/box
71F10	TS10	150	255	62	10
71F15	TS15	150	255	62	10
71F20	TS20	150	255	62	10
71F25	TS25	150	255	73	10
71F27	TS27	150	270	104	10
71F30	TS30	150	270	104	10
71F40	TS40	150	280	146	10

■ 6pc Extra-long screwdriver set

20611



Part no.	Content...
655 11...12	2-Extra-long Phillips screwdriver (350mmL) PH.1; PH.2
6553 04...08	4-Extra-long slotted screwdriver(300mmL) 4;5;6;8mm

10/11.5/12.5/2' 1150g

■ Magnetic base

891B01

NEW

• Holding power: 80kgw



1370g

■ Dial gauge

891A01

NEW



- Range: 0-8mm
- Reading: 0.01mm



65g

■ Auto-rewinder air hose reel

9U0201



- Size: 330 x 150 x 410 mm
- Inlet / Outlet: 1/4"
- Maximum Pressure: 300 PSI
- Hose Length: 15m
- Hose I.D.: 5/16"

3/20/21/3' 6500g

■ Auto-rewinder air hose reel

9U0201A



- Size: 330 x 150 x 410 mm
- Inlet / outlet: 1/4"
- Maximum pressure: 300 PSI
- Hose length: 12M
- Hose I.D.: 3/8"

3/19/20/3' 6335g

High volume air nozzle (slide type)

9U0221

NEW



- Equip the nozzle on pipes, in spiral direction, and tighten the bolt and nozzle onto pipes.
- High volume air nozzle produces triple the air volume of a regular blow gun.
- Inner O-ring attachment design, protect pipes of air blow gun.
- Applicable for any air blow guns with Ø6mm or Ø8mm pipes.



Air blow gun

9U0202 / 9U0203



9U0202

It is suitable for removing and cleaning any kind of chip.

Specification:

- Length: 4" (9U0202) / 13" (9U0203)
- Working pressure: 78~120 PSI / 5~8 KGS
- Thread type: 1/4"



9U0203

9U0202 60/10/11/1.6' 167g

9U0203 50/12/13.5/2.9' 240g

Extendable air blow gun

9U0204 / 9U0205



9U0204

- Special extendable tube and swivel angle can work in any kind of area.

Specification:

- Length: 7~12" (9U0204) / 13"~24" (9U0205)
- Working pressure: 78~120 PSI / 5~8 KGS
- Thread type: 1/4"

Extendable

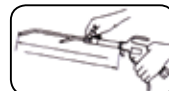

Revolvable

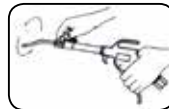

9U0205

9U0204 60/17/18/2.5' 283g

9U0205 50/13/14/2.9' 260g

Multi-functional air blow gun

9U0206

NEW



- The air nozzle is slidable.
- Air volume regulator : Regulator fixed amount of air volume output.
- Suitable for any industries, such as factories, machine tools, vehicles etc.



Air/Hydraulic pump 1600 c.c.

9U4501

NEW



- Usable oil capacity: 1600 cc
- Rated pressure: 10000 psi

2/15.1/16.1/0.8' 1890g

Performance chart											
Pressure (psi)	0	1000	2000	3000	4000	5000	6000	7000	8000	9000	10000
Oil flow (c.c./min)	1250	913	718	598	513	475	393	315	257	233	193

4pc Stud extractor set

5042 / 5042S

- For remove threaded, broken, rusted, stripped or smooth studs.

5042 Contents :

4pc Stud extractor set (MM)
818 06...12 4-Stud extractor 6; 8; 10; 12 mm



5042S Contents :

4pc Stud extractor set (SAE)
818 1.4...7.16 4-Stud extractor 1/4"; 5/16"; 3/8"; 7/16"

20/15.8/16.8/0.74' 790g

7pc Stud extractor set (MM)

5078

- For removing threaded, broken, rusted, stripped or smooth studs.

Contents:

818 05...14 7-Stud extractor
5; 6; 7; 8; 10; 12; 14 mm



12/16.8/17.8/0.73' 1400g

Stud extractor

818



- For remove threaded, broken, rusted, stripped or smooth studs.

Part no.	Drive	size	<i>l</i> mm	 g	 pc/box
81805	3/8"	5	60	127	10
81806	1/2"	6	60	132	10
81807	1/2"	7	60	130	10
81808	1/2"	8	60	130	10
81810	1/2"	10	68	186	10
81812	1/2"	12	68	184	10
81814		14	68	253	10
8183.16	3/8"	3/16"	60	126	10
8181.4	1/2"	1/4"	60	126	10
8185.16	1/2"	5/16"	60	124	10
8183.8	1/2"	3/8"	68	176	10
8187.16	1/2"	7/16"	68	172	10
8181.2		1/2"	68	196	10

Stud extractor

818A



- Socket 1/2" DR. Stud Extractor.
- For remove threaded, stripped, rusted, broken and smooth studs.
- Stud range: 6 - 19mm (1/4" - 3/4")



30/16.9/17.9/0.55' 560g

Stud Extractor

818B



- For removing threaded, broken, rusted, stripped or smooth studs.
- Stud Range: 6 - 12mm (1/4" - 1/2")



Part no.	DR.	<i>l</i> mm	 g	 packing
818B01	3/8"	55	375	48/18.0/19.0/1.8'
818B02	1/2"	75	395	48/19.0/20.0/1.8'

6pc 1/2" DR. Twist socket set

906U2



- Remove damaged bolts or rounded fasteners.

Contents:
5-1/2" DR. Twist socket (50mmL)
17; 19; 21; 23; 27mm



20/19.8/20.8/1.4' 990g

12pc 3/8" & 1/2" DR. Twist socket set

912U3



- Remove damaged bolts or rounded fasteners.

Contents:
4-3/8" DR. Twist socket
8; 10; 12; 13mm
6-1/2" DR. Twist socket
14; 15; 16; 17; 19; 21mm

20/15.5/16.5/0.9' 775g

10pc 3/8" DR. Twist socket set

910U2



- Remove damaged bolts or rounded fasteners.

Contents:
9pc impact socket : mm(inches)
10; 11; 12; 13; 14; 15; 16(5/8"); 17; 19(3/4")
1pc 8mm Straight rod

20/13.5/14.5/0.9' 675g

Bolts & rounded fasteners extractor set

920U3

NEW



- Remove damaged bolts, screws, nuts or rounded fasteners.
- Content:
 - 1ps 3/8" DR. Quick-grip wrench: 8~19mm(5/16"~3/4")
 - 5ps Screw extractor: 1/8"~1/4" (M3~6); 1/4"~5/16" (M6~8) 5/16"~7/16" (M8~11); 7/16"~9/16" (M8~14)9/16"~3/4" (M14~18)
 - 10ps 3/8" DR. Twist socket: 8;10;11;12;13;14;15;16;17;19 mm
 - 1ps L type rod 6mm
 - 1ps Adaptor for 3/8" extension: 3/8"(F) x 3/8"(M)
 - 1ps 3/8" DR Extension: 6"(150 mm)
 - 1ps 3/8" DR Wobble extension: 1.75"(44 mm)



10/14.4/15.4/1.2' 1440g

10pc Combination extractor and drill set

910U1



- Contents five spiral extractors #1 through #5 and five mechanic's length hess drill, removes bolts and screws up to 5/8".
- Left hand extractors with right hand drills.
- Contents:
 - Hess drill size, 5/64", 7/64", 5/32", 1/4", 19/64"
 - Screw extractor size, 5/64", 7/64", 5/32", 1/4", 19/64"

48/16.0/17.0/2.2' 333g

25pc Screw extractor / drill & guide set

925U1



- Fluted type extractors that provide a solid grip on broken studs and screws.
- These screw extractors do not expand the screw while turning and their special design ensures a positive grip when driven into the drilled out hole.
- Drill size is stamped on each extractor for ease of identification.
- Range: 3/16" to 9/16"(5 to 14 mm)



20/11.6/12.6/1.2' 580g

5pc Straight flute screw extractor set

905U1



- Made of chrome molybdenum
- Heat treated
- Quick & easy way to remove broken screws, pipes, bolts & studs
- Size: 3/16" - 5/16" (M5-8)
 - 5/16" - 3/8" (M8-10)
 - 3/8" - 7/16" (M10-12)
 - 7/16" - 9/16" (M12-14)
 - 9/16" - 5/8" (M14-16)

100/17.5/18.5/1' 175g

5pc Screw extractor set

63005 / 63005B



63005



63005B

- Size: 1/8" - 1/4" (M3-6)
 - 1/4" - 5/16" (M6-8)
 - 5/16" - 7/16" (M8-11)
 - 7/16" - 9/16" (M8-14)
 - 9/16" - 3/4" (M14-18)



100/13.7/14.7/1.4' 137g

8pc Screw extractor set

63006 / 63006B



63006



63006B

- Size: 1/8" - 1/4" (M3-6)
 - 1/4" - 5/16" (M6-8)
 - 5/16" - 7/16" (M8-11)
 - 7/16" - 9/16" (M11-14)
 - 9/16" - 3/4" (M14-18)
 - 3/4" - 1" (M18-25)
 - 1" - 1-1/8" (M25-28)
 - 1-1/8" - 1-1/4" (M28-32)

24/19.9/20.9/0.77' 830g

8pc Torx plus extractor set

908U2

NEW



- Special design of torx plus head, twist body with teeth and tap shape.
- High efficiency to remove damaged objects as below:
 - Hex inside (not stripped)
 - Stripped hex inside
 - Round inside
 - Stripped round inside
 - Torx / torx plus / torx security inside
 - Stripped torx / torx plus / torx security inside 7
- Application size: 3mm(3.4~4.6mm), 4mm(4.3~5.9mm), 5mm (5.3~7.0mm), 6mm(6.3~8.1mm), 7mm (7.4~9.2mm), 8mm (8.4~10.4mm), 10mm(10.4~12.6mm), 12mm(12.4~14.0mm)

20/10/11/0.6'

373g

9pc Torx plus extractor set

909U1

NEW



- Special design of torx plus head, twist body with teeth and tap shape.
- High efficiency to remove damaged objects as below:
 - Hex inside (not stripped)
 - Stripped hex inside
 - Round inside
 - Stripped round inside
 - Torx / torx plus / torx security inside
 - Stripped torx / torx plus / torx security inside 7
- Application size: T6(1.5~2.7mm), T7(1.7~2.9mm), T8 (2~3.4mm), T9(2.2~3.7mm), T10 (2.6~4.0mm), T15 (3.4~4.8mm), T20(3.6~5.0mm), T25(4.2~5.8mm)

50/10/11/0.75'

183g

130pc Threaded coil-insert repair kit

9130U1

Contents:

- Screw-Coil: Material: Stainless Steel SUS304.
25pc M5-0.8*1.5D, 25pc M6-1.0*1.5D, 25pc M8-1.25*1.5D, 25pc M10-1.5*1.5D, 10pc M12-1.75*1.5D.
- Tap: Material: HSS.
1pc M5-0.8, 1pc M6-1.0, 1pc M8-1.25, 1pc M10-1.5, 1pc M12-1.75.
- Tang Puncher: Material: Carbon Steel.
1pc M5-0.8, 1pc M6-1.0, 1pc M8-1.25, 1pc M10-1.5, 1pc M12-1.75.
- Drill: Material: HSS.
1pc 5.2mm, 1pc 6.3mm, 1pc 8.3mm, 1pc 10.4mm, 1pc 12.4mm.
- Main Tool: Material: Steel.
1pc M5-0.8, 1pc M6-1.0, 1pc M8-1.25, 1pc M10-1.5, 1pc M12-1.75.



8/19.5/20.5/1.2'

2437g

Threaded coil-insert repair kit

929../924../912../910..



Part no.	Size	pc	Packing	g
929U1	M5x0.8	29	30/8.2/9.2/1.7'	275
929U2	M6x1.0	29	30/9.2/10.2/1.7'	310
929U3	M8x1.25	29	30/11.6/12.6/1.7'	390
924U2	M10x1.0	24	30/13.8/14.8/1.7'	460
924U3	M10x1.25	24	30/13.8/14.8/1.7'	460
924U5	M10x1.5	24	30/13.8/14.8/1.7'	460
912U5	M12x1.25	12	30/16.5/17.5/1.7'	550
912U6	M12x1.5	12	30/16.5/17.5/1.7'	550
912U7	M12x1.75	12	30/16.5/17.5/1.7'	550
910U5	M14x1.25	10	30/18.6/19.6/1.7'	620
910U6	M14x1.5	10	30/18.6/19.6/1.7'	620

8pc Axle spindle rethreading set

67001



- 8pcs thread restoring die set is used to clean or repair axle threads on spindles.
- Use with 1-1/4" socket or wrench.
- Size: M24x1.50; M24x2.00; M22x1.00; M22x1.50; M20x1.50; M20x1.25; 3/4"x20UNEF; 13/16"x20UNEF



20/12/13/0.6'

600g

20pc Master spindle rethreading set

920U1



- This 20-piece set will repair or renew damaged threads on stub axles / spindles on most vehicles. Dies are made of high tempered steel for strength and durability. All dies have the same 1-1/4" (32mm) hex size. Stored in high impact blow mold case.
- Imperial sizes: 11/16"x24, 3/4"x16, 3/4"x20, 13/16"x20, 27/32"x20, 7/8"x14, 1"x14
- Metric sizes: 16x1.0, 16x1.5, 18x1.5, 19x1.5, 20x1.0, 20x1.25, 20x1.5, 22x1.0, 22x1.5, 24x1.5, 24x2.0, 25x1.5, 27x2.0

6/11.3/12.3/1.3'

1883g

15pc Metric rethreader set

915U1



Contents:

- Seven metric rethreader dies, seven metric rethreader taps, one metric thread file.
- Rethreader die sizes:
6x1.00, 8x1.25, 10x1.25, 10x1.50, 12x1.25, 12x1.5, 12x1.75mm
- Rethreader tap sizes:
6x1.00, 8x1.25, 10x1.25, 10x1.50, 12x1.25, 12x1.5, 12x1.75mm
- 1pc metric thread file



10/6.2/7.2/0.57' 620g

43pc UNF, UNC & Metric rethreader set

943U1



Contents:

Seven UNC, seven UNF and seven metric rethreader dies, six UNC, six UNF and seven metric rethreader taps, one UNF and UNC thread file and one metric thread file.

- Rethreader Die Sizes:
1/4", 5/16", 3/8", 7/16", 1/2", 9/16", & 5/8", UNC 1/4", 5/16", 3/8", 7/16", 1/2", 9/16", & 5/8", UNF 6x1.00, 8x1.25, 10x1.25, 10x1.50, 12x1.25, 12x1.5, 12x1.75mm
- Rethreader Tap Sizes:
1/4", 5/16", 3/8", 7/16", 1/2", & 9/16", UNC
1/4", 5/16", 3/8", 7/16", 1/2", & 9/16", UNF
6x1.00, 8x1.25, 10x1.25, 10x1.50, 12x1.25, 12x1.5, 12x1.75mm
- Description Pitch Sizes:
Metric file 0.75, 1.00, 1.25, 1.75, 2.00, 2.50 and 3.0mm SAE file 11, 12, 13, 14, 16, 18, 20, and 24 SAE file 9, 10, 12, 16, 20, 27, 28 and 32

6/11.0/12.0/0.7' 1833g

External thread restorer files

66901 / 66902 / 66903



66901 Contents:

Metric file / Pitch size : 0.75; 1.00; 1.25; 1.50; 1.75; 2.00; 2.50; 3.00

66902 Contents:

SAE file / Pitch size : 11; 12; 13; 14; 16; 18; 20; 24

66903 Contents:

SAE file / Pitch size : 9; 10; 12; 16; 20; 27; 28; 32

- Restore tool for renewing damaged thread on any diameter bolt, stud, axle of shaft file, both right and left threads.

72/15.0/16.0/1.2' 208g



External & internal restorer file

9U1101 / 9U1102



- Restorer tool for renewing damaged thread on bolt, stud, axle or shaft of any diameter. File both right and left hand threads.
- Designed for use in hidden & narrow area.
- Description pitch sizes:

9U1101

Metric File : 0.80-1.00-1.25-1.50-1.75-2.00-2.50-3.00

9U1102

SAE file : 24-20-18-16-14-12-11-10

120/19.7/20.7/1.7' 164g



7pc Square thread tap set

907U2



SAE:

- 1 : 4N, 5N, 6N, 7N
- 2 : 7-1/2N, 9N, 11N, 11-1/2N
- 3 : 8N, 10N, 12N, 14N
- 4 : 16N, 18N, 20N, 24N

Metric:

- 5 : 1P, 1.25P, 1.5P, 1.75P
- 6 : 2P, 2.5P, 3P, 3.5P
- 7 : 4P

100/14.2/15.2/0.61' 142g

4pc Nut splitter set

672



Contents:

- 6720912 1pc 5/16"to 1/2" (9-12mm)
- 6721216 1pc 1/2" to 5/8" (12-16mm)
- 6721622 1pc 5/8" to 7/8" (16-22mm)
- 6722227 1pc 7/8" to 1-1/8" (22-27mm)



12/18.5/19.5/0.87' 1540g

Universal nut cracker

9U1001



- Splits most stubborn nuts 7/16" (11mm) through 3/4" (19mm) across the flats.
- Works in channels not accessible by other tools.
- Parallel action of pusher cracks nuts without damaging bolt threads. Chisel rotates 360° to line up parallel to bolt. Simply tighten the screw until the nut splits.
- With a rugged drop-forged frame.
- Do not use on heat-treated nuts.
- Length: 6-3/4" serviceable product.



24/15.5/16.5/1' 645g

Recoilless hammer (head-replaceable)

616A



Part no.	<i>l</i> mm	 g	 packing
616A025	25	389	48/16/18/1.24'
616A030	30	435	72/23/25/1.3'
616A035	35	505	48/26/28/1.4'
616A040	40	606	24/21/23/0.92'
616A045	45	865	24/24/26/1.1'
616A050	50	952	24/27/29/1.26'
616A055	55	1038	18/22/24/1.3'
616A060	60	1125	18/30/31/1.58'

- Steel handle with positive plastic grip.
- PU-material strike faces.
- Both strike faces can be repeatedly changed if broken.

Soft face hammer

616A400



- Hammer head: 1 yellow PU + 1 white Nylon
- Handle: natural color hickory

48/19.9/21.8/1.62' 415g

Soft face hammer

616A700



- Hammer head:black TPR & transparent yellow acetate head
- Handle: 1.4mm harden tubular steel handle, PVC ring & A type PVC grip

24/20.2/21.4/0.91' 842g

Sledge hammers

616G....



NEW

Part no.	Head Weight g	Total Length mm	Packing
616G1250	1250	260	16/22.6/23.6/0.68'
616G1500	1500	280	12/21.6/22.4/0.59'

Brass taper punch 3/8", 5/8"hex

606B200



- Length: 8"(200mm)

5pc Chisel set

50510



Contents:

602 10150...22200 5-Chisel
 10(150mmL); 12(150mmL);
 15(180mmL); 19(200mmL);
 22(200mmL)

30/26.6/27.6/0.5' 887g

6pc Pin punch set

50613



Contents:

604 2140...8215 6-Pin punch
 2mm (140mmL); 3mm (150mmL)
 4mm (190mmL); 5mm (200mmL)
 6mm (210mmL); 8mm (215mmL)



30/16.7/17.7/1.3' 540g

Ribbed (Cold) chisel

602...C



Part no.	Size mm	<i>l</i> mm	 g
60218125C	18	125	90
60221150C	21	150	155
60226200C	26	200	320
60229250C	29	250	470
60234300C	34	300	750

Ribbed (Cold) chisel with sheath handle

602...Q



Part no.	Size mm	<i>l</i> mm	 g
60229250Q	29	250	540
60234300Q	34	300	820

6pc Chisel & punch set (long type, interchangeable)

906U1



Contents:

- 1pc Main handle / 1pc Flat chisel 13mm
- 1pc Center punch 3mm / 3pc Pin punch 3; 4; 5mm
- Material and shape: Main handle made by carbon steel; bits made by chrome-vanadium. All shank 10mm hex with two grooves.
- Comfortable and protective handle
- Double locking device holding tight
- Save space, time and money
- Create high efficiency

Warning: Wear safety goggles when in use; chisel and punch shanks have to be inserted to hole bottom.

48/31.2/32.2/3.3' 650g

15pc Chisel & punch set (interchangeable)

915U3



- Material and shape: Main handle made from Chrome-Vanadium; Bits made by Chrome-Vanadium. All shank 13mm hex with two grooves.
- Comfortable and protective handle
- Double locking device holding tight

Warning: Wear safety goggles when in use; chisel and punch shanks have to be inserted to hole bottom.

10/22.5/23.5/1.8' 2250g

15pc Hammer chisel & punch set (interchangeable)

915U4



- Material: Main hammer made from drop forged carbon steel; bits made by chrome-vanadium.
- Safe and comfortable handle of hammer.
- Double locking device holding tight

Warning: Wear safety goggles when in use; chisel and punch shanks have to be inserted to hole bottom.

10/24.0/25.5/2.4' 2400g

13pc Tungsten carbide tipped metal borer set

913U1 / 913U2



- Use the same arbor for saw heads of different sizes.
- Change saw heads with a simple push and turn the fixed screw.
- H.S.S. center drill is replaceable.
- Shank size of the arbor is 3/8".
- Spring can help slug removal.

Contents:

- 1pc Arbor
- 1pc Spring
- 2pc H.S.S center pilot drill 75; 84 mm
- 2pc Hex key 3; 4.0 mm

913U1 7pc Saw head 19; 22; 25; 28; 30; 32; 35 mm

913U2 7pc Saw head 30; 32; 35; 38; 40; 45; 51 mm

10/15.7/16.7/1.4' 1570g

Tapered reamer

9U0901 / 9U0902



- Ream, deburr, align, and enlarge holes. T-handle makes turning easy.
- Reamer is made of high-grade heat-treated tool steel for long life.
- To avoid damage tool, it must always be turned clockwise. The use of cutting oil is recommended.



9U0901 Capacity: 1/8" to 3/8" (3mm to 10mm)

9U0902 Capacity: 5/32" To 17/32" (4mm To 31mm)

Part no.	packing	g
9U0901	240/16.8/17.8/1.4'	70
9U0902	48/16.6/17.6/1.3'	345

Rivet pliers

67801



Part no.	packing	mm	g
67801	20/15.7/16.7/2.1'	180	785

- Riveting capacity

	Rivet material	
	Rivet diameter	Aluminum
	Ø2.4mm or Ø3/32"	▲
	Ø3.0/3.2mm or Ø1/8"	▲
	Ø4.0mm or Ø5/32"	▲
	Ø4.8/5.0mm or Ø3/16"	▲

Grade nut fastener

67802



Part no.	packing	mm	g
67802	20/11.6/12.6/2.1'	280	582

- Size: M3, M4, M5, M6

Hand riveter

678260

NEW



30/17.3/18.3/1.5' 556g

- Rivet size: Ø2.4mm (Ø3/32"); Ø3.0, 3.2mm (Ø1/8"); Ø4.0mm (Ø5/32"); Ø4.8, 5.0mm (Ø3/16")
- High-grade heavy-duty steel plate upper handle with advanced heat treatment, high-strength aluminum body, high-grade steel alloy key parts (jaws, jaw case, fulcrum pin, etc) with advanced heat treatment, PAHs-Free (non-toxic to hand skin) plastic hand grips.

- Riveting capacity

	Rivet material			
	Rivet diameter	Aluminum	Steel	Stainless Steel/Inox
	Ø2.4mm or Ø3/32"	▲	■	●
	Ø3.0/3.2mm or Ø1/8"	▲	■	●
	Ø4.0mm or Ø5/32"	▲	■	●
	Ø4.8/5.0mm or Ø3/16"	▲	■	

Heavy-duty 2-handled lever type riveter

678535

NEW

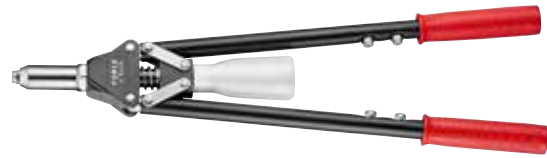

- Cap: Ø3.0mm ~ Ø6.4mm
- Blind rivets: Ø1/8" ~ Ø1/4"

• Riveting capacity

Rivet diameter	Rivet material		
	Aluminum	Steel	Stainless Steel/Inox
Ø3.0/3.2mm or Ø1/8"	▲	■	●
Ø4.0mm or Ø5/32"	▲	■	●
Ø4.8/5.0mm or Ø3/16"	▲	■	●
Ø6.0mm	▲	■	●
Ø6.4mm or Ø1/4"	▲	■	●

10/17.5/18.5/1.6' 1890g

Heavy-duty lazy tong type riveter

678810

NEW

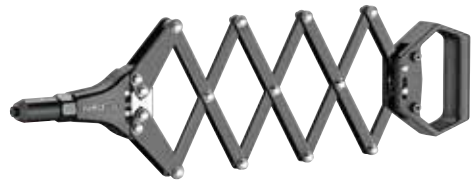

- Cap: Ø3.0mm ~ Ø6.4mm
- Blind rivets: Ø1/8" ~ Ø1/4"

• Riveting capacity

Rivet diameter	Rivet material		
	Aluminum	Steel	Stainless Steel/Inox
Ø3.0/3.2mm or Ø1/8"	▲	■	●
Ø4.0mm or Ø5/32"	▲	■	●
Ø4.8/5.0mm or Ø3/16"	▲	■	●
Ø6.0mm	▲	■	●
Ø6.4mm or Ø1/4"	▲	■	●

10/19.5/20.5/1.4' 1845g

Hand nut riveter(M3~M8)

678N260

NEW



- With 5 short type threaded mandrels M3 ~ M8.
- With 4 nosepieces M3 ~ M6 (M8 does not need nosepiece).
- Forged steel upper handle with advanced heat treatment, high strength aluminum body with steel insert design.
- Stroke adjuster design.

• Riveting capacity

Rivet Nut Thread Size	Rivet Nut Material		
	Aluminum	Steel	Stainless Steel / Inox
M3x0.5 or 6-32 Rivet Nut	▲	■	●
M4x0.7 or 8-32 Rivet Nut	▲	■	●
M5x0.8 or 10-24, 10-32 Rivet Nut	▲	■	●
M6x1.0 or 1/4-20 Rivet Nut	▲	■	●
M8x1.25 or 5/16-18 Rivet Nut	▲	■	●

30/17.3/18.3/1.5' 640g

Heavy-duty hand nut riveter(M4~M10)

678N320

NEW



- With 5 short type threaded mandrels M4 ~ M10 and 5 Nosepieces M4 ~ M10.
- High tension steel short handle with super leverage design, high strength aluminum bodies.
- Special design to solve the headache problem of rivet nut stuck with threaded mandrel.
- Stroke adjuster design with stroke indicator.
- Mandrel length adjustable design.

• Riveting capacity

Rivet Nut Thread Size	Rivet Nut Material		
	Aluminum	Steel	Stainless Steel / Inox
M4x0.7 or 8-32 Rivet Nut	▲	■	●
M5x0.8 or 10-24, 10-32 Rivet Nut	▲	■	●
M6x1.0 or 1/4-20 Rivet Nut	▲	■	●
M8x1.25 or 5/16-18 Rivet Nut	▲	■	●
M10x1.5 or 3/8-16 Rivet Nut	▲	■	●

10/17.5/18.5/1.6' 860g

Grey cast iron bench vise (without base)

65401



Part no.	Jaw open	Throat depth	packing
6540104	4"	2-5/8"	1/12.2/13.2/0.43'
6540105	5"	3-1/4"	1/13.7/14.7/0.6'
6540106	6"	3-3/4"	1/19.6/20.6/0.82'
6540108	8"	4"	1/26.8/27.8/0.97'

Drilling press vise

65404



Part no.	Jaw Open	Throat Depth	Packing
6540403	2-3/4"	3/4"	2/3.2/4.2/0.16'
6540404	4"	1"	2/6.2/7.2/0.24'
6540405	5"	1"	2/11.0/12.0/0.3'
6540406	5-1/2"	1"	2/13.5/14.5/0.43'

■ Cross vise

65405



Part no.	Jaw	Packing
	Open	
6540503	3"	1/6.2/7.2/0.31'
6540504	4"	1/10.0/11.0/0.44'
6540505	5"	1/13.5/14.5/0.5'
6540506	6"	1/16.5/17.5/0.65'

■ Forged steel bench vise

65406



Item No.	Jaw opening	Weight (kg)	Packing
6540604	4"	8.4	1/8.4/9.4/0.3'
6540605	5"	12.5	1/11.5/12.5/0.63'
6540606	6"	20.5	1/19.5/20.5/1.02'

■ Heavy duty bench vise

65402..A



Part no.	Size	Weight(kg)	packing
6540204A	4"	7.7	1/7.3/8.3/0.36'
6540205A	5"	11.2	1/11/12/0.48'
6540206A	6"	14.5	1/14/15/0.57'
6540208A	8"	19.2	1/19.2/20.2/0.91'
6540210A	10"	25.6	1/27/29/1.4'



The nut and the base are one-piece forged, instead of being jointed together later by screws. The strengthened structure ensures the firm and steady joint between the base and the lead screw, and thus the jaws can provide you with powerful and sturdy grip to weighty pieces.

■ Heavy duty ductile octagonal supporting vise

65407



Part no.	Size	Weight(kg)	packing
6540706	6"	28	1/27/28/0.85'
6540708	8"	40.5	1/41/42/1.43'

The nut fits completely into the jaw. The nut which is not movable mates and works precisely with the lead screw.

■ Heavy duty ductile square supporting vise

65408

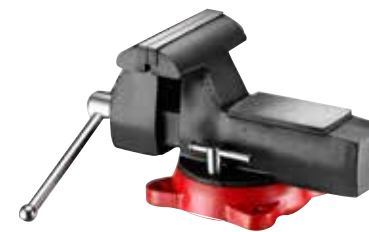

Part no.	Size	Weight(kg)	packing
6540804	4"	15	1/15/16/0.5'
6540805	5"	17	1/17/18/0.53'
6540806	6"	18.6	1/18.6/19.6/0.6'

The nut fits completely into the jaw. The nut which is not movable mates and works precisely with the lead screw.

■ Scriber of wolfram steel

87901



Part no.	<i>l</i>	g
	mm	
87901	145	20

• Include one tungsten lead and one carbon lead.

■ Straight shears

5055P1



Part no.	Cutting Length	<i>l</i>	g	packing
		mm		
5055P1	51mm	265-10.5"	480	36/17/18/1.3'
5055P112	70mm	305-12"	650	24/21/23/1.2'

Aviation tin snips

698



Part no.	Direction	<i>l</i> mm	<i>l</i> CuttingL	 g	 packing
6981250	Straight cut	250	38mm	400	60/24/15/1.86'
698L248	Left cut	248	35mm	400	60/24/25/1.86'
698R248	Right cut	248	35mm	400	60/24/25/1.86'

Stainless steel pvc pipe cutter

65607



- For 40mm O.D. PVC pipe
- Part: Cutting wheel (**65607-B**)
- Weight:490g
- Length:225mm



30/16.2/17.2/2.2' 540g

Locking pliers (straight jaw)

614A



Part no.	<i>l</i> mm-inch	 packing	 g
614A175	175-7"	40/16.4/17.4/0.96'	380
614A250	250-10"	40/23.2/24.2/1.0'	580

Locking pliers (V-jaw)

614B225



Part no.	<i>l</i> mm-inch	 packing	 g
614B225	225-9"	40/23.0/24.0/1'	575

Locking pliers

614



Part no.	 packing	<i>l</i> mm	 g
614125	40/7.6/8.6/0.7'	125-5"	190
614175	40/14.8/15.8/0.96'	175-7"	370
614250	40/22.0/23.0/1'	250-10"	550

Long nose locking pliers

615



Part no.	 packing	<i>l</i> mm	 g
615150	50/10.3/11.3/1.1"	150-6"	220
615225	50/19.5/20.5/1.2"	225-9"	390

Adjustable locking pliers

65202



Part no.	Jaw mm	<i>l</i> Length	 g
	3-46	9"(215mm)	400



- For clamping plumbing and worn screws
- Can be adjusted for clamping small to large screws
- Smooth and fast screw clamping and releasing
- Material: Jaw Cr-Mo; Body: Cr-Mo

50/20/21/1' 400g

Wire twisting pliers

6958



Part no.	<i>l</i> mm	 g	 Packing
6958160	160	220	80/19.0/20.0/1.1'
6958225	225	360	60/26/27/2.1'



Wire rope cutter

6959180



Part no.	<i>l</i> mm	 g	 Packing
6959180	180	280	60/17.0/18.0/1.1'

Parallel jaw lock ring pliers

9T0101



- Features heavy drop forged 10" external action lock ring pliers
- Features compound leverage action.
- The thin jaws are notched to securely hold snap rings and they open in a parallel plane.
- Ideal for working on automatic transmissions.
- Spread: 1.1/16"(27mm)
- Length: 10"(250mm)



36/14.2/15.2/1.7' 395g

Straight tip lock ring pliers

9T0103



- Features heavy drop forged tips with wider opening for standard transmissions.
- Tip: flat, straight, serrated.
- Spread: 1-1/2" (38mm)
- Length: 9" (230mm)

48/14.6/15.6/0.75' 300g

Angled tip lock ring pliers

9T0104



- Features heavy drop forged tips with wider opening for standard transmissions.
- Tip: flat, angled, serrated.
- Spread: 1-1/2"(38mm)
- Length: 9"(230mm)

48/14.4/15.4/0.75' 300g

Internal lock ring pliers

9T0105



- Wide flat jaws designed for easy removal of lock rings on transmissions, differentials, shafts etc.
- Spring return handles.

36/14.6/15.6/0.8' 400g

Snap ring pliers (internal 90° bent tip)

609...ABC



Part no.	Capacity	Tip		<i>l</i>	
	mm	mm	packing	mm	g
60905ABC	8-25	1.3	30/2.4/3.4/0.44'	140-5.5"	80
609ABC	19-60	1.9	30/4.5/5.5/0.7'	180-7"	150
60909ABC	40-100	2.3	30/9.0/11.0/1.2'	230-9"	300
60912ABC	85-165	3.2	30/16.5/17.5/1.8'	310-12"	465

• 60912ABC is without a spring.

Snap ring pliers (external 90° bent tip)

609...ABO



Part no.	Capacity	Tip		<i>l</i>	
	mm	mm	packing	mm	g
60905ABO	8-25	1.3	30/2.4/3.4/0.44'	140-5.5"	80
609ABO	19-60	1.9	30/4.5/5.5/0.7'	180-7"	150
60909ABO	40-100	2.3	30/9.0/11.0/1.2'	230-9"	300
60912ABO	85-165	3.2	30/16.5/17.5/1.8'	310-12"	510

Snap ring pliers (internal straight tip)

609...ASC

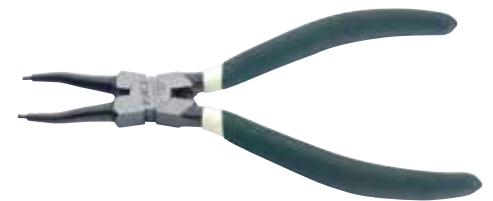

Part no.	Capacity	Tip		<i>l</i>	
	mm	mm	packing	mm	g
60905ASC	8-25	1.3	30/2.4/3.4/0.44'	140-5.5"	80
609ASC	19-60	1.9	30/4.5/5.5/0.7'	180-7"	150
60909ASC	40-100	2.3	30/9.0/11.0/1.2'	230-9"	300
60912ASC	85-165	3.2	30/16.5/17.5/1.8'	310-12"	470

• 60912ASC is without a spring.

■ Snap ring pliers (external straight tip)

609...ASO

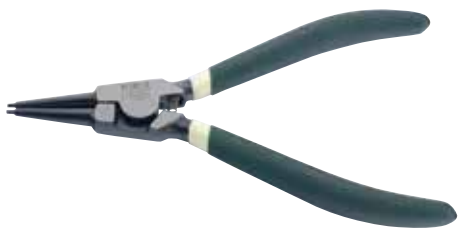

Part no.	Capacity mm	Tip mm	packing	l mm	g
60905ASO	8-25	1.3	30/2.4/3.4/0.44'	140-5.5"	80
609ASO	19-60	1.9	30/4.5/5.5/0.7'	180-7"	150
60909ASO	40-100	2.3	30/9.0/11.0/1.2'	230-9"	300
60912ASO	85-165	3.2	30/16.2/17.2/1.3'	310-12"	490

■ Internal snap ring pliers (long arm)

9U0102



- Special design for the retaining ring in the deep hole.
- The most deep size: 56mm

6/19.8/20.8/2.3' 240g

■ 3pc Heavy-duty lock ring pliers set

903U1



- Serrated angled flat tips retaining screws.
- Designed for heavy-duty service on external lock rings used in truck and tractor transmissions.
- Replaceable tips.
- Extra leverage from long spring loaded handles.
- Spread: 3" (75mm)
- Length: 14" (355mm)



36/21.5/23/1.4' 545g

■ 4pc Internal-external snap ring pliers set

904U3



- Effective range: 10 – 50 mm (3/8" – 2")
- Includes four pieces exchangeable tips
- 2pc straight tips
- 1pc 90° angled tips
- 1pc 45° angled tips
- Jaws can be exchanged easily for 6 internal-external different purposes.



60/12/14/2.5' 200g

■ 12pc Internal-external circlip pliers set

912U1



- Feature replaceable points and spring ratchet locking mechanism to securely hold against circlip tension.
- Internal: 3-1/16" - 6-1/4"
- External: 3-1/2" - 6-1/2"
- Tip diameter: 0.12" (3mm)
- Spread: 3-1/4" (85mm)
- Length: 16" (400mm)

6/19.8/20.8/2.3' 3300g

■ 20pc Internal-external circlip pliers set

920U2



- Feature replaceable tips and spring ratchet locking mechanism to securely hold against tension. Offset tips make it easier to facilitate circlip.

- Internal: 2-1/16" – 6-1/4"
- External: 3-1/2" – 6-1/2"

- Replaceable tips:

Qty	Tip size	Tip angle
2	0.108	0°
2	0.108	15°
2	0.108	45°
2	0.108	90°
2	0.120	0°
2	0.120	15°
2	0.120	45°
2	0.120	90°

10/13.5/15.0/1.6 1.35kg

■ 10pc Universal locking tool set

910U3



- The multipurpose 9-1/2" pliers with five attachments.
- Parts are interchangeable depending on the desired functions and purpose.

10/13.1/14.1/1.3' 1310g

Pipe wrench

684



Part no.	packing	Length	g
68408	36/14.0/15.0/0.4'	200-8"	390
68410	24/17.0/18.0/0.4'	250-10"	710
68412	24/23.0/24.0/0.5'	300-12"	960
68414	12/16.0/17.0/0.4'	355-14"	1340
68418	12/25.0/26.0/0.6'	455-18"	2090
68424	6/22.0/23.0/0.7'	610-24"	3670
68436	3/25.0/26.0/1.1'	863-36"	8340
68448	2/24.0/25.0/1.0'	1220-48"	12000



Aluminum pipe wrench

684...A



Part no.	packing	Length	g
68410A	24/11.0/12.0/0.4'	250-10"	460
68412A	24/17.0/18.0/0.4'	300-12"	700
68414A	24/21.5/22.5/0.5'	355-14"	895
68418A	12/18.0/19.0/0.9'	455-18"	1500
68424A	6/14.0/15.0/0.7'	610-24"	2330
68436A	3/14.0/15.0/1.1'	863-36"	4660
68448A	2/13.0/14.0/1.0'	1220-48"	6500



Pipe wrench

684C



Part no.	size	Length	packing	g
684C14	1	350mm(14")	20/15.8/16.8/0.78'	790
684C17	1-1/2	440mm(17")	16/23.2/24.2/1.7'	1450
684C22	2	560mm(22")	8/18.8/19.8/1.6'	2350

Pipe torque wrench

647P...



Part no.	Torque	Length	kg
	Nm	mm	
647P210	40-210	590	3
647P350	70-350	825	3.7
647P500	100-500	920	4.6

*Accuracy: +6%

Pipe gripping pliers

6957240



Part no.	Packing	mm	g
6957240	60/19.2/20.2/1.6'	240	320

10pc Tubing cutter & double flaring tool set

656A / 656AM



Contents:

- 1-Flaring tool
- 1-Flare bar
- Size of flare bar and adapters:
S.A.E.: 3/16", 1/4", 5/16", 3/8", 7/16", 1/2" & 5/8"
- 1-Heavy duty tube cutter: 1/8"-1/18"

• This 2-in-1 flaring tool set is designed to withstand the high pressures necessary to double flare soft steel tubing, as well as, single flare soft copper, aluminum and brass tubing. Automotive 45°.

656AM Changed item

- 1-Flare bar
- Size of flare bar and adapters:
Metric: 4-4.75-6-8-10-12-14mm
- 1-Heavy duty tube cutter: 4-28mm



7pc Double flaring tool kit

656F



Contents:

- 1-Flaring tool
- 1-Flare bar: includes 5 size:
S.A.E.: 3/16", 1/4", 5/16", 3/8" & 1/2"
- 5-Flare adapters:
S.A.E.: 3/16", 1/4", 5/16", 3/8" & 1/2"

This 45° double flaring tool is designed for S.A.E. size tubing and will withstand pressure that is necessary for double flare tubing up to 1mm wall thickness. Tool can be used as a single flaring tool.

10pc Tubing cutter and double flaring tools kit

656 / 656M



- 1pc Tubing cutter.
- 1pc 9/16" Screen bar.
- 7pc Adaptor 3/16"; 1/4"; 5/16"; 3/8"; 7/16"; 1/2"; 5/8"

656M Changed item:

- 7pc Adaptor 4; 6; 8; 10; 12; 14; 16 mm

12/18.6/19.6/1.5' 1610g

Professional universal flaring tool

906T2



- Tool works in two steps for thin walled steel, aluminum or copper pipes.
- For dimensions of 3/16" (4.75mm) and 1/4" (6mm)
- Fast manual flaring tool with minimal material wastage.



4/22.0/23.0/2' 4300g

Hydraulic flaring tool kit

656B



- SAE:3/16";1/4"
- DIN:3/16"; 1/4"



6/15/16/1.5' 2330g

Hydraulic flaring tool kit

656BM



- Use in-site on the vehicle and suitable for producing SAE (3/16" & 1/4") and DIN 45 degree (3/16" & 1/4") flares.
- Capable of working on steel brake pipes.
- 4.75; 5; 6 mm



6/15.5/16.3/1.4' 2584g

Universal hydraulic flaring tool set

656B01

NEW

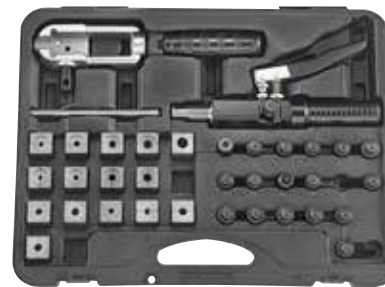

- A quality flaring tool set containing a hydraulic flaring tool capable of 6 tons of pressure and a range of dies and adaptors suitable for:
 1. Push connect: 1/4", 5/16", 3/8", 1/2"
 2. GM fuel line flare: 5/16", 3/8"
 3. 45° & Double flare: 3/16", 1/4", 5/16", 3/8", 1/2"
 4. Metric bubble flare: 4.75mm, 6mm, 8mm, 10mm
 5. GM-TC: 3/8", 1/2"

2/13/14/1.2' 6664g

45° Eccentric flaring tool for R410A

65641

NEW



- Engineered to create stronger flare joints for high pressure R410A systems.
- Unique clutch driven feed screw and faceted cone produce uniform, clean flare walls without thin spots or galling.
- For 45° flaring of 1/4", 5/16", 3/8", 1/2", 5/8", 3/4" O.D. tubing.

1385g

3-in-1 Tubing bender

653



Part no.	Application size	packing	g
65301	6;8;10mm	50/17.4/18.4/2'	348
65302	1/4";5/16";3/8"	50/19.5/20.5/2'	390



180° 3-in-1 Tube bender

653180



- Quality aluminum body
- Three size tube bender
Inch: 1/4", 5/16", 3/8"
Metric: 6mm, 8mm, 10mm

20/10.9/11.9/2' 545g

Breakline bending pliers

65303



- SIZE: 3/16", 1/4"

50/20.5/21.5/0.85' 420g



Tubing bending pliers

65305



- For bending brass, copper, aluminum and steel tubing.
- Tubing bender pliers feature one rollers.
- One roller accepts 3/16" / 1/4" / 5/16" / 3/8" (4.8 / 6.4 / 7.9 / 9.5mm) O.D. tubing.

8/20.0/21.0/0.8' 2500g

Tube straightener tool

65306

NEW



- Straighten coils of brake pipe quickly and easily.
- For use on most types of tubing including soft metal tube, copper and stainless steel.
- Size ranges from 3/16"-1/2" (4.75 - 12.7 mm)

6526g

Iron pipe cutter

65605



- For 1/8"-2" (3mm-50mm) O.D. iron pipe
- Part: Cutting wheel (65605-B)
- 43cm
- 3100g

6/18.6/19.6/1.9' 3100g

Telescopic tubing cutter

65601



- Hardened cutting wheel.
- Tapered burr remover.
- Cuts copper, brass, aluminum & mild steel tubing 1/8" to 1-1/8" (3-29mm) outside diameter.

60/17/18/2.1' 283g



Mini tubing cutter

65602



- 1/8" to 7/8" (3-22mm) O.D. range.
- Small size allows use in restricted areas.

100/13.5/14.5/2.2' 135g



Professional tubing cutter

65604



- Solid and durable
- Aluminum alloy body
- High grade SUJ2 steel blade
- With deburring reamer.
- Capacity: 4-28mm (1/8"~1-1/8")
- For copper, brass and aluminum tubing.

60/16.8/17.8/1.8' 280g

Telescopic tubing cutter

65608



- For 1/8"-1 1/4"(3-32mm) O.D. tube,sk-2(1+1)

60/17.0/18.0/2' 270g

Ratchet tube cutter

656



Part no.	Capacity	packing	g
	mm		
65631	8-28	36/16.5/17.5/2.14	392
65632	28-67	12/13/13.5/0.84	1036

- Quick and easy ratchet mechanism make it easy and comfortable to use even in narrow spaces.
- 65631 can cut copper pipe up to 1.5mm.
- 65632 can cut stainless pipe up to 3mm.

Exhaust pipe and tubing cutter

65603



- Cuts thin walled steel and copper tubing from Ø20mm to Ø75mm (3/4"-3").
- Cuts quickly and easily.
- Fitted with 7 cutting blades for fast, clean cutting.



30/17.6/18.6/1.1' 586g

Inside/ Outside deburring tool

65304



- 3/16"-1 1/2"O.D, plastic body



120/5.0/6.0/2.5' 35g

Steel wire rope cutter

6927310



- For cutting steel wire rope up to 7mm and mild steel rod up to 5mm.
- For cutting copper and aluminum cable up to 60 mm².
- Length:310 mm.

Steel wire rope cutter

6927600



- For cutting steel wire rope up to 14 mm and mild steel rod up to 9 mm.
- For cutting copper and aluminum cable up to 150 mm².
- Length:600 mm.

Bolt cutter

9U0501



Part no.	packing	<i>l</i> Length	g
	9U050112	20/16.6/17.6/2.1'	300"12
9U050114	20/24.0/25.0/1.9'	355-14"	1200
9U050118	15/24.2/25.2/2.3'	455-18"	1613
9U050124	8/19.0/20.0/2.7'	610-24"	2375
9U050130	6/23.8/24.8/2.1'	762-30"	3967
9U050136	5/30.4/31.4/1.8'	863-36"	6080
9U050142	3/28.0/29.0/2'	1066-42"	9330

Micrometer

5096P9



Part no.	Specification	Packing
5096P9025	0-25mm	50/15/16/0.6'
5096P9050	25-50mm	50/25/26/0.8'
5096P9075	50-75mm	30/24/25/1.2'
5096P9100	75-100mm	25/20/21/1'

5096P9050~5096P9100

Multi-function magnetic pick-up

617



- Magnetic pick-up tool in telescopic extended, maximum 63cm extension.
- Take off the cap of bottom, the needle point head can be used for marking when draw a line or clean the narrow slot and small hole.
- Attach a fully adjustable mirror for inspection.
- All-in-one handy tool with pocket clip.



100/8.9/9.9/1.1' 235mm 89g

Multi-function inspection tool

617A



- 1pc Aluminum interchangeable handle
- 1pc Inspection mirror
- 1pc 6-lbs Magnetic retriever
- 1pc 10" Flexible adapter
- 1pc 9" 135 degree bended adapter
- 1pc 8" Straight adapter
- 1pc UV light
- 1pc LED light



40/19.2/20.2/0.8' 480g

3-in-1 Magnetic flexible pickup tool with light & mirror

617L



- Positive action turn on / off switch
- Magnetic pick-up 3.5lbs. (1.6kgw)
- Flexible shank of dia. 8.5mm and length 455mm(17-7/8")
- Oval glass mirror 25 x 50mm (1-1/8"x2")
- Replaceable bulb (2.2V, 0.25A)
- Inspection light is operated with 2pc AA batteries (not included)

72/15.1/16.1/2' 210g

Hinged flexible inspection mirror

61703



- Mirror: 50X70mm
- Length: 510mm

36/11.0/12.0/2.3' 300g

Palm flash light

68609



- Designed for grab the tools to light up the narrow or hard-to reach space
- It is magnetic on the back.



150/2.4/3.4/0.4' 16g

Infrared thermometer

9U0401



- Laser indicator.
- Changeable between:°C and °F
- Temperature range:-20 to 500°C
- Operating temperature:0 to 50°C
- Storage temperature:-20 to 50°C
- Precision:±2.5%or 3°C
- Distance-to-Spot: 10:1
- Power supply:9V battery

20/3.5/4.5/2' 175g

14 LED Work light with magnifying head

68610



- LED white light bulb.
- 3x magnifying glass.
- Magnifying glass's diameter is 4".
- Could be supplied power by the two kinds of options which are the 2 pcs of AAA battery or AC transformer
- Magnetic base attaches firmly to any metal surface.
- Power: AAA battery x 2 (1.5V/pc). Transformer (Input : AC100V / AC240V ; Output : DC4.5V).



20/18.5/20.0/2.7' Δ 925g

LED white light, clip-type (360° rotation)

68601



- 3 LEDES.



120/7.3/8.3/1.9' Δ 61g

Limber magnetic LED light

68602



- 3 LEDES.

120/10.2/11.7/3.5' Δ 85g



Magnetic LED head light

68603



- 11 LEDES.



100/12.7/13.7/3.55' Δ 127g

10W LED working light

68608



- Size: 330 x 95 x 100 mm
- Charging time: 3.5~4 hours
- Input power: AC 100~240V, DC 12V~24V
- Battery: 3.6V 2250mAh NI-MH
- Working time: 4 hours when fully charged
- Activetime: 2.5 hours



20/12.0/13.0/1.6' Δ 490g

Ultra COB LED slim light (lumen-adjustable switch)

68611

NEW

- Specifications:
 - A. LED Max power: 15W LED COB light
 - B. Li-ion Rechargeable battery: 3.7V 2200mAh
 - C. Charger input: AC100~240V 50/60Hz
 - D. Power output: 5.0V 1000mAh
 - E. Charger time: 3.5~4.0 hours
 - F. Avtive time: 2.5 hours
 - G. Storage temperature: -20°C to 70°C
 - H. Operation temperature: -5°C to 50°C
 - I. Product size: 375(L)x40(W)x30(H) mm



- Features:
 1. Micro adjustment lumen switch
 2. Foldable base with powerful magnet
 3. Swivel hanging hook
 4. Built-in 2200 mAh LI-ion battery
 5. For full light-approx 2.5 hours working hours, for semi light-approx 10 working hours
 6. 4 hours charging time:
 - in charging -red indicator flash,
 - charged completed-blue indicator light on,
 - low battery -yellow indicator flash
 7. Comes with 5V 1A USB charger & USB cable



20/6.5/7.5/1.2' Δ 325g

5W COB LED pen light

68612

NEW



- Size: 165x25x30 mm
- 5W LED COB light
- 360 degree of rotation
- Clip with magnet

100/8/9/1.4' 82g

Flash Light

68607



- 6 LEDS
- Battery: AAA x 3pc
- Size: 36*28*95 mm

30/6.6/7.6/0.4' 220g

EZ-release magnetic pick-up

88011



- 680mmL(26-3/4")
- Capacity: 8 LBS (3.63 kg)

Functions:

- EZ- Release magnetic pick up tool has a magnetic device that is able to attract any metallic items or spare parts laying on the floor without having to go through the trouble and pick them up one by one.



12/8.0/9.0/2.1' 660g

Midi EZ-release magnetic pick-up

88012



- 110x110x190mm
- Capacity: 10 LBS (4.54 kg)

Functions:

- Easy pick-up and release of metallic materials.
- Just squeeze the handle to quickly release material.



24/15.1/16.6/2.5' 630g

Power EZ-release magnetic pick-up

88013



- 400mmL(15-3/4")
- Capacity: 14 LBS (6.36 kg)



Functions:

- Quickly and safely clean up iron, steel chips and waste. Used for safe handling of sharp off cuts, separating small parts and steel scrap for nonferrous surfaces.

20/12.8/13.8/2.9' 640g

Heavy-duty flexible magnet pick-up tool

61701



- Flexible shank diameter 8.5mm; 440mmL
- With plastic PVC grip
- Magnetic Capacity: 3.5Lbs(1.6Kgw)
- Overall length: 535mm(21")

100/19/20/1.9' 190g

Flexible magnet pick-up tool

61702



- Flexible shank diameter 5.0mm; 400mmL
- With plastic PP grip
- Magnetic Capacity: 1.5Lbs(0.7Kgw)
- Overall length: 510mm(20")

72/11/12/1.8' 150g

Telescopic magnetic pick-up tool

88902



- 7-section extension rod.
- Length: 135 mm - 65 mm.
- Magnetic capacity: 3.5LBS (1.6kg).
- With pocket clip.

200/12.0/13.0/1.2' 60g

Demagnetizer / Magnetizer

88601



• Size: 5cmx5cmx3cm

120/16.6/17.6/1.3' 140g

3-Claw pick-up tool

88901



• Length:560mmL

150/15.1/16.1/1.2' 100g

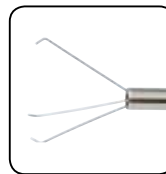

Magnetic fender cover with 4 pockets

88801



- Size:110cmx56cm
- Front cover made with PVC Sponge leather, backing is TR/BRUSH which does not damage or scratch any surface
- Top row includes STRONG magnets, which attract and stay on any metal surface easily.
- Easy to open and fold into compact size.
- The magnets are removable and replaceable before and after washing the fender cover.



17/16.7/17.7/4' 980g

Magnetic fender cover w/o pockets

88802



- Size:110cmx56cm
- Front cover made with PVC Sponge leather, backing is TR/BRUSH which does not damage or scratch any surface
- Top row includes STRONG magnets, which attract and stay on any metal surface easily.
- Easy to open and fold into compact size.
- The magnets are removable and replaceable before and after washing the fender cover.



18/13.2/14.2/4' 734g

Magnetic fender cover w/o pockets

88803

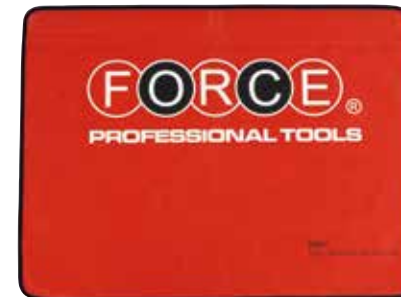

- Size:80cmx60cm
- Front cover made with PVC Sponge leather, backing is TR/BRUSH which does not damage or scratch any surface
- Top row includes STRONG magnets, which attract and stay on any metal surface easily.
- Easy to open and fold into compact size.
- The magnets are removable and replaceable before and after washing the fender cover.

18/10.2/11.2/4' 566g

Magnetic fender cover w/o pockets

88804



- Size:108cmx39cm
- Front cover made with PVC Sponge leather, backing is TR/BRUSH which does not damage or scratch any surface
- Top row includes STRONG magnets, which attract and stay on any metal surface easily.
- Easy to open and fold into compact size.
- The magnets are removable and replaceable before and after washing the fender cover.



18/11.9/12.9/4' 660g

Seat cover

G81



• Size:140mmx70mm

50/17.3/18.3/1.5' 350g

Steel creeper

9U0311

- Six wheels make the movements easily.
- The pillow is removable and replaceable.
- Size: 93×50×12 cm



1/8.0/9.0/1.8'

8kg

Steel car seat

9U0312

- Size: 40 × 30 × 30 mm
- Tools not included.



1/7.5/8.5/1.4'

7.5kg

Steel car seat

9U0313

- Strong and stable frames.
- Plastic corner for protection



1/6/6.7/1.08'

6kg

Oil barrel pump

887P01

NEW



- Two-piece telescopic suction tube fits 15 to 55 gallon drums.
- Tube adjusts from 19-9/32" to 35" (490mm to 890mm)
- Dispenses approximately 350 c.c. per stroke.
- 2" and 1-1/2" NPT bung nuts are equipped.

10/22.3/23.3/1.9'

2230g

Oil bucket pump

887P02

NEW



- For transferring of transmission, differential and heavier oils.
- Fits 25-50 lb (5-gallon pail) original refinery and 12" I.D. (300mm) clamp-on-carry bucket.
- Dispenses approximately 2 oz.(59 c.c.) per stroke.
- 5 ft. Oil-resistant hose.

4/13/14/4'

3250g

Aluminum rotary pump

887P03

NEW

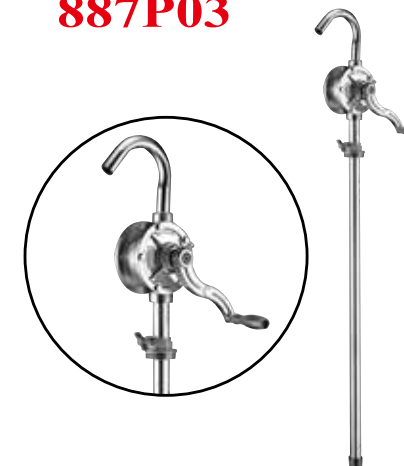

- 887P03 with aluminum alloy body, PPS rotor, PPS vane, FKM seal, spout and suction tube is plate.
- Application: gasoline, diesel fuel, kerosene, lubricant, ethyl alcohol.
- Capacity: 280 CC /rotation.

6/17.5/18.5/1.4'

2915g

Lever type grease gun

887120

NEW

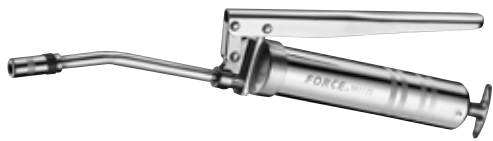

- Electroplated finish for long service life
- Short-stroke "lever action" for easy use
- Uses 120 c.c. bulk grease.

40/24.2/25.9/1.6' 605g

Air grease gun combination kit

887



- 1pc Air grease gun
- 1pc 1/4" Quick release coupler
- 1pc 1/4" Hose fitting
- 1pc Metallic bend spout
- 1pc 9" High pressure nylon hose
- 1pc Manual operated gun head

Features:

- 360°angle-free rotating & continuous flow.
- Where there is no air source or air hose can't reach, you can change the air gun head to the hand-operated gun head to proceed lubrication by manual operation.

Part no.	Size	<i>l</i> mm	 g	Packing
88701	14 o.z./400 c.c.	380	2600	8/18.2/21.1/2'
88701L	16 o.z./500 c.c.	380	2775	8/19.6/22.7/2'

Lever type grease gun

88702



- Electroplated finish for long service life
- Short-stroke "lever action" for easy use
- Uses 150 c.c. bulk grease.

20/20.9/22.9/1.9' 1150g

Lever type grease gun

88704 / 88704H9



88704

- Electroplated finish for long service life
- Short-stroke "lever action" for easy use
- Vented head cap for easy filling
- Use standard 14 oz. grease cartridge
- 3-ways loading: Standard 14 oz. cartridge, pressure filler and bulk 400 c.c.
- **88704H9** Greasegun-lever type(400c.c) with flexible hose 9"



88704H9

20/23.0/26.9/2.3' 1.3kg

Hand grease gun (400c.c.)

887400P

NEW



- Chrome-plated finish for long service life.
- Pistol grip "lever action" for easy use.
- Vented head cap & positive lock for easy filling.
- Knurled thick wall barrel for secure grip.
- Uses standard 14oz. grease cartridge.
- Working Pressure: 4300 P.S.I.
- 100mm straight pipe with standard coupler.
- Pistol type with 4-1/2" metal spout.

1330g

Oil suction gun (500 c.c.)

887A500



- Perfect for removing or replacing oil in engine/ transmissions/ differentials gearbox sumps/ crankcases, enables easy access to awkward locations.
- Ideal for vehicle & machinery use
- Knurled thick wall barrel for secure grip
- 10" Flexible hose
- Capacity Bulk:20 oz / 550 cc

20/17.0/18.0/1.4' 850g

Metal oil can (350ml)

887C01



- Angled spout enables lubricating in difficult-to-access locations.
- Robust pump provides trickle feed supply.
- Material of container:steel
- Material of pump:copper
- Volume of container:350 ml

48/15.4/16.4/4.4' 316g

Metal oil can with flexible spout (350 ml)

887C02



- Flexible spout enables lubricating in difficult-to-access locations.
- Robust pump provides trickle feed supply.
- Material of container:steel
- Material of pump:copper
- Material of flex spout:PVC
- Volume of container:350 ml



48/16.2/17.2/4.4' 316g

Plastic oil can with flexible spout (500 ml)

887C03

NEW



- Flexible spout enables lubricating in difficult-to-access locations.
- Robust pump provides trickle feed supply.
- Material of container:HDPE
- Material of pump:copper
- Material of flex spout:PVC
- Volume of container:500 ml

40/9.9/10.9/4.4' 220g

Flexible metal funnel

887D01

NEW



- Galvanized steel funnel with metallic flexible spout with mesh filter.
- For filling oil easily at inaccessible area.
- Tube length : 370 mm

10/3.4/4.4/2.6' 340g

3/8" DR. Pry bar head

68701



- This adapter gives you the versatility of a pry bar without the storage problems.
- Turn any 3/8"drive ratchet or breaker bar into a rolling pry bar head, then just disassemble them and toss it into your tool box when you're done.

72/7.4/18.4/0.65' 100g

Jumbo pry bar

687



Part no.	Length	g	packing
687780	780mm-30.7"	1085	20/20/21/0.8'
687910	910mm-36"	1830	12/22.0/23.0/0.5'
687910A	910mm-36"	1830	12/22.0/23.0/0.59'

Free long pry bar

68790 / 68755



- Auto repair tool.
- Machine repair tool.
- Space saving.
- Easy to carry and store.
- Any end part can be made available at your request.



Item no.	Slide Shank	Min. Length	Max. Length	Weight (kg)	Moment (kgf.m)	Packing
68790	16 mm Hex	65.5 cm 25.8"	90.5 cm 35.6"	2.0	50	8/16.0/16.8/1.6'
68755	13 mm Hex	42.0 cm 16.5"	55.5 cm 21.8"	0.9	35	20/18.0/19.0/0.94'

4pc Pry bar

904U5



- Size: 8"; 12"; 18"; 24"

12/17.0/18.0/1.5' 1420g

4pc Jumbo heavy duty pry bar set

904U2



- Extra large handles allow use of both hands for increased leverage
- Textured handle grips for secure hold
- Chrome Molybdenum steel shafts
- Hardened and tempered for maximum strength
- Heavy duty 5/8" bar stock
- Go-through shafts with steel end caps
- Sizes : 24" x 70°; 24" x 90°; 36" x 35°; 36" straight

2/17.5/18.5/1.4' 8730g

Pry bar

687

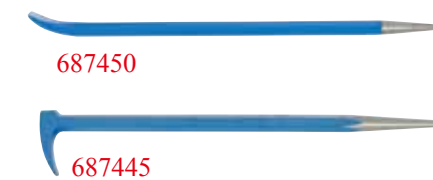

- Material: S45C

Part no.	Length	g	Packing
687450	450mm (17.72")	923	40/26.5/27.5/0.7'
687445	445mm (17-1/2")	846	20/17.6/18.6/0.7'

4pc Pry bar set

904U6



- 904U606 - 6";
- 904U612 - 12";
- 904U616 - 16";
- 904U620 - 20"

10/17/18/1.1' 1700g

Crowbar with crook beak

687400H



- Bending tool
- Length : 400mm (16")
- Bended head, hexagonal shank

40/18.6/19.6/0.47' 465g

Brush Assortment

938U1

NEW



- For professional cleaning and deburring of cylinders, tubes, bushings, etc.
- also for use on electric and air powered drills.
- Contents:
 - 12pc nylon brushes: Ø 8 - 9 - 10 - 11 - 12 - 13 - 14 - 15 - 16 - 17 - 18 - 19 mm
 - 12pc steel brushes: Ø 8 - 9 - 10 - 11 - 12 - 13 - 14 - 15 - 16 - 17 - 18 - 19 mm
 - 12pc brushes with brass coating: Ø 8 - 9 - 10 - 11 - 12 - 13 - 14 - 15 - 16 - 17 - 18 - 19 mm
 - 1pc 1/4" handle with adapter and quick lock
 - 1pc extension 150 mm

4/5.8/6.8/1'

1458g

Brass & nylon scrape brushes

9U3001

- Length : 75mm



240/8.7/9.7/2'

36g

Wire brush

9U3003

- Length : 220mm



120/7.7/8.7/2.5'

64g

13pc Extra long combination wrench set

51313



Part no.

755 8L...24L

Content...

13-Extra long combination wrench
8, 10, 11, 12, 13, 14, 15, 16, 17, 18,
19, 22, 24 mm

Extra long combination wrench

755...L



Part no.	Size	<i>l</i>		
	mm	mm	Packing	g
75506L	6	128	1000/20/21/0.61'	20
75507L	7	138	600/14.4/15.4/0.5'	24
75508L	8	148	400/12.8/13.8/0.7'	32
75509L	9	160	400/14/15/0.7'	35
75510L	10	167	400/16/17/0.7'	40
75511L	11	186	200/12/13/0.57'	60
75512L	12	196	200/16/17/0.59'	80
75513L	13	205	200/20/21/0.7'	100
75514L	14	223	200/24/25/0.62'	120
75515L	15	233	100/14/15/0.42'	140
75516L	16	243	150/24/25/0.67'	160
75517L	17	262	100/20/21/0.62'	200
75518L	18	272	100/22/23/0.62'	220
75519L	19	281	100/24/25/0.96'	240
75520L	20	301	50/14/15/0.63'	280
75521L	21	301	50/15/16/0.63'	300
75522L	22	319	50/16/17/0.82'	320
75523L	23	329	50/17 /18/0.82	340
75524L	24	339	40/18.8/19.8/0.77'	470
75525L	25	358	40/19.5/20.5/0.77'	488
75526L	26	358	40/21/22/0.77'	525
75527L	27	388	30/21/22/0.97'	700
75528L	28	388	30/21.5/22.5/0.97'	717
75529L	29	404	30/23/24/0.97'	767
75530L	30	404	30/24.6/25.6/0.97'	820
75531L	31	431	20/22/23/0.69'	1100
75532L	32	431	20/22/23/0.69'	1100
75533L	33	471	20/22/23/0.76'	1100
75534L	34	471	20/24/25/0.76'	1200
75535L	35	510	10/12.5/13.5/0.58'	1250
75536L	36	510	10/13/14/0.58'	1300



■ **908G5** P.1-26
Engine timing tool set for VW, Audi



■ **913G7** P.1-28
Engine timing tool set for VW / AUDI



■ **906G6** P.1-29
Engine timing tool set for VW



■ **908G18** P.1-30
Engine timing tool set for VW, AUDI, SKODA



■ **909G10** P.1-32
Engine timing tool set for VW, AUDI, SKODA, SEAT



■ **902G13** P.1-33
Camshaft central valve tool for VW / AUDI



■ **928G1** P.1-27
Engine timing tool set - VW, Audi, Seat and Skoda



■ **902G18** P.1-28
Camshaft clamp for VW / AUDI



■ **904G16** P.1-29
Engine timing tool set for VW / AUDI



■ **904G20** P.1-31
Engine timing tool set for VW, AUDI



■ **904G21** P.1-32
Timing chain test tool for VW, Audi, Seat, Skoda



■ **9G1210** P.1-33
Camshaft adjusting socket for AUDI



■ **929G1** P.1-27
Timing setting tool set - VW, Audi, Seat and Skoda



■ **904G15** P.1-28
Engine timing tool set for VW



■ **914G5** P.1-30
Engine timing tool set for VW / AUDI



■ **906G10** P.1-31
Engine timing tool for VW/Skoda/Seat



■ **904G17** P.1-32
3-in-1 Bosch timing tool for VW



■ **9G1216** P.1-34
Camshaft alignment tool



■ **910G5** P.1-27
Engine timing tool set for AUDI



■ **907G13** P.1-29
Engine timing tool set for VW / AUDI



■ **908G13** P.1-30
Engine timing tool set for VW



■ **910G9** P.1-31
Engine timing tool set for VAG 1.6 / 2.0TDI



■ **9G0129** P.1-33
Crankshaft seal installer tool for VW / AUDI



■ **903G14** P.1-34
Camshaft alignment tool





■ **9G1209** P.1-34
Camshaft alignment plate for VW, AUDI



■ **902G6** P.1-34
Camshaft alignment tool



■ **9G1206** P.1-35
Camshaft locking tool for VW



■ **903G10** P.1-35
Camshaft locking tool



■ **902G15** P.1-35
Engine timing tool set for VW / AUDI



■ **902G16** P.1-36
Engine timing tool set for VW / AUDI



■ **902G17** P.1-36
Engine timing tool set for VW / AUDI



■ **902G19** P.1-36
Engine timing tool set for AUDI



■ **9G0807** P.1-36
Engine timing tool for VAG



■ **9G1302** P.1-37
AUDI crank locking pin



■ **9G1303** P.1-37
VW/AUDI crank locking pin



■ **9G1305** P.1-37
Crank locking pin for AUDI



■ **9G1306** P.1-37
Crank locking pin for VAG



■ **906G4** P.1-38
Timing tool set for VAG 2.0 TDI PD



■ **9G1208** P.1-38
Crankshaft locking tool



■ **9G1301** P.1-38
Crankshaft locking tool for VW



■ **902G2** P.1-38
Locking tool set for VW, Audi



■ **9G0616** P.1-43
Counter hold tool for VW / AUDI



■ **9G0607** P.1-43
VW, AUDI belt pulley holder



■ **9G0608** P.1-43
VW, SEAT belt pulley holder



■ **903G15** P.1-52
Adjusting tensioner belt set



■ **903G8** P.1-52
Belt tension locking pins VW / AUDI / TDi PD engines



■ **902G4** P.1-53
Tensioner adjusting tool



■ **9G0704** P.1-45
Reaction wrench





■ **9G0705** P.1-45
Reaction wrench (1/2" DR.)



■ **34914010V** P.1-92
M10S Cylinder head bolt tool



■ **904T5** P.1-8
4pc VW, AUDI ignition coils puller set



■ **9G3103** P.1-8
Ignition coil puller for VAG



■ **9G0208** P.1-57
Hose clamp pliers (for VW, AUDI 2.0)



■ **62530** P.1-56
Hose clamp pliers



■ **61930** P.1-109
Assembly tool for plastic oil drain plug (VAG group)



■ **348...T** P.1-109
1/2" DR. Drain nut socket bit (M16H)



■ **61925** P.1-110
Oil filter drain tool (VW)



■ **912G6** P.1-78
VW, AUDI Diesel & gas injection remover tool (TDI & FSI)



■ **9G0721** P.1-117
Fuel tank locking ring tool for VW/AUDI



■ **9G0726** P.1-118
Fuel filter cover mounting tool for VW, Audi, Skoda and Seat



■ **9G0711** P.1-118
Fuel pump wrench



■ **902G25** P.1-50
Clutch centering disc



■ **907T6** P.3-29
Bush remover / installer for VW



■ **917T3** P.3-29
Wheel hub and wheel bearing extraction & installation set for VW-T5



■ **921T1** P.3-29
21pc Compact wheel hub/bearing kit , Ø 62mm, Ø 66mm, Ø 72mm

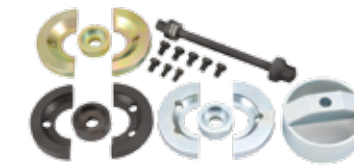

■ **9T0205** P.3-66
VW Automatic transmissions socket



■ **905T4** P.3-28
5pc VW, AUDI Rear suspension tool



■ **62821** P.3-44
Audi ball joint tool



■ **9T1481** P.3-50
Strut nut socket for VW/AUDI



■ **904T1** P.3-51
Drive nut set

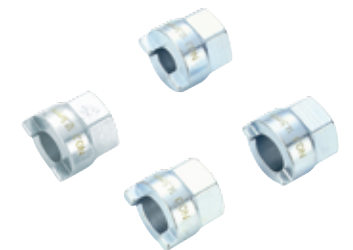

■ **914B1** P.3-9
Brake calliper guidance thread repair set



■ **905T11** P.3-67
VW Audi 7 Speed DSG clutch installer and remover



■ **9G4601** P.3-67
7-Speed DSG mechatronic unit remover for VW, AUDI, SEAT





■ **904G18** P.1-24

Engine timing tool set for BENZ M271



■ **9G1218** P.1-24

Engine timing tool set for BENZ



■ **906G7** P.1-26

Engine timing tool set for BENZ



■ **9G1215** P.1-25

BENZ flywheel locking tool



■ **915G6** P.1-25

Engine timing tool set for BENZ M133, M270, M274



■ **903G21** P.1-26

Engine timing tool set for BENZ M651



■ **904G19** P.1-26

Engine timing tool set for BENZ M156



■ **9G1219** P.1-42

Crankshaft pulley holder tool for BENZ M272/M273



■ **674** P.1-47

2pc M10 Alternator tools



■ **678** P.1-47

2pc T50 Alternator tools



■ **9G1803 / 9G1804** P.1-112

Transmission oil gauge



■ **9G1805 / 9G1806** P.1-112

Oil gauge



■ **903U2** P.1-116

3pc Benz fuel tank cap wrench

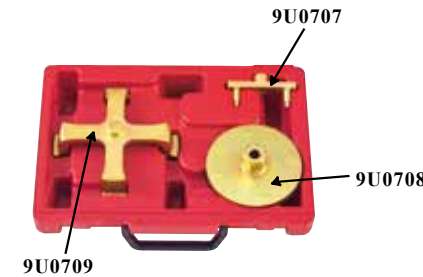

■ **9G0725** P.1-116

Fuel tank lid remover/installer for BENZ(W211/W203)/ BMW(E36/E46)



■ **9G0720** P.1-116

Fuel tank lid wrench for BENZ(W164/W166/W251)



■ **903G19** P.1-75

Diesel injector nozzle extractor set



■ **903G17** P.1-77

Injector nozzle extractor with spindle



■ **909G5** P.1-78

Injector extractor with slide hammer for DB CDI-engines

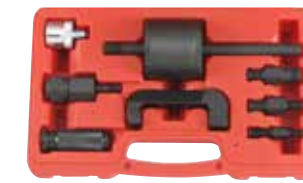

■ **9G0121** P.1-79

33 Teeth socket diesel injection pump for Mercedes



■ **9G0122** P.1-79

Diesel pre-chamber collar nut socket for Mercedes



■ **61935** P.1-105

Oil Filter Wrench for Mercedes Dodge Jeep



■ **62820** P.3-44

1/2" DR. BENZ (W163/W164) Pin wrench socket



■ **902B1** P.3-25

2pc Wheel stud alignment guide tool set



■ **902B2** P.3-26

2pc Wheel stud alignment guide tool set





908B3 P.3-26
8pc Wheel stud alignment guide tool set



9T0206 P.3-21
Wheel nut socket for Mercedes-Benz



905T3 P.3-49
Spring compressor for Mercedes



9T0304 P.3-51
BENZ W220 Shock absorber service tool set



9T0307 P.3-26
BENZ Bush remover / installer



9T0311 P.3-27
BENZ Axles wheel bearing extractor / installer



9T1401 P.3-51
BENZ (W203) Strut nut socket



9T1402 P.3-51
BENZ (W220) Strut nut socket



905T7 P.3-43
5pc 1/2"DR. Drive tooth socket for Mercedes



905T10 P.3-44
Ball-joint installer/ remover for BENZ (W220/W211/W230)



927T1 P.3-30
Professional wheel bearing tool set for BENZ



9T1407 P.4-1
BENZ Axle nut socket 95mm



9T1408 P.4-2
BENZ Rear axle nut socket 105-125 mm



9T1424 P.4-3
BENZ & MAN Clamp nut socket 56 mm



9T1425 P.4-3
BENZ & MAN Clamp nut socket 60 mm



9T1426 P.4-2
BENZ & MAN Rear axle nut socket 80-95 mm



9T1427 P.4-2
Benz & Man Rear axle nut socket 95-115 mm



6281842 P.4-3
3/4" DR. BENZ & MAN Pitman arm puller 42mm





■ **905G1** P.1-18
BMW (M52, M54, M56) Timing tool kit



■ **907G6** P.1-19
Timing tool kit (BMW MINI)



■ **913G6** P.1-19
Engine timing tool set for BMW M41, M51, M47, M57



■ **905G17** P.1-19
Engin timing tool set for BMW M47



■ **904G11** P.1-20
Diesel engine timing tool set for BMW N47/N47S



■ **908G9** P.1-20
Engine timing tool set for BMW N42, N46, N46T



■ **918G3** P.1-20
Engine timing tool set for BMW N42/N46



■ **906G5** P.1-21
Engine timing tool set for BMW N40/N45/N45T



■ **912G5** P.1-21
Engine timing tool set for BMW N51/N52/N53/N54



■ **905G19** P.1-21
Engine timing tool set for BMW N62 / N73



■ **912G12** P.1-22
Engine timing tool set for BMW M60, M62 (VANOS)



■ **906G8** P.1-22
Engine timing tool set for BMW N63



■ **908G15** P.1-22
Engine timing tool set for BMW N20

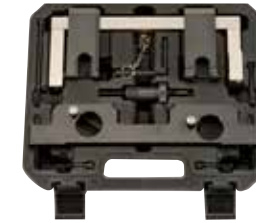

■ **908G16** P.1-23
Engine timing tool set for BMW N13/N18



■ **910G8** P.1-23
Petrol engine twin camshaft setting tool kit For BMW MINI / CITROEN / PEUGEOT

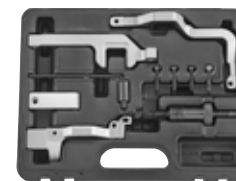

■ **905G12** P.1-23
Engine timing tool set for BMW, Mini,Citroen, Peugeot



■ **9G1220** P.1-41
Crankshaft harmonic balancer holder tool for BMW



■ **904G7** P.1-80
Diesel injection pump puller (BMW)



■ **9G1501** P.1-80
Diesel injection pump puller (BMW)



■ **674** P.1-47
2pc M10 Alternator tools



■ **9G0405** P.1-88
Valve pressure spring installer/remover for BMW N20, N55



■ **9G0406** P.1-88
Valve pressure spring installer/remover for BMW N51, N52



■ **54615012B** P.1-93
1/2" DR. 150mm Cylinder head bolt tool (E12)



■ **9G0717** P.1-113
Oil cooler line pliers





■ **9G0127** P.1-113
Fuel injector remover/installer tool for BMW N55



■ **9G0128** P.1-113
Fuel injector remover/installer tool for BMW N20/N55



■ **9G0130** P.1-114
Fuel injector remover/installer tool for BMW N63



■ **9G0725** P.1-116
Fuel tank lid remover/installer for BENZ (W 211/W 203) / BMW (E36/E46)



■ **9G0722** P.1-117
Fuel tank locking ring tool for BMW/MINI/PORSCHE



■ **9G0718** P.1-120
BMW line disconnect tool



■ **9G0719** P.1-120
BMW line disconnect tool



■ **908G11** P.1-76
Diesel injectors remover for BMW



■ **905G15** P.1-24
Fly wheel holder tool for BMW



■ **903T5** P.3-27
BENZ (W203) Strut nut socket



■ **902T2** P.3-66
Camber adjustment tool for BMW rear axles



■ **905G16** P.1-12
Engine timing tools set for VAUXHALL/ OPEL diesel 1.9 CDTI



■ **920G2** P.1-12
Engine timing Tool set for Opel / Vauxhall



■ **907G17** P.1-12
Engine timing tool set for Vauxhall/ Opel



■ **907G18** P.1-12
Engine timing tool set for Vauxhall/ Opel



■ **904G5** P.1-13
Timing tool kit (for GM 1.3 CDTI diesel engine)



■ **908G12** P.1-16
Diesel engine timing tool set for RENAULT, NISSAN, OPEL



■ **906G9** P.1-48
Puller, Harmonic damper pulley (Chrysler, GM)



■ **9G0802** P.1-51
Belt tensioning adjuster



■ **9G0803** P.1-51
Belt tensioning adjuster



■ **88442** P.1-70
10pc Deluxe noid lite / IAC test kit plus one fibre optic noid lite extension



■ **907G12** P.1-46
Power steering pump pulley kit



■ **63303** P.1-119
Diesel injection priming tool





■ **908T6** P.3-28
Rear suspension tool for GM VECTRA



■ **908T7** P.3-28
Rear axle bush installation/removal tool set for Vauxhall / Opel Vectra



■ **65014** P.3-10
1/2"DR. Pentagon socket 14mm



■ **905G8** P.1-15
Timing locking tools for FORD



■ **922G2** P.1-16
Engine timing tool set - Ford, Mazda



65019

■ **911G6** P.1-16
Engine timing tool set for FORD



■ **916G5** P.1-16
Engine timing tool set for FORD



■ **916G6** P.1-17
Engine timing tool set for Ford 1.0 EcoBoost

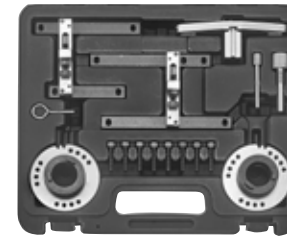

■ **905G22** P.1-17
Engine timing tool set for Ford 2.0 EcoBoost



■ **903G11** P.1-17
FORD flywheel locking tool



■ **9G1211** P.1-18
Camshaft setting bar & TDC timing pins (Ford / Mazda)



■ **904G6** P.1-18
FORD timing tool set



■ **907G12** P.1-46
Power steering pump pulley kit



■ **63302** P.1-119
Fuel transfer tool



■ **61927** P.1-103
Oil filter wrench -27mm



■ **905T5** P.3-27
Sub frame bush remover (Ford Mondeo)



■ **913T2** P.3-30
Wheel hub and wheel bearing extraction & installation set for Ford / Volvo / Mazda





■ **934G1** P.1-40
Engine timing tool set for FIAT



■ **907G16** P.1-40
Engine timing tool set for FIAT



■ **910G7** P.1-41
Engine timing tool set for Fiat 1.2 8V & 1.4 16V



■ **903G23** P.1-41
Engine timing tool set for FIAT



RENAULT
■ **917G1** P.1-13
Engine timing tool set - Renault

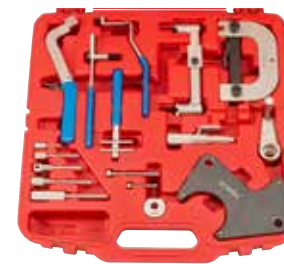

■ **905G20** P.1-14
Engine timing tool set for Renault



■ **908G12** P.1-14
Diesel engine timing tool set for RENAULT, NISSAN, OPEL



■ **911G5** P.1-13
Diesel engine locking tool set for Opel / Renault / Nissan



■ **902G5** P.1-14
Timing locking tools



■ **903G5** P.1-15
Renault timing kit (DCI engines)



■ **907G15** P.1-15
Engine timing tool set for RENAULT 1.8 / 2.0 16V



■ **9G0727** P.1-117
Fuel Filter Wrench 108mm



■ **65019** P.3-10
1/2"DR. Pentagon socket 14mm



65019

■ **920T2** P.3-30
Professional wheel bearing tool set For Peugeot / Citroen / Renault





935G1 P.1-29
Engine timing tool set - Peugeot, Citroen

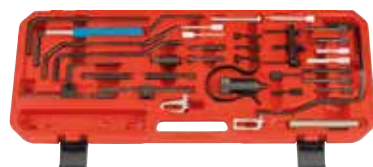

911G7 P.1-40
Engine timing tool set for CITROEN / PEUGEOT



9G0605 P.1-11
Flywheel holding tool



910G3 P.1-76
Diesel injector nozzle extractor set (PSA HDI engines)



904G13 P.1-74
4pcs Injection nozzle socket



9G0727 P.1-117
Fuel Filter Wrench 108mm



65019 P.3-10
1/2"DR. Pentagon socket 19mm



920T2 P.3-30
Professional wheel bearing tool set For Peugeot / Citroen / Renault



9T1482 P.3-45
Lower ball joint socket for Peugeot/ Citroen



Part No.	Page	Part No.	Page	Part No.	Page	Part No.	Page	Part No.	Page
10217-266	2-19	46611028	4-11	6113	4-20	61930	1-109	62521	3-54
10217A-266	2-19	48311021	8-9	614...	8-40	61933	1-109	62522	1-56
10217B-266	2-19	50223S-97	6-17	614A...	8-39	61935	1-105	62525	3-54
10217R-266	2-19	5023	8-12	614B225	8-39	620...	1-96	62526	3-55
121A...	8-4	5042	8-20	615...	8-40	62001	1-95	62527	3-55
174S...	8-4	5042S	8-20	616A...	8-29	62002	1-97	62528	1-57
20611	8-17	5051	1-107	616A400	8-30	62002	6-9	62529	5-15
20719	8-16	50510	8-31	616A700	8-30	62003	1-96	62530	1-56
2125P1	2-21	50513	5-21	616G...	8-30	62005	6-9	62531	3-56
2182N	2-19	5055P1...	8-38	617	8-53	62006	1-96	62601	5-4
2311	8-3	5061	1-108	61701	8-58	6202080	6-9	62602	5-4
3095	8-3	50612	3-1	61702	8-58	62101	1-84	62603	5-4
3126	6-16	50613	8-31	61703	8-54	62102	1-85	62604	5-4
3173N	2-16	5062	8-10	617A	8-53	62103	1-85	627...	3-47
3262	2-19	50622	8-11	617L	8-54	62104	1-85	62701	3-47
3313N	2-15	50623	8-11	61803	1-91	62105	1-85	627170	3-48
336...U	8-3	50634	8-11	619	1-98	62106	1-86	627200	3-48
34410508B	8-4	50635	5-11	61901	1-97	62107	1-86	627280	3-48
348...T	1-109	5066	8-11	61901A	1-97	62108	1-87	627280U	3-49
348100...	1-92	5066S	8-11	61902	1-98	62109	1-87	627320	3-48
34914010V	1-92	50713B	5-3	61903	1-99	62110	1-87	628...	3-42
4032	3-18	50719	5-3	61904	1-99	62110	6-9	62801	3-36
4032TH	3-18	50720	5-4	61904A	1-99	62112	1-88	62802	3-36
4033	3-19	50721	5-9	61905	4-27	62113	1-86	62803	3-37
4035	3-19	5078	8-20	61905...	1-101	62114	1-91	62804	3-37
4036	3-9	5096P9...	8-53	61906...	1-102	623...	1-97	62805	3-37
4037	3-19	5098LB	8-13	61908	1-101	62302	4-26	62806	3-37
4045	3-20	5122	1-108	61909	1-101	62501	5-14	6280723	3-39
4046	3-20	51313	8-70	61910	1-102	62502	5-14	6280728	3-39
4046A	3-20	5137XLS	8-13	61911	1-98	62503	5-14	6280817	3-39
4046B	3-20	51610	2-20	61912	1-101	62504	5-15	6280820	3-39
4059	8-3	5212	2-20	61913	1-100	62505	5-15	62809	3-39
40616	8-9	5363	2-20	61913	4-26	62506	5-15	62811	3-40
40912	3-52	539N...	2-16	61914	1-98	62507	5-16	62812	3-40
41161	2-19	54615012B	1-93	61915	1-104	62508	5-16	62813	3-40
4206	8-1	601235	8-10	61916	1-104	62509	5-16	62814	3-41
4263	8-1	601250	8-10	61917	1-104	62510	5-16	6281518	3-38
4265	8-2	602...C	8-31	61920	1-106	62511	5-17	6281522	3-38
4266	8-2	602...Q	8-32	61920A	1-105	62512	5-17	6281532	3-38
4285	8-1	606B200	8-30	61920B	1-106	62513	5-17	6281545	3-38
4341	2-20	608...	3-1	61923	1-110	62514	5-17	62817	3-41
443...	8-9	609...ABC	8-42	61925	1-110	62515	5-18	62818	3-42
44315022	1-123	609...ABO	8-42	61926	1-111	62516	5-18	6281830	3-42
445120...	3-18	609...ASC	8-42	61927	1-103	62518	1-56	6281830	4-18
466110...	4-6	609...ASO	8-43	61928	1-111	62519	3-53	6281832	3-42
466110...	8-9	6113	3-21	61929	1-111	62520	3-54	6281832	4-18

Part No.	Page	Part No.	Page	Part No.	Page	Part No.	Page	Part No.	Page
6281839	3-42	64707	7-1	65405...	8-37	65910...	7-33	66628	7-28
6281839	4-18	64709	7-7	65406...	8-37	65910Q...	7-33	666A...	7-23
6281842	4-3	64710	7-7	65407...	8-38	65911	7-29	666A01	7-25
6281847	4-19	64711	7-7	65408...	8-38	65912	7-29	666A02	7-25
6281858	4-11	64712	7-8	655...	8-16	65913	7-29	666A03	7-25
6281862	4-19	64713	7-8	656	8-47	659A...	7-31	666B	3-41
6281867	4-5	64714	7-8	656...	8-51	659C2...	7-31	666T...	7-20
62819	3-39	64715	7-8	65601	8-50	659C3...	7-31	66901	8-28
62820	3-44	6472160	7-7	65602	8-50	660...	5-9	66902	8-28
62821	3-44	6472195W	7-6	65603	8-51	660...D	5-9	66903	8-28
628E...	3-41	6473268N	2-16	65604	8-51	66101	5-10	67001	8-26
62901	3-11	647A...	7-6	65605	8-50	66201	5-10	672	8-29
62902	3-11	647B...	7-6	65607	8-39	664	3-34	674	1-47
63001	1-2	647C...	7-17	65608	8-51	66401	3-35	67402	1-47
63002	1-2	647H...	7-9	65641	8-48	66402	3-35	677...	3-16
63003	1-2	647H...	7-11	656A	8-46	66403	3-35	678	1-47
63004	1-2	647H...-72	7-9	656AM	8-46	66404	3-35	67801	8-34
63005	8-24	647H...-72	7-11	656B	8-47	66431	7-21	67802	8-34
63005B	8-24	647P...	7-17	656B01	8-48	66432	7-21	67803	5-22
63006	8-24	647P...	8-45	656BM	8-48	664A	3-34	678260	8-34
63006B	8-24	648...	8-15	656F	8-46	664P	7-20	678535	8-35
63007	1-123	648...L	8-15	656M	8-47	665B	5-1	678810	8-35
63008	1-7	6480607	8-15	65701	5-20	666...	7-19	678N260	8-35
631...	1-103	649...E	8-12	65714...	5-21	66601	7-17	678N320	8-36
631B02	1-105	649M...	2-18	658	3-13	66602	7-17	67901	5-11
63302	1-119	649N...	2-18	65802	3-14	66603	3-32	67902	5-11
63303	1-119	65001	3-10	65803	3-15	66610	7-18	67903	5-12
634...	5-28	65014	3-10	65804	3-15	66612	7-18	67904	5-12
634...A	5-29	65019	3-10	65805	3-14	66613	7-18	67905	5-12
639...	1-102	651...	7-16	65815	3-14	66614	7-19	67906	5-12
639230	1-102	65103	7-16	65816	3-10	666140	7-20	6801	2-12
639230	4-27	65104	7-16	65821	3-12	66616	7-23	68010	2-15
64101	1-3	65111L	7-15	65901...	7-31	66617	7-26	68011	2-14
647...	7-2	65112L	7-15	65902...	7-32	66617A	7-27	68012	2-15
647...	7-3	65113L	7-15	65903...	7-32	66618	7-24	68013	2-11
647...	7-4	65202	8-40	65903...	7-34	66618M	7-24	68015	2-13
647...P	1-1	65203	5-11	65906	7-29	66618MA	7-24	6802	2-12
647...P	7-1	653...	8-49	6590630	7-30	66619	7-23	6803	2-12
647...W	7-5	65303	8-49	65907...	7-30	66620	7-22	6804	2-13
64701L	7-1	65304	8-52	6590725...	7-30	66621	7-22	6805	2-13
64702L	7-1	65305	8-49	65908...	7-30	66622	7-26	68051	2-24
64703	7-13	65306	8-50	6590825	7-28	66623	7-26	68052	2-24
64703A	7-13	653180	8-49	6590850	7-28	66624	7-27	68053	2-25
64704	7-9	65401...	8-36	65909...	7-32	66625	7-27	68055	2-25
64705	7-9	65402...A	8-37	65909Q...	7-33	66626	7-27	68056	2-25
64707	3-18	65404...	8-36	65910	7-23	66627	7-28	68057	2-25

Part No.	Page	Part No.	Page	Part No.	Page	Part No.	Page	Part No.	Page
6805A	2-13	687...	8-67	8073...BM	1-5	88427	2-8	902G20	1-133
6806	2-14	687...	8-68	8073...M	1-7	88431	2-8	902G21	1-120
6807	2-12	68701	8-66	8073...MTH	1-7	88432	2-9	902G22	1-59
68071	2-26	687400H	8-68	8073...U	1-3	88433	2-9	902G23	1-112
68072	2-26	68755	8-67	8073...U	1-5	88435	2-6	902G25	1-50
6808	2-14	68790	8-67	8073...UM	1-4	88442	1-70	902G26	1-50
68081	2-26	688	3-65	8073...UM	1-5	88444	2-10	902G3	1-71
6809	2-14	68801	3-65	8073250...M	1-6	88502	3-7	902G4	1-53
681...	3-16	6926315	2-23	8074...	1-6	88503	3-8	902G5	1-14
681600	4-20	6926600	2-23	8074...M	1-7	88601	8-59	902G6	1-34
681A300	3-17	6926800	2-23	8074...U	1-4	887...	8-63	902G7	1-90
681B400	3-17	6926R255	2-23	8074...U	1-5	88702	8-63	902G8	1-74
681D515	3-17	6926R280	2-24	8074...UM	1-4	88704	4-28	902G9	1-53
6821	3-22	6926R400	2-24	8074...UM	1-6	88704	8-64	902K1	4-22
68301	5-6	6927310	8-52	8111L	8-14	88704H9	8-64	902K2	4-25
68302	5-6	6927600	8-52	818...	8-21	887120	8-63	902M1	5-24
68303	5-6	6957240	8-46	818A	6-14	887400P	8-64	902M3	5-24
68304	5-7	6958...	8-40	818A	8-21	887A500	8-65	902M5	5-8
68305	5-7	6959180	8-41	818B...	8-21	887C01	8-65	902T1	3-64
68306	5-7	698...	8-39	823...	6-14	887C02	8-65	902T2	3-66
68351	5-5	71817004A	8-16	823A...	6-14	887C03	8-66	902U1	5-24
68352	5-5	71F...	8-17	82603	5-20	887D01	8-66	902U2	8-13
68353	5-5	750...	3-22	827B02	8-5	887P01	8-62	902U3	3-24
68354	5-5	750...	6-16	827B03	8-4	887P02	8-62	902Y1	6-3
68355	5-6	751...A	8-12	829...	2-17	887P03	8-62	903B1	3-11
684...	8-45	755...L	8-70	829A...	2-17	88801	8-59	903C1	2-5
684...A	8-45	76808XL	8-14	830...	2-18	88802	8-59	903G1	1-89
684C...	8-45	774...A	6-15	87901	8-38	88803	8-60	903G10	1-35
68509...	7-10	774...B	6-15	88011	8-57	88804	8-60	903G11	1-17
68514...	7-11	7743200N	2-17	88012	8-57	88901	8-59	903G12	1-61
68520...	7-13	802320N	2-17	88013	8-58	88902	8-58	903G13	1-124
685A09...	7-10	804...F	8-14	881...	8-10	890220	1-107	903G14	1-34
685A14...	7-12	8043N...	2-16	88201	5-20	891A01	8-18	903G15	1-52
685A20...	7-13	8044080L	8-14	88401	2-21	891B01	8-17	903G16	1-82
685B09...	7-10	80525...	8-5	88402	2-21	902B1	3-25	903G17	1-77
685C14...	7-12	8052565...	8-5	88403	2-21	902B2	3-26	903G18	1-61
685D14...	7-12	80535...	8-6	88404	2-22	902C1	2-11	903G19	1-75
68601	8-55	8053585...	8-6	88407	2-22	902G10	1-133	903G2	1-115
68602	8-55	80536...	8-7	88408	2-22	902G11	1-66	903G20	1-54
68603	8-56	80545...	8-7	88409	1-9	902G13	1-33	903G21	1-26
68607	8-57	80545108...	8-8	88421	2-6	902G15	1-35	903G22	1-39
68608	8-56	80546...	8-8	88422	2-6	902G16	1-36	903G23	1-41
68609	8-54	8073...	1-6	88423	2-7	902G17	1-36	903G5	1-15
68610	8-55	8073...B	1-3	88424	2-7	902G18	1-28	903G8	1-52
68611	8-56	8073...B	1-4	88425	2-7	902G19	1-36	903M1	1-94
68612	8-57	8073...BM	1-3	88426	2-8	902G2	1-38	903T1	3-56

Part No.	Page	Part No.	Page	Part No.	Page	Part No.	Page	Part No.	Page
903T2	3-38	904U5	8-67	906T3	3-40	908T1	3-34	911G6	1-16
903T2	4-20	904U6	8-68	906T4	3-43	908T1	4-22	911G7	1-40
903T3	3-65	905G1	1-18	906T5	3-21	908T5	3-49	911G8	1-130
903T5	3-27	905G10	1-63	906T6	3-36	908T6	3-28	911G9	1-9
903T6	1-50	905G12	1-23	906T7	3-7	908T7	3-28	911M1	5-3
903U1	8-43	905G13	4-24	906U1	8-32	908T8	3-50	911T1	3-23
903U2	1-116	905G15	1-24	906U2	8-22	908T9	3-67	912...	8-26
903Y1	6-4	905G16	1-12	907B1	3-12	908U2	8-25	912C1	2-1
904B1	3-4	905G17	1-19	907G10	1-121	909G1	1-68	912G1	1-69
904B2	3-47	905G18	1-47	907G12	1-46	909G10	1-32	912G10	1-41
904G10	1-121	905G19	1-21	907G13	1-29	909G2	1-48	912G11	1-133
904G11	1-20	905G20	1-14	907G15	1-15	909G3	1-55	912G12	1-22
904G12	1-121	905G22	1-17	907G16	1-40	909G5	1-78	912G2	1-72
904G13	1-74	905G4	1-46	907G17	1-12	909G6	1-81	912G3	1-119
904G15	1-28	905G6	1-125	907G18	1-12	909G7	1-68	912G5	1-21
904G16	1-29	905G8	1-15	907G2	1-122	909G8	1-77	912G6	1-78
904G17	1-32	905K1	4-19	907G3	1-45	909G9	1-55	912G8	1-74
904G18	1-24	905M1	5-23	907G5	1-123	909K1	4-21	912G9	1-9
904G19	1-26	905M3	1-93	907G6	1-19	909M1	5-2	912T2	3-46
904G20	1-31	905M4	5-2	907G7	1-84	909T2	3-43	912T3	3-44
904G21	1-32	905M5	5-30	907G7	4-24	909T3	4-17	912T5	3-36
904G3	1-75	905M7	5-8	907G8	1-64	909T5	3-53	912T6	3-13
904G3	4-23	905T1	3-45	907M1	5-26	909T6	3-12	912U1	8-44
904G4	1-71	905T10	3-44	907T1	1-126	909U1	8-25	912U3	8-22
904G5	1-13	905T11	3-67	907T3	3-15	909Y1	6-1	9130U1	8-25
904G6	1-18	905T2	3-42	907T5	3-68	909Y2	6-12	913C1	2-11
904G7	1-80	905T3	3-49	907T6	3-29	910...	8-26	913G1	1-72
904G8	1-60	905T4	3-28	907U1	1-126	910C1	2-1	913G3	1-10
904G9	1-78	905T5	3-27	907U2	8-28	910C3	2-2	913G6	1-19
904K1	4-23	905T6	7-21	907U5	3-21	910G3	1-76	913G7	1-28
904M1	5-22	905T7	3-43	908B2	3-5	910G5	1-27	913M2	5-2
904M2	5-2	905T8	3-38	908B3	3-26	910G7	1-41	913T1	1-51
904M3	5-23	905T9	3-9	908G1	1-68	910G8	1-23	913T2	3-30
904M4	1-94	905U1	8-24	908G11	1-76	910G9	1-31	913U1	8-33
904M5	5-26	906G1	1-83	908G12	1-14	910M1	5-1	913U2	8-33
904M6	5-22	906G10	1-31	908G13	1-30	910M3	5-27	913Y1	6-6
904M7	5-21	906G2	1-63	908G15	1-22	910M5	5-13	914B1	3-9
904T1	3-51	906G3	1-67	908G16	1-23	910T1	7-22	914B2	3-8
904T2	1-126	906G4	1-38	908G17	1-39	910U1	8-23	914G1	1-64
904T4	3-25	906G5	1-21	908G18	1-30	910U2	8-22	914G3	1-72
904T5	1-8	906G6	1-29	908G2	1-64	910U3	8-44	914G5	1-30
904T8	3-53	906G7	1-25	908G5	1-26	910Y1	6-5	915G1	1-42
904U1	1-93	906G8	1-22	908G6	1-52	911G1	1-42	915G2	1-108
904U2	8-68	906G9	1-48	908G7	1-86	911G2	1-89	915G3	1-90
904U3	8-43	906M2	5-1	908G8	1-67	911G3	1-95	915G5	1-69
904U4	1-125	906T2	8-47	908G9	1-20	911G5	1-13	915G6	1-25

Part No.	Page	Part No.	Page	Part No.	Page	Part No.	Page	Part No.	Page
915M1	5-8	927T1	3-30	9B1801	3-5	9G0608	1-43	9G1206	1-35
915U1	8-27	928G1	1-27	9B1802	3-5	9G0609	1-55	9G1208	1-38
915U2	3-33	929...	8-26	9B1803	3-6	9G0610	1-93	9G1209	1-34
915U3	8-32	929G1	1-27	9B3501	3-7	9G0612	1-127	9G1210	1-33
915U4	8-33	929G2	1-49	9C2001	2-3	9G0613	1-127	9G1211	1-18
916G2	1-73	933G1	1-83	9C2002	2-3	9G0615	1-128	9G1215	1-25
916G2	4-25	933M1	5-29	9C2005	2-4	9G0616	1-43	9G1216	1-34
916G3	1-82	933T1	3-31	9C2008	2-4	9G0617	1-43	9G1218	1-24
916G5	1-16	934G1	1-40	9C2009	2-5	9G0704	1-45	9G1219	1-42
916G6	1-17	935G1	1-39	9G0101	1-8	9G0705	1-45	9G1220	1-41
917G1	1-13	937G1	1-73	9G0102	1-89	9G0706	1-115	9G1301	1-38
917T1	3-33	938G1	1-73	9G0103	1-90	9G0708	1-44	9G1302	1-37
917T2	1-49	938U1	8-69	9G0104	1-58	9G0709	1-44	9G1303	1-37
917T3	3-29	939T1	3-52	9G0105	1-59	9G0710	1-61	9G1305	1-37
918C1	2-2	940G1	1-70	9G0106	1-59	9G0710A	1-62	9G1306	1-37
918G3	1-20	943U1	8-27	9G0109	1-58	9G0711	1-118	9G1401	1-122
919C1	2-9	944M1	5-25	9G0110	1-59	9G0712	1-44	9G1403	1-122
919G2	1-71	945G1	1-48	9G0111	1-60	9G0713	1-115	9G1501	1-80
919G2	6-6	946G1	1-70	9G0112	1-60	9G0715	1-114	9G1511	1-128
919G3	1-65	949T1	3-32	9G0113	1-125	9G0716	1-114	9G1801	1-91
919T1	3-64	950T1	3-32	9G0114	1-75	9G0717	1-113	9G1801A	1-91
920C1	2-2	956G1	1-2	9G0114	4-24	9G0718	1-120	9G1802	1-92
920G1	1-124	958G1	1-131	9G0115	1-60	9G0719	1-120	9G1802A	1-92
920G2	1-12	964G1	1-110	9G0117	1-58	9G0720	1-116	9G1803	1-112
920T1	3-31	990C1	2-10	9G0118	1-80	9G0721	1-117	9G1804	1-112
920T2	3-30	9B0101	3-1	9G0119	1-77	9G0722	1-117	9G1805	1-112
920U1	8-26	9B0102	3-2	9G0120	1-58	9G0723	1-118	9G1806	1-112
920U2	8-44	9B0104	3-2	9G0121	1-79	9G0725	1-116	9G2201	1-66
920U3	8-23	9B0105	3-2	9G0122	1-79	9G0726	1-118	9G2202	1-67
921G1	1-48	9B0107	3-3	9G0123	1-79	9G0727	1-117	9G2203	1-65
921G2	1-84	9B0108	3-3	9G0125	4-23	9G0802	1-51	9G2204	1-66
921T1	3-29	9B0109	3-3	9G0126	1-57	9G0803	1-51	9G2401	1-11
922G1	1-65	9B0301	3-23	9G0127	1-113	9G0804	1-54	9G3101	1-8
922G2	1-16	9B0302	3-23	9G0128	1-113	9G0807	1-36	9G3102	1-8
922G3	1-46	9B0304	3-2	9G0129	1-33	9G0808	1-54	9G3103	1-8
922G5	1-49	9B0401	3-11	9G0130	1-114	9G0809	1-53	9G4001	1-63
922G6	1-69	9B0402	3-10	9G0201	1-57	9G0901	1-94	9G4005	2-5
923C1	2-1	9B0701	1-99	9G0208	1-57	9G0902	1-95	9G4101	1-129
924...	8-26	9B0701	6-10	9G0301	1-123	9G0903	1-94	9G4102	1-129
924B2	3-8	9B0702	1-99	9G0302	2-3	9G1001	1-81	9G4106	1-129
924T1	3-31	9B0703	1-100	9G0303	1-62	9G1002	1-81	9G4107	1-130
925U1	8-23	9B0703A	1-100	9G0405	1-88	9G1201	1-10	9G4108	1-130
926G1	1-76	9B0703B	1-100	9G0406	1-88	9G1202	1-10	9G4111	1-131
927B1	3-13	9B0704	1-100	9G0605	1-11	9G1203	1-10	9G4121	1-131
927G1	1-124	9B0704	4-26	9G0606	1-42	9G1204	1-11	9G4122	1-132
927G3	1-83	9B1701	3-4	9G0607	1-43	9G1205	1-11	9G4123	1-132

Part No.	Page	Part No.	Page	Part No.	Page	Part No.	Page	Part No.	Page
9G4125	1-132	9T0302	3-22	9T1428	4-12	9T3711	4-27	9Y0141	6-7
9G4301	1-121	9T0304	3-51	9T1429	4-5	9U0101	5-13	9Y0142	6-8
9G4601	3-67	9T0307	3-26	9T1430	4-8	9U0102	6-14	9Y0143	6-8
9K0101	4-12	9T0311	3-27	9T1431	4-8	9U0102	8-43	9Y0143B	6-8
9K0102	4-13	9T0316	3-64	9T1432	4-8	9U0201	8-18	9Y0145	6-13
9K0103	4-13	9T0317	3-66	9T1433	4-9	9U0201A	8-18	9Y0146	6-5
9M0101	5-23	9T0401	3-23	9T1435...	4-9	9U0202	8-19	9Y0151	6-11
9M0102	5-24	9T0401D	3-24	9T1436	4-10	9U0203	8-19	9Y0161	6-13
9M0105	5-13	9T0402	3-24	9T1437	4-10	9U0204	8-19	9Y0181	6-3
9M0106	5-14	9T0403	3-24	9T1438	4-11	9U0205	8-19	9Y0182	6-1
9M0107	5-8	9T0405	4-21	9T1439	4-12	9U0206	8-19	9Y0183	6-1
9M0108	5-31	9T0405B	4-21	9T1440	4-13	9U0221	8-19	9Y0185	6-2
9M0201	5-31	9T0407	3-25	9T1441	4-14	9U0301	3-33	9Y0186	6-2
9M0202	5-31	9T0501	3-55	9T1442	4-14	9U0311	8-61	9Y0187	6-3
9M0203	5-23	9T0502	3-56	9T1443	4-14	9U0312	8-61	9Y0188	6-2
9M0207	5-30	9T0503	3-57	9T1445	4-15	9U0313	8-61	9Y0201	6-12
9M0301	5-10	9T0505	3-57	9T1446	4-15	9U0401	8-54	9Y0202	6-12
9M0302	5-10	9T0701	3-45	9T1447	4-15	9U0501...	8-52	9Y0203	6-13
9M0303	5-10	9T0801	3-46	9T1448	4-16	9U0701	6-13	9Y0301	6-10
9M0503	5-27	9T1401	3-51	9T1449	4-16	9U0701	8-13	9Y0302	6-10
9M0505	5-27	9T1402	3-51	9T1450	3-68	9U0702	1-62	9Y0303	6-10
9M1501	5-7	9T1403	6-12	9T1481	3-50	9U0706	1-106	9Y0305	6-11
9M1601	5-18	9T1404	3-42	9T1482	3-45	9U0710	1-107	9Y0306	6-11
9M1602	5-18	9T1405	4-1	9T3403	3-50	9U0711	1-107	G81	8-60
9M1603	5-19	9T1406	4-1	9T3606	3-60	9U0901	8-33	K3021	1-1
9M1604	5-19	9T1407	4-1	9T3606M	3-61	9U0902	8-33	K64706	7-14
9M1605	5-19	9T1408	4-2	9T3606P	3-61	9U1001	8-29	K64706S	7-14
9M1606	5-19	9T1409	4-4	9T3607	3-61	9U1101	8-28	K64708	7-14
9M1607	5-20	9T1410	4-4	9T3608	3-62	9U1102	8-28	K909G4	1-82
9M2301	5-29	9T1411	4-4	9T3609	3-59	9U2101	5-28	K909G4	4-25
9M2904	5-28	9T1412	4-5	9T3610	3-60	9U3001	8-69	K913G5	1-1
9M3401	5-30	9T1413	4-16	9T3610	4-28	9U3002	2-4	K913M1	5-25
9T0101	8-41	9T1414	4-17	9T3611	3-60	9U3003	8-69	T31010	1-1
9T0103	8-41	9T1415	4-17	9T3611	4-28	9U39...	3-69	T50918	8-12
9T0104	8-41	9T1416	4-7	9T3612	3-62	9U39...	4-22	T905M2	5-21
9T0105	8-42	9T1417	4-6	9T3621	3-58	9U3921	3-69		
9T0106	3-6	9T1418	4-7	9T3622	3-58	9U4501	8-20		
9T0107	3-6	9T1419	4-7	9T3623	3-58	9Y0101	6-4		
9T0201	3-57	9T1420	4-6	9T3624	3-59	9Y0111	6-4		
9T0202	3-4	9T1421	4-10	9T3625	3-59	9Y0121	6-4		
9T0203	3-4	9T1422	4-9	9T3701	3-62	9Y0122	6-5		
9T0204	3-46	9T1423	4-10	9T3706	3-63	9Y0123	6-5		
9T0204B	3-46	9T1424	4-3	9T3707	3-63	9Y0131	6-7		
9T0205	3-66	9T1425	4-3	9T3708	3-63	9Y0132	6-7		
9T0206	3-21	9T1426	4-2	9T3709	3-63	9Y0133	6-7		
9T0301	3-64	9T1427	4-2	9T3710	3-63	9Y0135	6-6		



Tool Storage V5.2

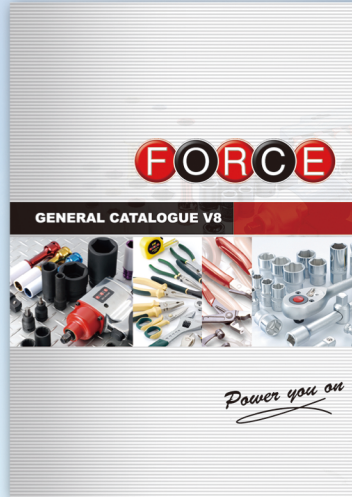

General Catalogue V8

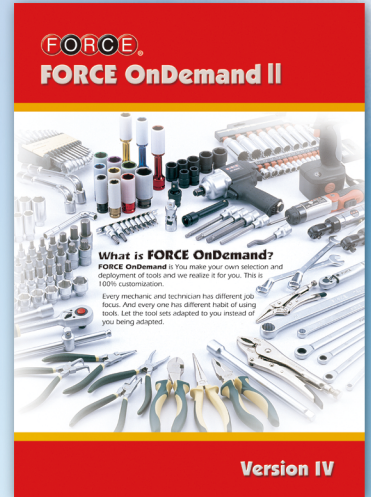

FORCE OnDemand IV





FORCE[®]

Shyang Yun Tools Co., Ltd.
Shyang Yun Hardware Co., Ltd.

No.161, Sitou Rd., Shengang Dist., Taichung City 42953, Taiwan

Tel: +886-4-25631268 Fax: +886-4-25632678

<http://www.force.com.tw> E-mail: info@force.com.tw

